



Storey
Catalog

2024



Dear Friends,

One of the values that motivates all of us at Storey—both staff and authors—is the opportunity for transformation and growth. Whether the goal is helping support the cycles of our natural world, the expansion of knowledge and imagination, or healthy personal growth, Storey books offer insightful and creative guidance.

Starting at ground level, *The World of Rot* (page 18) invites kids to explore the slimy wonders of decay and transformation with a colorful, closeup look at the organisms that make life on our planet possible. In *The Tinkering Workshop* (page 17), they are challenged to transform a box of ordinary hardware-store supplies into one-of-a-kind inventions.

Craft-loving adults will find inspiration for transforming old postcards into fun, artsy messages with *The Vintage Postcard Collage Kit* (page 13). And with *Coloready Mushrooms* (page 9), paint-by-number undergoes an appealing transformation for the contemporary aesthetic.

Makers of all types will discover ways to transform their creativity into a tool for activism in *Let's Move the Needle* (page 8), a spirited guidebook from Shannon Downey, a leader in the craftivist movement. And fans of fermented foods will delight in *The Fermentation Oracle* (page 10), combining inventive kitchen recipes with insights for personal transformation.

Saving the biggest thought for last, Maria Popova's *The Universe in Verse* (page 2) offers a mind-expanding exploration of how scientific discovery and poetry align to transform our understanding and appreciation of the wonders of our world.

From the soil to the heavens, the opportunities for growth and transformation are all around us!

With warm wishes,

Deborah

Deborah Balmuth, Publisher



FRONTLIST 2

BACKLIST

Gardening	26	Horses	90	Home	116
Well-Being	37	Animals	95	Country Wisdom Bulletins	118
Nature	45	Pets	104	TITLE INDEX	122
Food & Drink	48	Farming & Sustainable Living	105	AUTHOR INDEX	126
Children	64	Building	111	ORDERING INFORMATION	Inside Back Cover
Crafts	76				



Front/Back Cover photos © Kim Dong.

Header: © Dong Kim, *The Garlic Companion*. Bottom clockwise from upper left: © Eric Tournieret, *Heart of the Hive*; © Ofra Amit, *Universe in Verse*; © Julie Bidwell Cooking Class; © Mars Vilaubi, *Let's Move the Needle*; © Bruno Valasse, *World of Rot*

The creator of *The Marginalian* celebrates the human search for truth and beauty

- Based on Popova's renowned performance event that attracts thousands of people from around the world. Participants in the event have included poets, musicians, artists, and scientists such as Yo Yo Ma, Krista Tippett, Robin Wall Kimmerer, and many others.
- Celebrates often overlooked scientists. Popova brings forward some of the unsung heroes of science in short, engaging essays.
- Maria Popova's blog, *The Marginalian*, is wildly popular, with 4.7 million Facebook followers and 364,000 Instagram followers (@mariapopova).

OCTOBER 2024

112 pages; 6 x 8; Full-color; illustrations throughout
Hardcover; \$22.00 US
 ISBN 978-1-63586-883-8

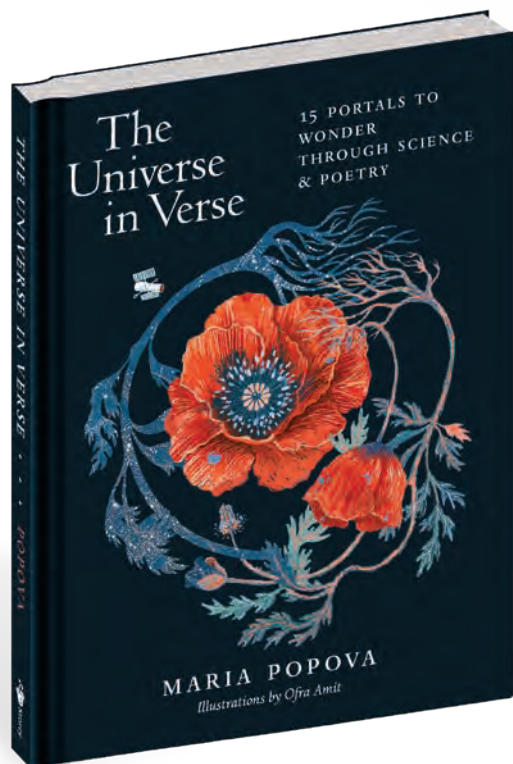

The Universe in Verse

Maria Popova

Maria Popova, the inimitable creator of *The Marginalian*, presents fifteen short, digestible essays on the wonders and mysteries of science and nature each accompanied by a curated poem on the same subject and illustrated by award winning artist Ofra Amit.

Poetry and science, as Popova writes in her introduction, "are instruments for knowing the world more intimately and loving it more deeply." In essays on subjects ranging from the mystery of dark matter and the infinity of pi to the resilience of trees and the intelligence of octopuses, Popova tells the stories of scientific searching and discovery. These stories are interwoven with details from the very real and human lives of scientists—many of them women, many underrecognized—and poets inspired by the same questions and the beauty they reveal. Each essay is paired with a poem reflecting its subject by poets ranging from Emily Dickinson and Edna St. Vincent Millay to Maya Angelou and Tracy K. Smith.

Maria Popova thinks and writes about our search for meaning through science and philosophy, poetry and children's books, and always through the lens of wonder. She is the creator of *The Marginalian*, born in 2006 under the outgrown name Brain Pickings, author of *Figuring* and *The Snail with the Right Heart*, and maker of *The Universe in Verse*—a charitable celebration of the wonder of reality through stories of science winged with poetry.

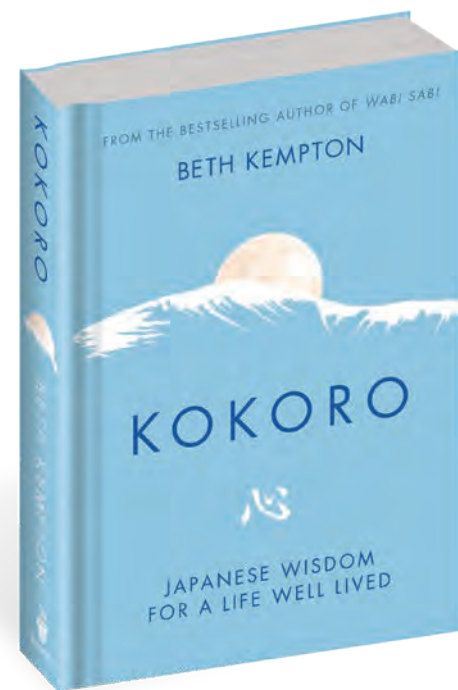

Kokoro

Beth Kempton

Kokoro is an invitation to cultivate stillness and contentment in an ever changing, uncertain world, inspired by ancient and contemporary Japanese wisdom. Drawing on a thousand years of Japanese literature, culture, and philosophical ideas to explore the true nature of time and what it means to be human, *Kokoro*, which mysteriously translates as "heart mind," is a meditation on living well.

Join Japanologist Beth Kempton on this life-changing pilgrimage far beyond the tourist trail, to uncover the soul of the country, its people, and its deeply buried wisdom. Distilling insight from a rich variety of sources, from centuries old poetry and ancient Zen texts to martial arts teaching and contemporary philosophy, alongside the real life stories of modern day pioneers, *Kokoro* offers a gentle and inspiring take on what it truly means to be happy and the heart of what really matters, so readers can live each day with wonder and ease.

A midlife meditation on what it means to live well by embracing impermanence

- Much anticipated follow up to *Wabi Sabi* (9780062905154) which has sold over 275,000 copies and been translated into 25 languages. The author has an engaged audience totaling over 365,000 followers and newsletter subscribers.
- Inspired by ancient and contemporary Japanese wisdom. The author draws on a thousand years of Japanese literature, culture, and philosophical ideas.
- Speaks to the 33.6% of US adults who describe themselves as "more spiritual than religious." The demand for spiritual guidance is on the rise.

OCTOBER 2024

256 pages; 5 x 7; One-color; Illustrations throughout
Hardcover; \$25.00 US
 ISBN 978-1-63586-928-6



Beth Kempton is a writer mentor and self-help author, whose books include the best-selling *Wabi Sabi*. Kempton has made it her work to uncover life lessons from Japanese culture, words, and ritual. She holds two degrees in Japanese and is a qualified yoga teacher and Reiki Master, trained in the Japanese tradition in Tokyo. She is founder of Do What You Love, a company which produces inspiring online courses for living well.

HOLLY BOBBINS PHOTOGRAPHY



Stunning artwork by award winning artist Ofra Amit accompanies each essay.

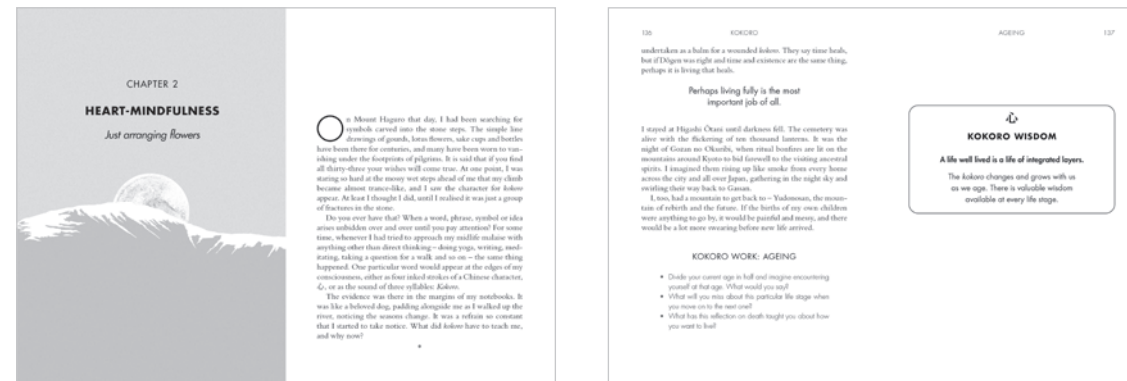

When you learn to live guided by the light in your kokoro, everything changes, and anything is possible.

Accessible handbook now expanded with full-color design

- **Classic book completely revised.** Now updated with more recipes, an expanded herb list, and the most up to date information on natural remedies for babies and children.
- **Rosemary Gladstar is one of the most trusted names** in herbal medicine and natural health. A practitioner for more than 50 years, Gladstar is the author of 10 books, with a total of more than 1 million copies in print.
- **Safe, gentle, effective remedies for the most common childhood ailments,** all easy to make at home. Features recipes using natural approaches for easing the symptoms of ear infections, colds and flu, colic, insect bites, diaper rash, and more.

SEPTEMBER 2024
208 pages; 7 x 9; Full-color
Paper; \$19.99 US
ISBN 978-1-63586-828-9

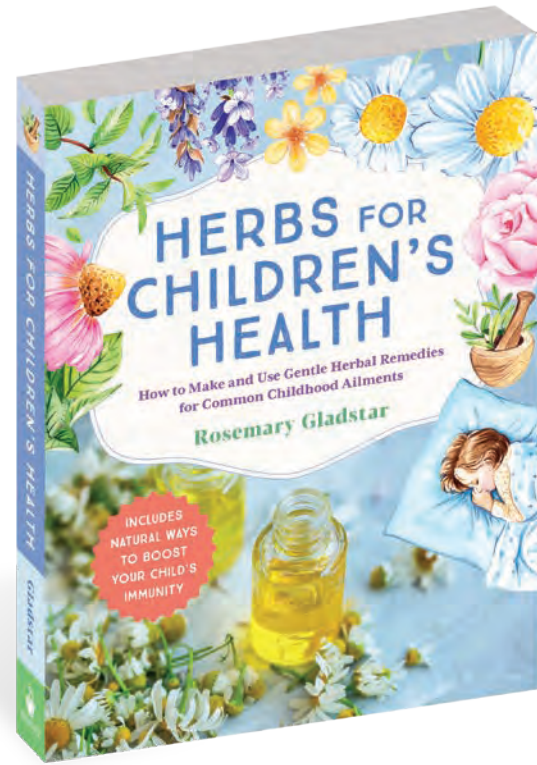

Herbs for Children's Health, 3rd Edition
Rosemary Gladstar

The expanded new edition of the best selling handbook for parents seeking gentle, safe, homemade remedies for children's most common ailments, from Rosemary Gladstar, one of the most trusted names in natural medicine.

In this highly accessible handbook, expert Rosemary Gladstar shares dozens of safe and gentle natural recipes, along with simple care advice, for addressing children's everyday health needs. Parents of babies and toddlers will discover how easy it is create a home medicine cabinet of herbal remedies for addressing everything from colic to cradle cap, diaper rash, earaches, colds, cuts, teething, and more. Gladstar's child tested recipes feature appealing flavors in forms kids love, including teas, syrups, herbal ice pops, "candy" balls, and herbal baths. A quick reference guide outlines the recommended uses for all the child-safe herbs, including chamomile, milky oats, peppermint, lemon balm, and licorice. With her commonsense guidance and time tested wisdom, Rosemary Gladstar is the reassuring advisor every parent would like to have around the home.

Rosemary Gladstar is the best selling author of *Rosemary Gladstar's Medicinal Herbs: A Beginner's Guide*, *Fire Cider!*, and *Rosemary Gladstar's Herbal Recipes for Vibrant Health*, which draw on her 40 plus years of experiences studying and teaching about the healing properties of herbs. She is a world renowned educator, activist, and entrepreneur, and the founding director of Sage Mountain Herbal Retreat Center, the International Herb Symposium, and the New England Women's Herbal Conference. She lives in Vermont.



Farm-Raised Kids
Katie Kulla

Essential parenting advice and practical strategies for engaging kids in farm life—to create opportunities for play and learning, to foster resilience and independence, and to keep kids busy while you're running your farm or backyard homestead.

In this first ever book on the topic, author Katie Kulla offers her own hard won wisdom, gleaned from more than a decade of raising kids while running a CSA farm with her husband. The book also features invaluable advice and insights from other farmer parents and a wealth of practical tips and ideas for how to engage children on the farm—including activities for learning and play, and suggestions for how to enlist kids in chores and other farm responsibilities. Included are profiles of diverse farm families across a spectrum of racial and gender identities, to represent the face of farming today.

Essential parenting advice to foster resilience and independence

- **From infants to teens.** From how to work with an infant in tow to how much responsibility to give teenagers, author Katie Kulla and her fellow farmer parents offer advice for every stage of childhood.
- **In the first book of its kind, *Farm-Raised Kids* offers essential advice and strategies for engaging kids in farm life to create opportunities for learning and play.**
- **From diverse farmers who have "been there."** The author draws on her own hard won experience raising kids on a farm, and incorporates advice from a diverse range of farm families.

OCTOBER 2024
240 pages; 6 x 8; full-color
Paper; \$24.99 US
ISBN 978-1-63586-671-1

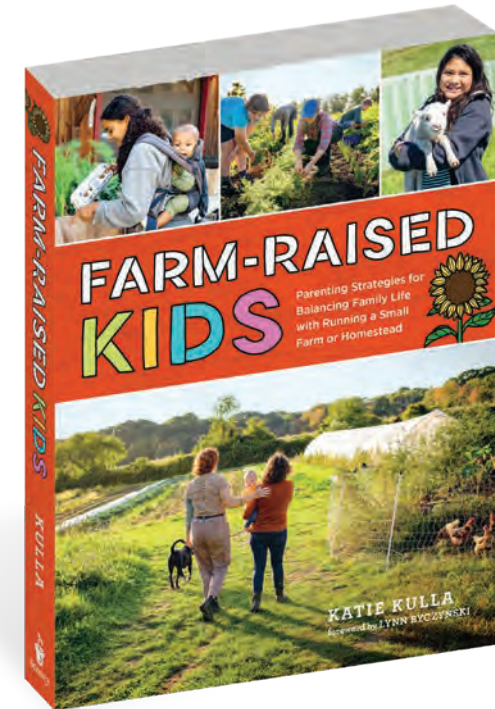

Katie Kulla is a farmer, author, and illustrator writing about farming, seasonal eating, nature, and family life. She and her husband started farming in Oregon in 2006 and have two children who were born on the farm and are homeschooled. Katie co-hosts the *Growing for Market* podcast and her writing has been published in *Taproot*, *Growing for Market Magazine*, *Farmer-ish*, *Geez*, and *GreenPrints*.



Easy-to-make herbal remedies for addressing children's most common ailments along with simple care advice.



Includes tips for having kids connect with the seasons of the natural world, to learn responsibility, resilience, and self-confidence.

Beloved poetry anthologies, now in a giftable boxed set

- **Three best selling anthologies** of contemporary poetry—*How to Love the World*, *The Path to Kindness*, and *The Wonder of Small Things*— in a collectible boxed set, with four poem prints suitable for framing.
- **Curated collection** of accessible, uplifting, contemporary poetry from a diverse range of voices. Appeals to introductory readers of poetry as well as dedicated fans.
- **Special bonus feature:** Four 5x7 frameable illustrated poem cards, on premium FSC paper, of poems by Rosemerry Wahtola Trommer, Kimberly Blaeser, Paula Gordon Lepp, and a new poem by James Crews.

SEPTEMBER 2024

656 pages; 5½ x 7½; Three 5x7 paperbacks and four 5x7 broadsides in a slipcase, shrink-wrapped
Boxed Set; \$45.00 US
 ISBN 978-1-63586-863-0

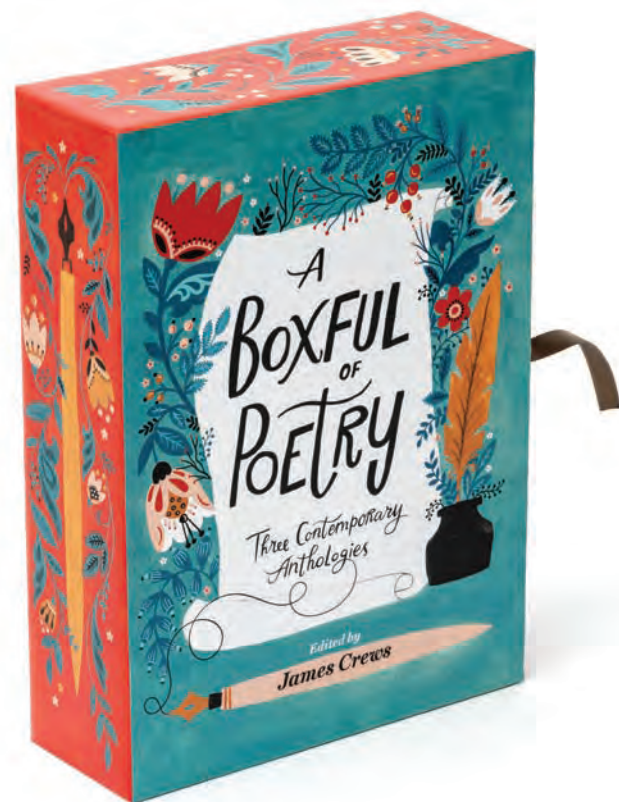

Boxful of Poetry

EDITED BY JAMES CREW

James Crews's three anthologies of contemporary poems celebrating hope, wonder, kindness, and connection are beautifully packaged in a gift box set along with four illustrated poem cards suitable for framing.

These are the poems our world needs now. Together, the three books include over 300 poems by a diverse selection of leading and emerging contemporary poets, including Amanda Gorman, Ross Gay, Ada Limón, Jane Hirshfield, Tracy K. Smith, Julia Alvarez, Ellen Bass, Danusha Laméris, Li Young Lee, Naomi Shihab Nye, Joy Harjo, Joseph Bruchac, Nikita Gill, Linda Hogan, Mark Nepo, Alberto Ríos, and others. Special bonus feature: four frameable prints of poems by Rosemerry Wahtola Trommer, Kimberly Blaeser, Paula Gordon Lepp, and a new poem by James Crews.

James Crews is the editor of best-selling poetry anthologies, including *The Wonder of Small Things*, *The Path to Kindness*, and *How to Love the World*, which has over 100,000 copies in print, *Healing the Divide*, and is the author of the essay collection, *Kindness Will Save the World*. He has been featured on NPR's *Morning Edition*, and in *People Magazine*, *The New York Times Magazine*, and *The Washington Post*. Crews lives with his husband in Southern Vermont.



Includes three anthologies of contemporary poetry— in a collectible boxed set with a special set of four poem prints suitable for framing.



Heart of the Hive

Hilary Kearney

An intimate, inside view of how honey bees experience the world and how their fascinating matriarchal society functions. Expert beekeeper and swarm catcher Hilary Kearney offers a unique window into the social lives and biology of these remarkable creatures, accompanied by the photos of world renowned bee photographer Eric Tourneret.

Readers will be awestruck by the hive as superorganism and how the individual bee lives and behaves within it, perfectly suited to each specific job it performs. From their intricate dances and information-rich pheromones to how they learn, remember, and sense and respond to their environment, this immersive journey into the world of bees offers an entirely new perspective on the wisdom of nature and our relationship to it.

Expert beekeeper offers a unique window into the world of bees

- **Popular topic** according to Bee Culture magazine, there are now more than 120,000 hobby beekeepers in the United States, many of them in urban areas. While hobby beekeeping has boomed, many other people are simply interested in learning more about these fascinating insects.
- **From the author of *Queenspotting***, Hilary Kearney offers an intimate, inside view of honey bees through her brand Girl Next Door Honey: 111K Instagram followers, 35K Facebook followers.
- **Photos by renowned photographer Eric Tourneret**, recognized internationally as “the bee photographer.” His work was recently exhibited at the United Nations in Geneva, Switzerland, and has appeared widely at exhibitions and museums around the world.

SEPTEMBER 2024

200 pages; 5½ x 7½; Full-color
Hardcover; \$28.00 US
 ISBN 978-1-63586-483-0



Hilary Kearney is the author of *Queenspotting* and the creator of Girl Next Door Honey, a beekeeping business that offers educational opportunities to hundreds of new beekeepers each year. She maintains the blog *Beekeeping Like A Girl* and her writing on bees has appeared in *Modern Farmer* and *Grit* magazines. Her work has been the subject of features in *Huffington Post*, *Vogue*, *Mother Earth News*, and other outlets. She rescues wild bee colonies and manages around 90 hives in her hometown of San Diego, California.



Includes stunning photography by world renowned bee photographer Eric Tourneret.

An inspiring and definitive guide to social activism for all types of crafters

- **A how-to guide** for becoming an activist specially designed for crafters and makers. Includes case studies, checklists, and a step-by-step strategy for planning an activist campaign using craft as a tool.
- **Author is a leader in the craftivism movement.** Shannon Downey has cultivated an engaged and passionate community through her two popular websites—Badass Cross Stitch and Seriously Badass Women—and social media channels.
- **Engaged audience** From the AIDS Memorial Quilt to the Pussyhats Project at the 2017 Women’s March, craftivism—where handcrafts and activism meet—is a powerful and growing movement.

OCTOBER 2024
264 pages; 5½ x 8½; Full-color
Paper; **\$19.99 US**
ISBN 978-1-63586-890-6

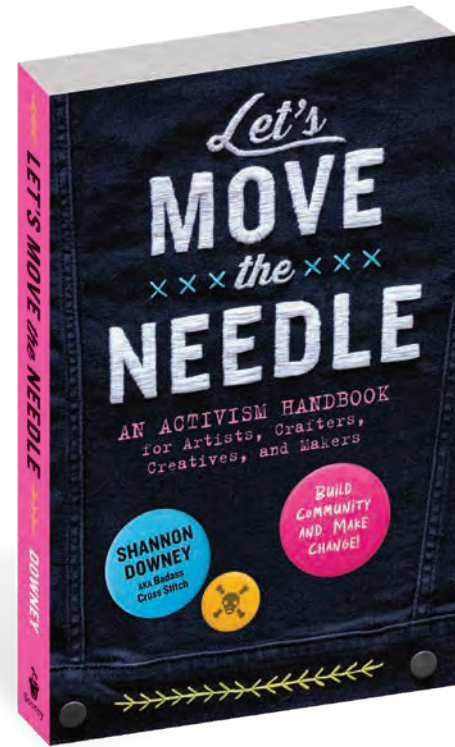

Let's Move the Needle

Shannon Downey

Shannon Downey is the founder of Badass Cross Stitch and Seriously Badass Women, and is an artist, activist, craftivist, community builder, and general instigator. Her award winning work has been featured in outlets including *Vogue*, *Harper's Bazaar*, *Atlas Obscura*, *Fast Company*, and *iD*, and books including *Notorious RBG* and *Signs of Resistance*. She is on the faculty at Columbia College Chicago and currently lives in Chicago, Illinois.

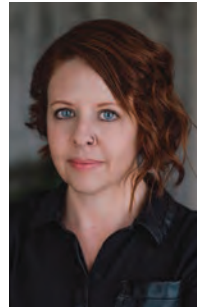

In this inspiring and definitive guide to social activism for all types of crafters, noted artist and community builder Shannon Downey provides a detailed framework for building strategic action plans, accompanied by self-reflective activities and dozens of stories of other craftivists.

Craftivism—where handcrafts and activism meet—is a powerful and growing movement. This book is for anyone who wants to make a point creatively. Author Shannon Downey provides a roadmap and accessible tool kit for every leg of their activist journey featuring exercises, and prompts, along with practical stories about the work of other art activists across mediums and throughout history.



Delve into the underlying roots of problems to focus activism on making strong, and long-lasting change

A fresh, modern take on paint by number features 20 frame-worthy mushroom images

- **Paint by number for today's DIYer.** Coloready reinvents this easy craft with stylish designs, easy-to-follow painting instructions, and color swatches for blending acrylic paints to get an exact match.
- **Original designs highlight the key features of 20 distinctive mushrooms.** Beautifully rendered images show off the distinctive colors, shapes, and markings of wild mushrooms, from the deadly to the edible.
- **A beautiful package with premium art paper.** Suitable for painting with acrylics or coloring with markers, colored pencils, or pastels, the template pages pull out easily and fit in a ready made 8 x 10 frame.

SEPTEMBER 2024
112 pages; 8 x 10; Full-color Illustrations throughout
Paper; **\$24.99 US**
ISBN 978-1-63586-875-3

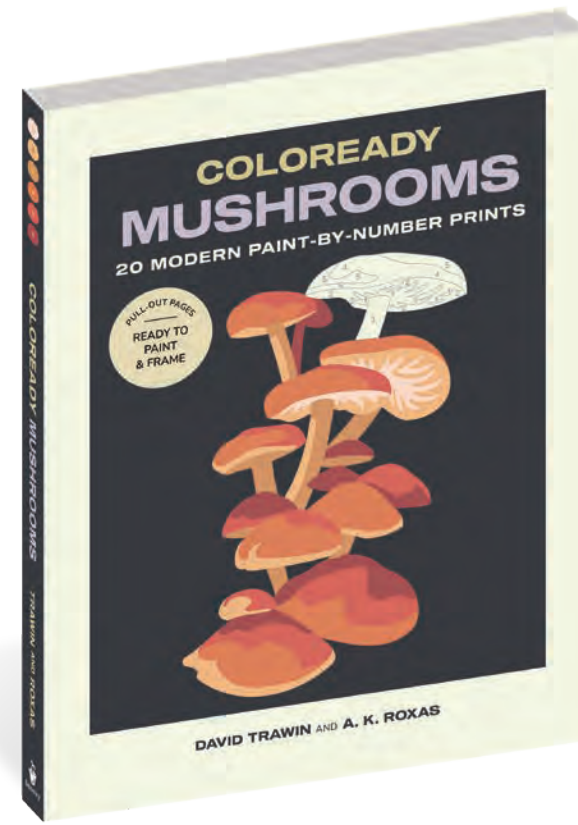

Coloready Mushrooms

David Trawin and A. K. Roxas

Paint by number has been updated with a hip, contemporary look in this collection of 20 images of mushrooms, printed on premium art paper, perfect for framing. Each of the images are accompanied by step-by-step instructions and profiles of each mushroom.

Everyone can awaken their inner artist and create beautiful home décor with the Coloready paint by number original mushroom design collection. From the signature red cap and white spots of the Amanita muscaria to the Inky Cap's subtle shades of gray, the realistic features of each of the 20 mushrooms are highlighted and described in the accompanying text. Every template includes a swatch palette and instructions for mixing standard acrylic paints for a perfect color match. The completed 8" x 10" sheet pulls out and fits handily in a ready-made frame.



David Trawin is a graphic designer and the creative force behind Coloready, which offers a modern spin on the paint-by-number art kit. Before starting Coloready, Trawin worked designing everything from T-shirts for a comedy brand, to alcohol graphics and tech products. He lives in New Jersey with his wife and co-writer, A. K. Roxas, and their two children.

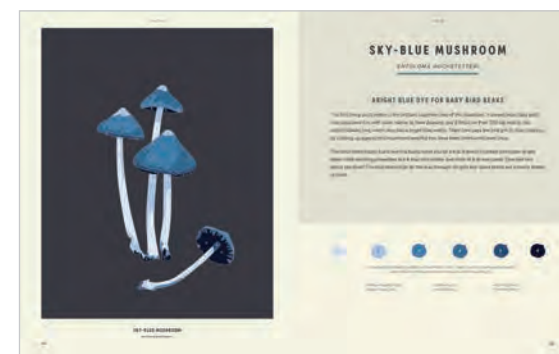

The templates are printed on beautiful, high-quality, watercolor-style paper, and each of the 20 mushroom templates is printed on both a cream background and a black background.

One-of-a-kind book plus oracle deck designed for fermentation fans

- **A fresh approach to fermentation.** Guided meditations on the properties or themes of each ferment—transformation, adventure, or celebration, for example—help readers think creatively about the gifts of that particular food or drink.
- **Irresistible gift package.** Includes a deck of 36 colorfully illustrated oracle cards, packaged with a guidebook that features expanded readings on each card's symbolism, plus 38 recipes to spark curiosity and creativity.
- **Fermentation expert.** Author Julia Skinner teaches fermentation courses internationally and is highly respected in the food world.

OCTOBER 2024

5¼ x 7¾; Full-color illustrations throughout; includes a 120-page book and 36 cards
Hardcover; \$28.00 US
 ISBN 978-1-63586-832-6

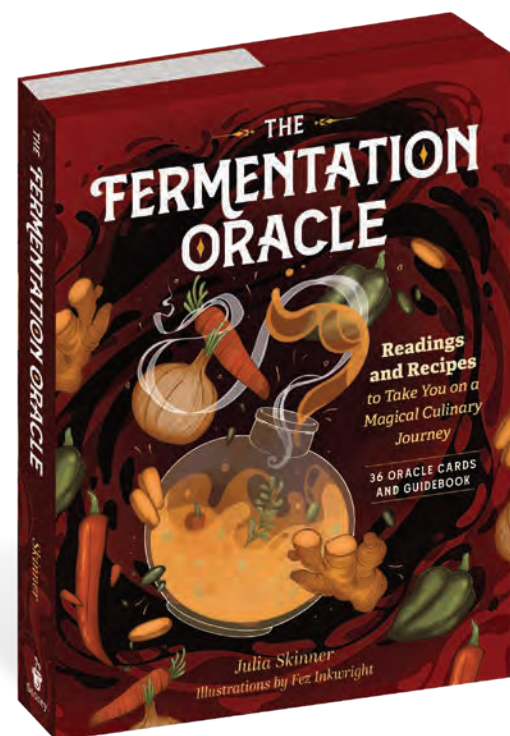

Fermentation Oracle

Julia Skinner

Julia Skinner is the author of *Our Fermented Lives* and the founder and director of Root, a fermentation and food history company that bridges the gap between modern people and historic food. She is the first food writer to be awarded two 40 Under 40 awards in the same year. Her work has been featured in Vox, Eater, Business Insider, and BuzzFeed. She lives in Atlanta, Georgia.



Award winning author Julia Skinner combines her passion for making fermented foods with her fascination for the transformative, magical aspects of the process in this one-of-a-kind book plus oracle deck specially designed for fermentation fans.

Fermentation is an adventure, whether you're collecting new cultures from foreign lands, riffing on a traditional recipe to create a totally new food, or allowing the process to lead you to moments of self reflection. In *The Fermentation Oracle*, author Julia Skinner opens a portal to new culinary and personal explorations by sharing 36 guided meditations on the properties of each ferment, intended to help you think creatively about the gifts of that particular food or drink, access intuition, and navigate each day's joys and problems more thoughtfully. The book is packaged with a deck of 36 lavishly illustrated oracle cards to spark your next culinary adventure and 38 creative recipes inspired by the readings that accompany them.

Julia Skinner's oracle readings and recipes are designed to encourage the connection between creativity and intuition in the kitchen.

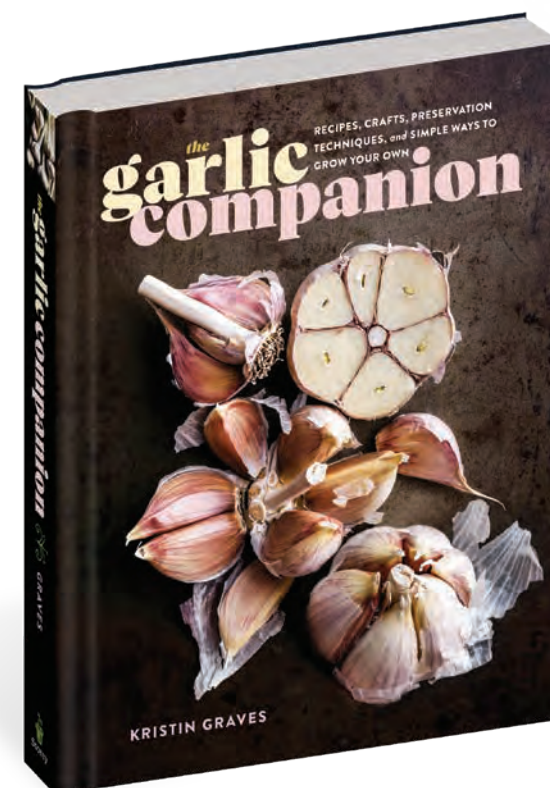

Garlic Companion

Kristin Graves

A gift book with stunning original photography throughout, celebrating the world's love of garlic—filled with fun facts, fascinating lore, 36 mouthwatering recipes, unique ideas for preparing, preserving, and enjoying garlic, as well growing advice for home gardeners.

In *The Garlic Companion*, author and garlic devotee Kristin Graves celebrates the wonderful world of this pungent herb, including how to plant, grow, harvest, and preserve it, as well as how to use both the bulbs and the scapes (flowering stems) in decorations and crafts such as garlic braids and wreaths. She has created 36 recipes that focus on using garlic in all its various forms—from Garlic Scape Refrigerator Pickles to Honey Garlic Ribs to Black Garlic Chocolate Chip Cookies—and offers dozens of ideas for celebrating the garlic harvest.

A vibrant celebration of all things garlic

- **Stunning gift book for garlic lovers everywhere.** With gorgeous lifestyle photography, accessible information, and mouthwatering recipes for a broad audience of garlic lovers.
- **One of the top three herbs.** Along with parsley and cilantro, garlic is consistently one of the top ingredients used by home cooks. Its health-promoting qualities have earned it a place in kitchens everywhere and a long history of use in traditional herbal medicine.
- **Unique ways to celebrate garlic.** From creating garlic scape floral arrangements and garlic wreaths to feasting on garlic confit and black garlic mac and cheese, there are dozens of ways to enjoy garlic.

SEPTEMBER 2024

224 pages; 7 x 9; Full-color
Hardcover; \$26.00 US
 ISBN 978-1-63586-686-5



Kristin Graves is a fifth generation farmer in Alberta, Canada. In addition to her vegetable CSA, she focuses on growing fresh garlic for local markets and creating value added products to ship across Canada. Her website is www.fifthgengardens.ca, and her Instagram handle is @fifthgengardens.



With 36 garlic-forward recipes, as well as spice mixes, craft ideas, floral arrangements, growing instructions, and inspiration for garlic-themed dinners.

A boxed set of three books in the Wild Wisdom series including 108 oracle cards and a divination mat

- **A deluxe gift set.** Includes *The Illustrated Herbiary*, *The Illustrated Bestiary*, and *The Illustrated Crystallary*, a set of 108 oracle cards, and a full color, 15 3/8 x 17 3/4 divination mat that can be used to create more complex readings from the cards.
- **A beloved best-selling author.** Maia Toll's books have more than 262,000 copies in print combined, and her strong and constantly growing platform continues to generate new readers.
- **Stunning art by Kate O'Hara.** The rich, evocative artwork of Kate O'Hara is adored by witchy/occult fans as well as herb, nature, and crystal enthusiasts.

OCTOBER 2024

504 pages; 6 1/4 w x 8 1/2 h x 3 3/4 d; Full-color; includes 108 oracle cards and divination mat
Hardcover; \$60.00 US
 ISBN 978-1-63586-864-7

Maia Toll's Wild Wisdom Collection

Maia Toll

Tap into the wild wisdom of 108 plants, animals, and crystals in this boxed set of award-winning books by best-selling author Maia Toll. The set features dynamic illustrations by artist Kate O'Hara, as well as an oracle divination mat to help guide your reflections.

Author Maia Toll explores how meditating on the traits of particular plants, animals, and crystals can elucidate our own intentions, inform our actions, and offer wisdom and insight. In addition to the three books in the Wild Wisdom series—*The Illustrated Herbiary*, *The Illustrated Bestiary*, and *The Illustrated Crystallary*—this lushly illustrated boxed set features three sets of 36 oracle cards to draw on the wisdom of each plant, animal, and crystal profiled in the books. The set enables readers to use all 108 cards and the accompanying meditations in each book, together with the oracle divination mat, to explore the mystical side of the natural world, access their intuition, and navigate each day with a greater sense of equanimity and connection.

Maia Toll is the award-winning author of the Wild Wisdom series, which includes *The Illustrated Herbiary*, *The Illustrated Bestiary*, *The Illustrated Crystallary*, and *Maia Toll's Wild Wisdom Companion*, as well as *Letting Magic In* and *The Night School*. Her bestselling books have been translated into multiple languages. Toll is the co-owner of the retail store Herbiary, with locations in Asheville, NC, and Philadelphia, PA. You can find her online at maiatoll.com.



Layer all three decks of plants, animals, and crystal cards together for unique oracle card readings.



100 vintage postcards and everything needed to transform them into one of a kind works of art

- **Vintage with a modern twist.** The vintage reproduction and ephemera market is popular in paper, clothes, and design. 60% of all US consumers regularly buy vintage, according to new research
- **Includes cards, stickers, collage papers, and instructional booklet.** The kit includes 100 vintage reproduction postcards, colorful sheets of stickers including speech bubbles and illustrations, a variety of collage papers, plus an instructional booklet.
- **Creativity in a box.** Crafters, paper enthusiasts, scrapbookers, collage makers, and anyone looking for a creative activity will enjoy making one-of-a-kind postcard art.

SEPTEMBER 2024

6 w x 8 1/2 h x 3.6 d; Full-color; includes a 64-page book, 100 postcards, 5 patterned paper sheets, and 6 sticker sheets in a gift box
Kit; \$27.99 US
 ISBN 978-1-63586-619-3

Vintage Postcard Collage Kit

Kelly Lynch

Crafters, scrapbookers, and collage enthusiasts will love this kit-in-a-box, with 100 vintage postcards and everything needed to transform them into one-of-a-kind works of art to share and display.

Altering postcards is a fun and easy way for anyone to get creative and make a quirky, unique piece of paper art to send to a friend, use as a place setting, give as party favors, use for holiday, birthday, or greeting cards—or simply hang on the wall. The kit includes reproductions of 100 intriguing vintage postcards from 1900 to the 1960s, featuring places, people, and objects that invite playful tampering, plus 6 sticker sheets and 5 patterned paper sheets for collage. The accompanying 64-page full color booklet is a hands-on guide to materials, techniques, tips, and step-by-step examples showing a range of methods using painting, embroidery, and layered collage. A gallery of artist-made altered postcards offers additional inspiration and ideas for pushing the envelope on creativity.



Kelly Lynch is a professional graphic designer who loves playing with ideas in various mediums. During her career she has lived and worked in New York, Paris, and Amsterdam. Lynch is an enthusiastic member of the Metropolitan Postcard Club of New York and her favorite place to spend time is in the Metropolitan Museum of Art. She lives in south-western New Hampshire with her trusty Coton de Tulear.

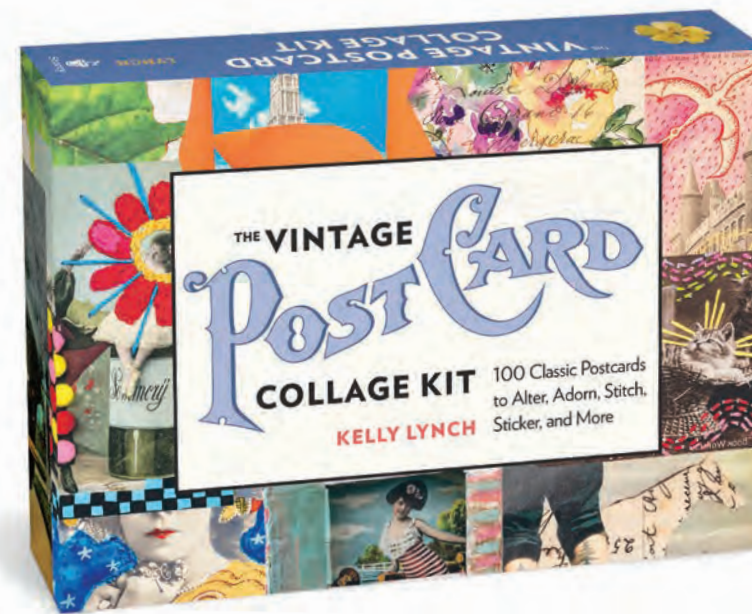

Packaged in a sturdy keepsake box with a magnetic closure, this kit includes reproductions of 100 vintage postcards, a 64-page guidebook, 5 patterned collage sheets, and 6 sticker sheets.

A whole new way to connect with nature at night from the best-selling series

- New title in the Backpack Explorer series features a real magnifying glass, colorful ID photos, nature games and activities, 50 stickers, and a log for recording nature finds.
- Boosts early STEAM education by fostering early science learning with field guides, sensory games, nature scavenger hunts, night sky activities, and fun facts about nocturnal animals, constellations, and planets
- Backpack Explorer fans can extend their learning with the new free online companion game Backpack Explorer: Find the Animals!

SEPTEMBER 2024

48 pages; 7 7/8 x 9 3/4; Full-color; plus 3 sticker sheets, magnifying glass, & fold-out journal
Hardcover; \$14.99 US
 ISBN 978-1-63586-847-0

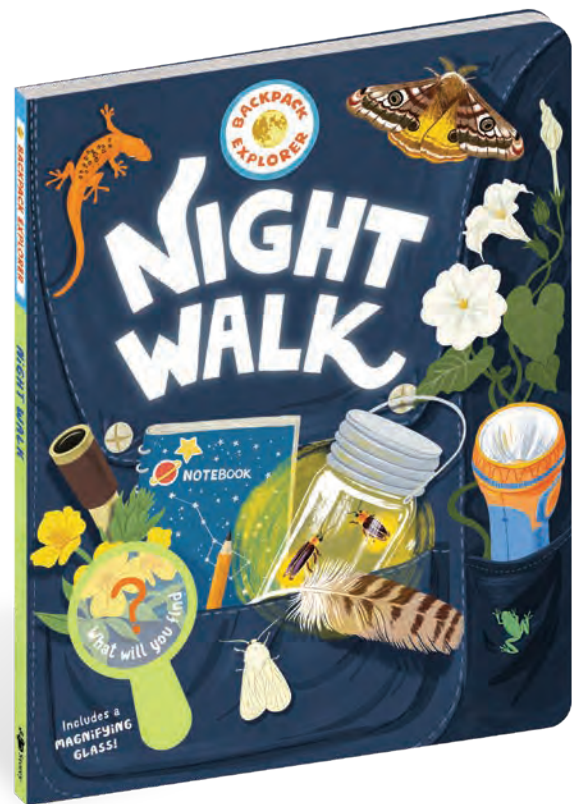

Backpack Explorer: Night Walk

Editors of Storey Publishing

Step outside after dark and explore the outdoors! Packed with nighttime scavenger hunts, flashlight games, and field guides for nocturnal animals, insects, and birds, this nighttime activity book—complete with a real magnifying glass, stickers, and a fold-out journal—is the perfect take-along nature exploration guide for kids aged 4 to 8.

In the eighth book of the Backpack Explorer series, junior naturalists search for owls, bats, salamanders, stars, planets, and more. *Backpack Explorer: Night Walk* is packed with prompts and activities, including 12 interactive field guides, sensory scavenger hunts, activities such as learning about the phases of the moon, listening to the noises of the night, and looking for constellations in the sky. Curious kids will discover the great outdoors with this unique guide to the natural world.



ADVENTURE, EXPLORE, DISCOVER!

Colorful take-along field guides for kids encourage the littlest explorers to look, listen, touch, play, and discover the wonders of the natural world. Each book includes scavenger hunts, kid-friendly nature activities, a magnifying glass and stickers!



Backpack Explorer: On the Nature Trail
 \$12.95 US
 ISBN 978-1-63586-197-6



Backpack Explorer: Beach Walk
 \$12.95 US
 ISBN 978-1-61212-902-0



Backpack Explorer: Bird Watch
 \$12.99 US
 ISBN 978-1-63586-251-5



Backpack Explorer: Bug Hunt
 \$12.99 US
 ISBN 978-1-63586-313-0



Backpack Explorer: Rock Hunt
 \$12.99 US
 ISBN 978-1-63586-553-0



Best-selling kids nature guides include:

- Full-color
- 48 pages; 7 7/8 x 9 3/4
- Magnifying Glass
- Hardcover Format
- 3 Sticker Sheets
- Pull-out Map/Journal

For ages 4+



Backpack Explorer: Discovering Trees
 \$12.95 US
 ISBN 978-1-63586-346-8



Backpack Explorer: Plants And Flowers
 \$12.99 US
 ISBN 978-1-63586-675-9



Backpack Explorer Stickers: Nature Adventure
 \$14.99 US
 ISBN 978-1-63586-862-3



Backpack Explorer 5-Book Set with Nature Collection Box
 5-book boxed set with sturdy nature collection box;
 240 pages; 7.89 x 9.65
 Full-color
\$64.99 US
 ISBN 978-1-63586-666-7



Every page features information about nature after dark, including nocturnal animals and insects, constellations, and planets.

PLAY AND LEARN WITH THE COMPANION BACKPACK EXPLORER ONLINE GAME!

10th anniversary edition with new recipes and a fresh new look

- Includes 20% new content (350,000 copies in print). The classic best-selling children's cookbook for kids aged 8 and up has been expanded to feature 73 recipes, including 15 new ones.
- Step-by-step photos for every recipe make it easy for kids to cook on their own. Specially written for kids aged 8 and up, the recipes feature fresh ingredients, easy kitchen skills, and favorite kid dishes for every meal of the day.
- Includes bonus pop out recipe cards, mealtime game cards, as well as dozens of stickers for labeling homemade dressings, salsa, pestos, cocoa mixes, and more.

OCTOBER 2024

188 pages; 9 x 9½; Full-color; includes 3 sticker sheets and 3 cardstock sheets
Hardcover; \$19.99 US
 ISBN 978-1-63586-779-4



Cooking Class, 10th Anniversary Edition
 Deanna F. Cook

Deanna F. Cook is the award-winning author of cookbooks for kids, including the best selling *Cooking Class*, *Baking Class*, *Cooking Class Global Feast!*, and *Kids Cook Dinner*. She served as the creative development director at *FamilyFun* magazine and has been an editor at Scholastic, Disney, and Kidstir.com. She lives in western Massachusetts and can be found online at deannafcook.com.



The 10th anniversary updated edition of the classic introductory guide for kids, **Cooking Class**, features recipes for nourishing meals kids can make themselves by following the easy, step by step photographic instructions.

The 10th anniversary edition expands on the original to include a total of 73 recipes, including 15 new ones, new photography, and a new format. With recipes for everything from breakfast sundaes and French toast on a stick to homemade peanut butter, banh mi sandwiches, smoothies, spring rolls, chicken curry, and pizza soup, kids learn that cooking from scratch using fresh ingredients can be fun and delicious. In addition to mastering their favorite foods, budding young cooks learn kitchen skills, from cutting and whisking to frying, grilling, sautéing and simmering. No meal would be complete without dessert, and **Cooking Class** has it covered, with snickerdoodles, lemon squares, and more. Bonus pull-out pages include conversation starter games, recipes cards, and stickers for labeling their homemade food to share with others.



Covers essential cooking terms, how to read a recipe, and includes pull-out place cards, recipes cards, and stickers for labeling homemade food to share with others.

100 tinkering projects and prompts to inspire kids aged 8 to 12 to explore scientific principles

- Makerspace activities kids can do themselves. One hundred open ended activities with photographs inspire kids to independently build, engineer, invent, construct, and play with household materials, wood scraps, electronics, water, and more in new, unexpected ways.
- Builds STEAM skills. Fun, inspiring prompts and explorations are based in science, technology, engineering, and art, and help kids become better problem solvers.
- Written by a museum educator. Author Ryan Jenkins runs the Wonderful Idea Company and developed activities at the Tinkering Studio at the Exploratorium for 10 years.

OCTOBER 2024

168 pages; 8½ x 10½; Full-color
Hardcover; \$29.99 US
 ISBN 978-1-63586-751-0
Paper; \$19.99 US
 ISBN 978-1-63586-809-8



Tinkering Workshop
 Ryan Jenkins

Gather some basic tools and supplies from a hardware store, garage, basement, woodshop, or recycling bin. Now get ready to tinker, explore, and engineer with screws, bendy wire, metal washers, plastic pipes, dowels, electronics, LED lights, and more!

Makerspace educator Ryan Jenkins inspires kids aged 8 to 12 to look at familiar supplies in new and unexpected ways, to think with their hands, troubleshoot tricky constructions, and sharpen their problem solving skills. Kids are invited to imagine how to use the supplies on hand with projects, such as building Flexible Forts with cardboard and screws, making Art Robots with hobby motors, constructing a Water Factory with plastic pipes, balancing Sky Trams on strings, and engineering Surprising Switches with wire and foil. As they build, they'll learn about balance, center of gravity, comparative measuring, electricity, and more. Engaging photography jump starts hours of curiosity and creativity. Start with a string, PVC pipe, cardboard ramp, or flexible tube—and see where it leads!



Ryan Jenkins is the co-founder of Wonderful Idea Co., a design studio that creates resources to support STEAM education and the development of 21st century skills. He's a former educator at the Exploratorium in San Francisco and developed summer curriculum for kids at the Tinkering School. He has written for *Make Magazine* and is a regular contributor to the Tinkering Studio Blog at the Exploratorium. He lives in California.



Every page encourages children to look at familiar supplies in new and unexpected ways, to think with their hands, and sharpen their problem-solving skills.

An exploration of decomposition, for readers aged 8 and up

- **Critical topic** for understanding important environmental issues, including pollution and climate change.
- **The yuck factor kids love to learn about.** Colorful illustrations of decomposing plants and animals are a fascinating way to learn science.
- **Author has a wide-reaching network** that includes the Five Colleges Consortium, the American Association of Geographers, the North American Association for Environmental Education, and other groups.

SEPTEMBER 2024

80 pages; 8½ x 10½; Full-color
Hardcover; \$18.99 US
 ISBN 978-1-63586-669-8

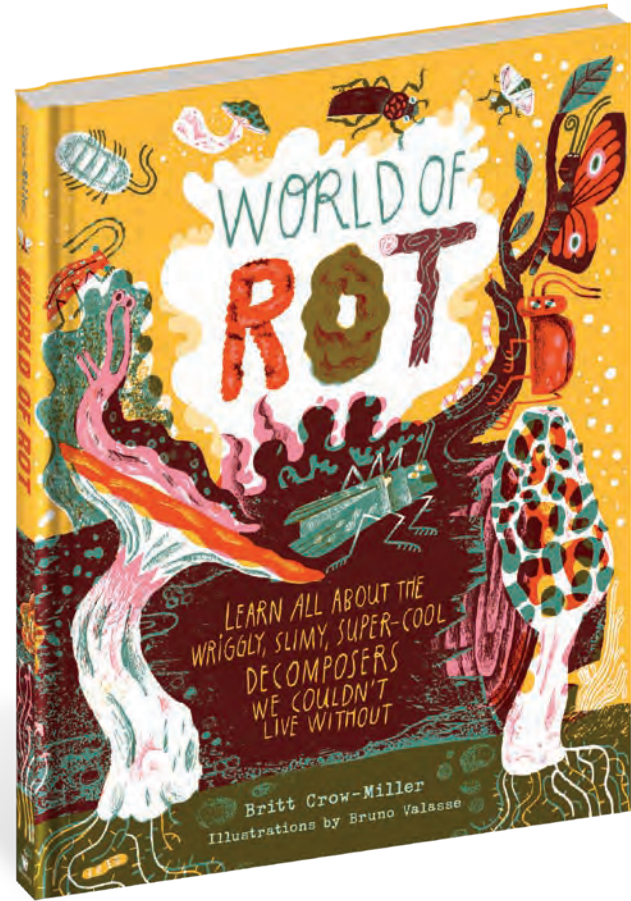

World of Rot

Britt Crow-Miller

Britt Crow-Miller is the founding director of CityWild, a nonprofit organization with the mission of inspiring curiosity about the natural world. Her sustainability related writing has been published by the *Global Water Forum*, *State of the Planet*, *Huffington Post*, and *Harvard Business School*. Crow-Miller is also on the faculty in the Departments of Environmental Conservation and Geosciences at the University of Massachusetts, Amherst, where she directs the Sustainability Science graduate program.



World of Rot takes readers on a deep dive into the process of decay, from the science behind it to an up-close and personal look at the organisms that do the dirty work to make our planet livable.

With a touch of humor and quirky full-color illustrations, kids will learn about the life recycling system happening all around us—in the sea, in the soil, and even inside our own bodies. Profiles of decomposers such as hungry fungi and familiar worms, poop-slurping butterflies, and slimy banana slugs offer something to pique the curiosity of every kid. Readers will also learn the heroic role decomposers might play in fighting climate change and eating plastic.



An up-close and personal look at the organisms that do the dirty work to make our planet livable.

Julia Rothman invites kids ages 8 and up to explore the fun of farm life

- **Companion activity book** to Julia Rothman's popular *Farm Anatomy* book, which has nearly 128,000 copies in print.
- **Interactive design.** Using her own original drawings as a starting place, Rothman invites kids to fill in journaling pages, complete puzzles and word games, create their own drawings, and explore the fun of farm life.
- **Best selling author** Julia Rothman is one of the best known contemporary illustrators, with 88,000 followers on Instagram. Her designs have been sold at Anthropologie, Crate and Barrel, and Hygge and West.

SEPTEMBER 2024

64 pages; 8 x 10; Full-color illustrations throughout
Paper; \$12.99 US
 ISBN 978-1-63586-872-2

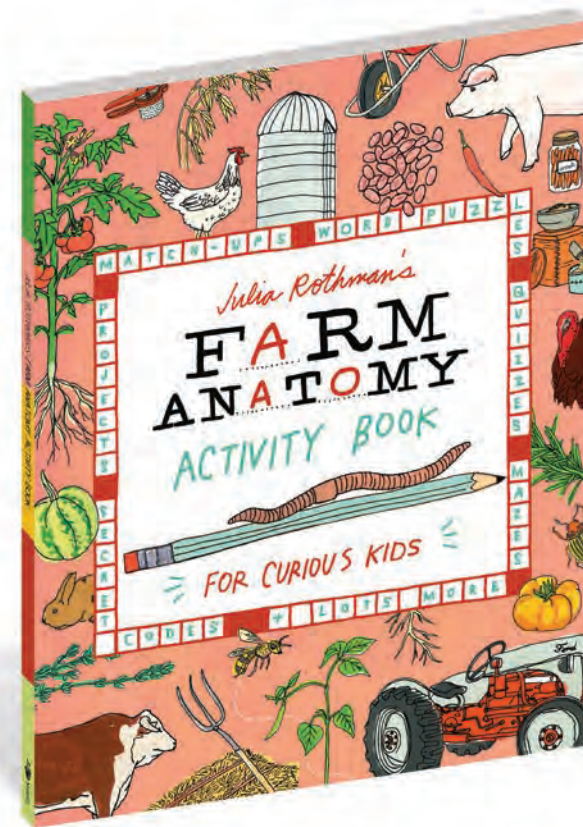

Julia Rothman's Farm Anatomy Activity Book

Julia Rothman

Julia Rothman, bestselling author and illustrator of *Farm Anatomy*, presents a companion activity book for kids ages 8 and up, with pages of creative learning activities, including matching challenges, mazes, ID and drawing exercises, word puzzles, and observational challenges.

Loaded with Rothman's original illustrations, this interactive format features fun challenges on every page, including labeling the parts of a rabbit, buzzing through a pollinator's maze, figuring out a secret farm code, identifying tools and equipment, and learning to draw a sheep and a horse. Rothman's lively collection of on the page quizzes, puzzles, and activities will intrigue and entertain you, whether you live on a farm or not.

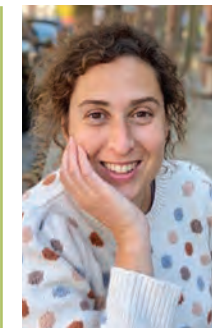

Julia Rothman is a highly acclaimed contemporary illustrator and author of many best selling books, including *Nature Anatomy*, *Farm Anatomy*, *Ocean Anatomy*, *Food Anatomy*, *Nature Anatomy Notebook*, and *Wildlife Anatomy*. Her illustrated column, *Scratch*, is featured in the *Sunday New York Times*. Clients for her illustrations and pattern designs include Target, the *Washington Post*, MTA Arts & Design, and more. She lives and works in Brooklyn, New York.

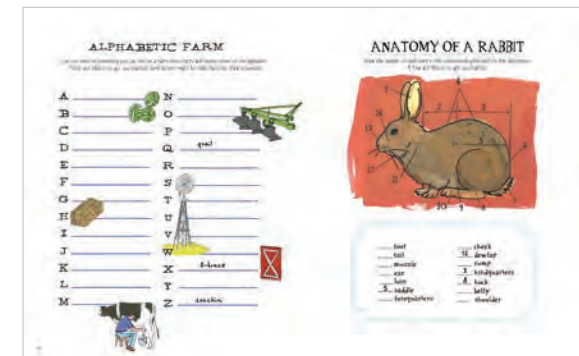
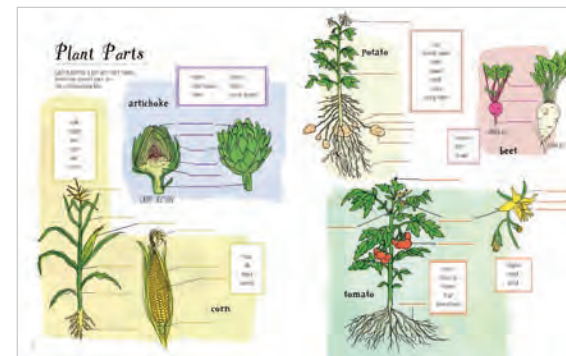

Featuring on-the-page creativity and learning activities, including mazes, word searches, drawing exercises, diary pages, and observational challenges.

60 original temporary tattoo designs and fun facts about wildlife

- 60 delightful forest animal illustrations for kids to wear. Illustrator Nora Potwora's temporary tattoos feature eye catching artwork of wolves, bears, foxes, deer, moose, and more.
- Includes fascinating facts. Information on accompanying text pages teaches fun facts kids can learn about forest wildlife while wearing their tattoos.
- Latest book in the popular Tattoos That Teach series, (200,000 copies in print) This tenth title in the series is perfect for classroom events, kids' fairs, party favors, and stocking stuffers.

NOVEMBER 2024

20 pages; 5½x 10; Full-color illustrations throughout
Notebook binding with backing board;
\$8.99 US
 ISBN 978-1-63586-800-5

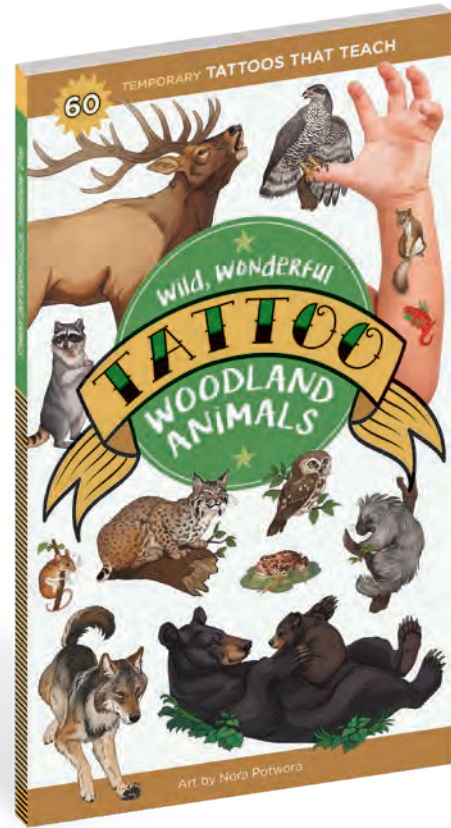

Wild, Wonderful Tattoo Woodland Animals

Editors of Storey Publishing

This colorful addition to the Tattoos That Teach series includes 60 temporary tattoos featuring realistic illustrations of the animals of the forest, including bears, moose, deer, birds, insects, and more, along with fun facts about each creature.

Nature-loving kids can show off their favorite forest animals on their arms and legs with kid friendly temporary Tattoos That Teach, featuring creatures that inhabit woodland forests. The tattoos are easy to apply by adding a bit of water and last for up to a week. In addition to the tattoos, the book features fun facts about woodland animals. Kids will love showing off these temporary tattoos and sharing their new nature knowledge with friends.



Create Your Own Mix & Match Tattoo Book Display!

Select your customized assortment of 32 titles and add **FREE** empty counter display to your order.



ISBN: 978-0-7611-7972-6
 Display measures approximately 18" wide x 10.5" high x 2" deep



The Lavender Companion
 TERRY BARLIN VESCI WITH JESSICA DUNHAM

This lavishly photographed celebration of lavender, written by an acclaimed farmer and cooking instructor, profiles the most popular lavender varieties and their recommended uses, along with the history, lore, and traditional medicinal uses. More than 40 recipes showcase lavender in delicious dishes from the kitchen as well homemade craft and body products.

Hardcover; 176 pages; 7 x 9
 Full-color
\$26.00 US
 ISBN 978-1-63586-684-1



Nettle Power
 BRIGITTE MARS

A fascinating exploration of the many uses of nettle for food, medicine, and fiber. Author Brigitte Mars shares a range of recipes for using the leaves as a tasty substitute for spinach or chard in salads, soups, and main dishes, along with healing recipes for teas, tinctures, juices, and elixirs. Colorful illustrations and curious facts make this a useful handbook.

Paper; 152 pages; 5 x 7
 Full-color
\$18.99 US
 ISBN 978-1-63586-841-8



Maia Toll's Wild Wisdom Tattoos
 MAIA TOLL • KATE O'HARA

This collection of 60 richly colored temporary tattoos feature mystical images of plants, animals, and crystals, adapted from Maia Toll's best-selling Wild Wisdom books and illustrated by Kate O'Hara, along with 10 guided-ritual cards for tapping into the symbolic power and magic of key images.

Paper; 40 pages; 5½ x 7
 Full-color
\$16.99 US
 ISBN 978-1-63586-861-6

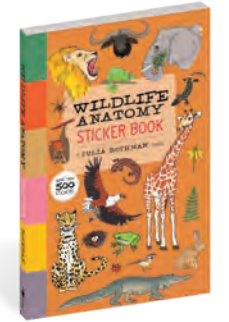

Wildlife Anatomy Sticker Books
 JULIA ROTHMAN

Julia Rothman's *Wildlife Anatomy* illustrations are featured in this collection of more than 500 stickers, including amazing mammals, birds, amphibians, and insects from around the world. From the armadillo to the aye-aye, the ocelot to the okapi, and the platypus to the panda, the most curious and fascinating animals are all included.

Paper; 56 pages; 6 x 9
 Full-color
\$12.99 US
 ISBN 978-1-635868-609-8

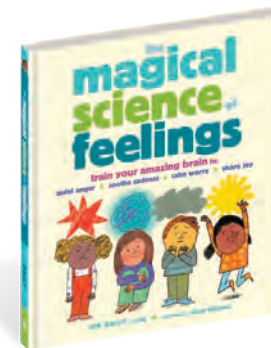

The Magical Science of Feelings
 JEN DAILY

Clinical social worker Jen Daily helps kids understand the science behind feelings, taking them on a lively tour of the brain to see where anger, anxiety, sadness, and joy start, and offering activities for calming emotions. The book provides coping skills and activities that help children ages 5 and up.

Hardcover; 64 pages; 8 x 9
 Full-color
\$16.99 US
 ISBN 978-1-63586-754-1



Herbal Activities for Kids
 MOLLY MEEHAN BROWN

A rich, colorful compendium of crafts, cooking, gardening, and nature exploration activities introduces kids ages 7 and up to the versatility and creative fun of working and playing with herbs. There are activities including how to make a pressed flower and herb collage, tie-dye fabric with turmeric, craft an herbal wreath and more.

Paper; 112 pages; 8½ x 10½
 Full-color
\$18.99 US
 ISBN 978-1-63586-584-4



Plant Pets
 BEATRICE BOGGS ALLEN & BELLE BOGGS

Ten-year-old Beatrice Boggs Allen (along with her mom, Belle Boggs) introduces the 27 easiest houseplants that any kid can grow indoors. She shares tips on caring for each plant, along with descriptions, from air plants to succulents, terrariums, and even carnivorous plants—the ones that eat insects! Kids ages 7 and up will love Bea's ideas.

Hardcover; 72 pages; 8½ x 9½
 Full-color
\$16.99 US
 ISBN 978-1-63586-767-1



Backpack Explorer Stickers: Nature Adventure
 EDITORS OF STOREY PUBLISHING

A sticker book for nature-loving kids ages 4 and up. Packed with 300 colorful stickers of plants, trees, animals, birds, bugs, and flowers, kids can use on the illustrated activity pages to track their nature finds, create habitat sticker scenes, and design their own trail map.

Paper; 48 pages; 8 x 10
 Full-color
\$14.99 US
 ISBN 978-1-63586-862-3



Animal Friends: Hello, Dogs!

EDITORS OF STOREY PUBLISHING

Dog-loving kids ages 4 and up learn all about dogs; how they see, hear, and communicate; and what makes them happy in this lively, photo-packed introduction to everything about dogs. Fifty colorful dog stickers are included, along with a fold-out activity log page for keeping track of all the dog friends they meet.

Hardcover; 48 pages; 7 x 9
Full-color
\$14.99 US
ISBN 978-1-6358-677-6



Cute, Cuddly Tattoo Cats & Kittens

EDITORS OF STOREY PUBLISHING

Cat-loving kids can wear their affection on their bodies with this collection of 50 colorful, kid-friendly temporary tattoos featuring a wide range of breeds, colors, sizes, and poses. In addition, this Tattoos that Teach book includes text pages with fun facts about cat breeds, behavior, and origins.

Paper; 20 pages; 5½ x 10
Full-color
\$8.99 US
ISBN 978-1-63586-797-8

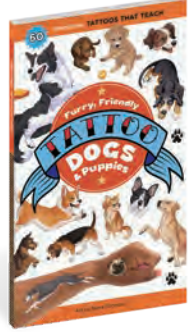

Furry, Friendly Tattoo Dogs & Puppies

EDITORS OF STOREY PUBLISHING

This collection of 60 colorful, kid-friendly temporary tattoos featuring illustrations of favorite dog breeds, playful poses, and irresistibly cute puppies. They're easy to apply with just a bit of water and last up to a week. Kids will love showing off these temporary tattoos and discovering cool dog facts.

Paper; 20 pages; 5½ x 10
Full-color
\$8.99 US
ISBN 978-1-63586-798-5



Cool, Cosmic Tattoo Stars and Planets

MEG THACHER

Explore the universe with cosmic temporary tattoos, including planets, all the phases of the Moon, a solar eclipse, a rocket, an astronaut, comets, meteors, constellations (Draco, Pegasus, and more), and dozens of shining stars. 50 colorfully illustrated temporary tattoos—plus 40 bonus star tattoos—are accompanied by amazing scientific facts about outer space.

Paper; 20 pages; 5½ x 10
Full-color
\$8.99 US
ISBN 978-1-63586-799-2



Backyard Homestead Guide to Growing Organic Food

TANYA DENCKLA COBB

The essential guide to growing a bountiful food garden—including detailed seed starting, growing, and harvesting information for 62 vegetables, fruits, and herbs, a complete companion planting guide, and organic pest control handbook. The latest addition to Storey's bestselling Backyard Homestead series of books.

Paper; 328 pages; 7 x 9
One-color
\$24.99 US
ISBN 978-1-63586-790-9



How to Forage for Wild Foods without Dying Journal

ELLEN ZACHOS

A journal for tracking the locations and seasonal dates of foraged foods. Expert forager Ellen Zachos offers essential advice for safe foraging and extensive lists of wild edibles and mushrooms for each season as a way for readers to plan their future foraging adventures. Features an easy to clean cover and elastic closure.

Paper; 192 pages; 5½ x 7
Full-color
\$16.99 US
ISBN 978-1-63586-786-2

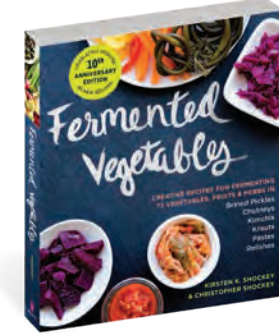

Fermented Vegetables, 10th Anniversary Edition

KIRSTEN K. SHOCKEY

Master the techniques for making sauerkraut, kimchi, pickles, and other savory, probiotic-rich foods. This easy-to-follow, comprehensive guide presents more than 120 recipes for fermenting 72 different vegetables and herbs. This full update and revision of the bestselling guide to fermenting vegetables includes new fermentation techniques and a greater emphasis on zero waste processes.

Paper; 440 pages; 8 x 9
Full-color
\$27.99 US
ISBN 978-1-63586-539-4



Soul of Gift Wrapping

MEGUMI LORNA INOUE

Acclaimed gift wrapping and packaging artist Megumi Inoue shares clever techniques and creative designs for wrapping. Detailed step-by-step photos teach Inoue's artful approach including tape-free folding, paper and fabric bows, message tags, and one-of-a-kind approaches for odd shaped items—and guide readers in creating their own unique gift presentations.

Hardcover;
208 pages; 6 x 8
Full-color
\$25.00 US
ISBN 978-1-63586-554-7



Backpack Explorer: Discovering Plants and Flowers

EDITORS OF STOREY PUBLISHING

In this Backpack Explorer nature book, kids ages 4 and up can search for wild-flowers, ferns, grasses, seeds, and more, and learn basic plant science through activities that includes scavenger hunts, a plant log, stickers, and a real magnifying glass. This book is the perfect take along for outdoor-loving kids for their next nature adventure.

Hardcover; 48 pages; 7½ x 9¼
Full-color
\$12.99 US
ISBN 978-1-6358-667-5

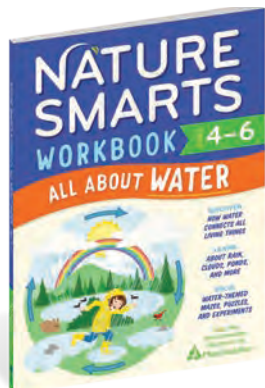

Nature Smarts Workbook: All about Water (Ages 4-6)

THE ENVIRONMENTAL EDUCATORS OF MASS AUDUBON

This activity book teaches kids ages 4 to 6 about how water connects every living thing. Each page builds curiosity and early science skills, nature observation, and investigation with on-the-page puzzles and outdoor learning activities. Nature-loving kids go on a Water Scavenger Hunt, try experiments, and discover all the parts of the Water Cycle.

Paper; 96 pages; 8¼ x 11¼
Full-color
\$12.99 US
ISBN 978-1-63586-780-0

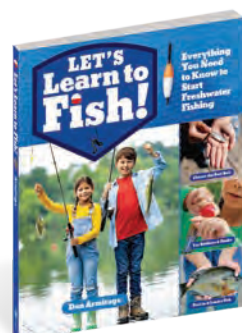

Let's Learn to Fish!

DAN ARMITAGE

Fishing guide Dan Armitage, of the Kids Fishing Fun Program, teaches kids ages 6 and up everything they need to catch the big one: the best beginner bait and tackle, key fishing skills such as rigging, casting, and reeling in fish, and tips on where to fish for crappies, bass, catfish, perch, trout, and more.

Paper; 128 pages; 7½ x 9½
Full-color
\$16.99 US
ISBN 978-1-63586-582-0



Rainbow Science

ARTEMIS ROEHRIG

Packed with 23 experiments and activities for kids ages 6 to 10, this book explores the fascinating science of rainbows and includes a pair of prism glasses so kids can see rainbows right before their eyes! Simple materials lists, and straightforward, age-appropriate experiment steps, are accompanied by scientific explanations for each activity.

Hardcover; 48 pages; 8 x 9
Full-color
\$16.99 US
ISBN 978-1-63586-617-9

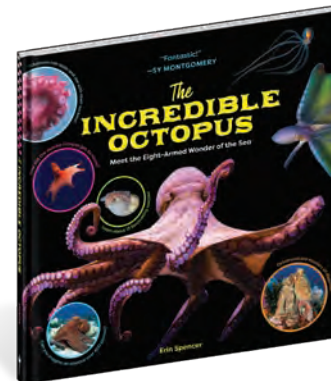

The Incredible Octopus

ERIN SPENCER

This fascinating book invites kids ages 7 and up to explore the behavior and intelligence of this remarkable creature of the deep. Readers are introduced to the biology of the octopus, from its 3 hearts and 9 brains to suction cups and how they work and learn all about what it's like to be an octopus.

Hardcover; 72 pages; 11 x 11
Full-color
\$19.99 US
ISBN 978-1-63586-628-5

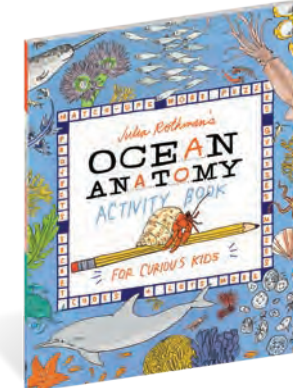

Julia Rothman's Ocean Anatomy Activity Book

JULIA ROTHMAN

Julia Rothman, bestselling author and illustrator of *Ocean Anatomy* presents a companion activity book for ages 8 and up, with creativity and learning activities, including matching challenges, mazes, ID and drawing exercises, nature journaling, and observational challenges. From penguins and whales to barnacles and jellyfish, kids will love joining Rothman's colorful ocean exploration.

Paper; 64 pages; 8 x 10
Full-color
\$12.99 US
ISBN 978-1-63586-778-7



How to Look at a Bird

CLARE WALKER LESLIE

Renowned naturalist/artist Clare Walker Leslie makes beginning birdwatching easy and fun with her illustrated guide to noticing and identifying the key distinguishing details of the most common birds seen at feeders, in nearby trees, and flying overhead, including the shapes of beaks, feathers, and talons, along with flight patterns and unique behaviors.

Paper; 144 pages; 5½ x 7
Full-color
\$18.99 US
ISBN 978-1-63586-649-0



Herbal Remedies for Sleep

MARIA NOËL GROVES

The author introduces readers to the top 15 herbs for reducing stress and encouraging a good night's sleep, along with recipes for using them in homemade formulas. The book includes three classes of herbs: those that have a general calming and relaxing effect; adaptogens, and sedative herbs.

Paper; 192 pages; 7 x 9
Full-color
\$19.99 US
ISBN 978-1-63586-774-9



Peruse Our Backlist

.....➔
See page 11, Image from:
The Garlic Companion, by Kristin Graves

BEST-SELLING AUTHOR EDWARD C. SMITH

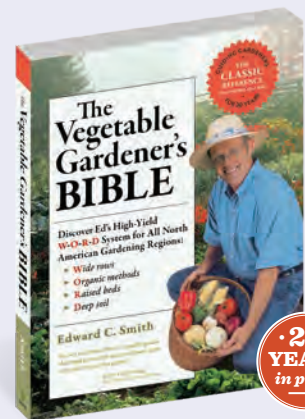

20 YEARS
in print

The Vegetable Gardener's Bible

This invaluable resource helps gardeners grow an abundance of vegetables and herbs following Ed Smith's time-tested system for high-yield harvests. Home food gardeners will find vegetable-specific information, an unwavering commitment to organic methods, solutions for small spaces, and tips for extending the season.

■ **650,000 COPIES IN PRINT**

Paper; 352 pages; 8½ x 10½
Full-color
\$24.95 US
ISBN 978-1-60342-475-2

Hardcover;
\$34.95 US
ISBN 978-1-60342-476-9

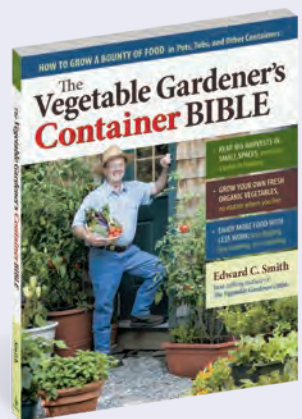

The Vegetable Gardener's Container Bible

Anyone can grow tomatoes on a patio or broccoli on a balcony with this comprehensive guide to selecting the right plants and containers, controlling pests without chemicals, planning small-space container gardens perfect for urban and suburban settings, and much more.

■ **139,000 COPIES IN PRINT**

Paper; 264 pages; 8½ x 10½
Full-color
\$22.95 US
ISBN 978-1-60342-975-7

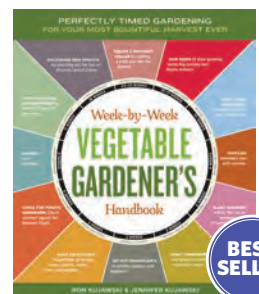

Week-by-Week Vegetable Gardener's Handbook

RON KUJAWSKI & JENNIFER KUJAWSKI

These detailed weekly to-do lists help readers learn exactly what to do in the garden—whether it's planting strawberries or checking for tomato hornworm—and exactly when to do it. Packed with valuable tips and information, this guide can be used in any gardening zone and includes space for customized record-keeping.

■ **133,000 COPIES IN PRINT**

Paper w/partially concealed wire-o;
200 pages; 7 x 9
Illustrations throughout
\$19.99 US
ISBN 978-1-60342-694-7



Starter Vegetable Gardens

BARBARA PLEASANT

With a new format and design, best-selling author Barbara Pleasant makes organic vegetable gardening easy, fun, and rewarding with detailed designs for 24 beginner-friendly gardens. From what to buy and where and when to plant, to how to care for each vegetable, Pleasant encourages readers to start small, grow the food they love, and expand their plant selection as their skills develop.

Paper; 232 pages; 8½ x 10½
Full-color
\$19.99 US
ISBN 978-1-63586-413-7

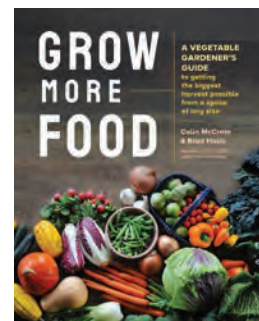

Grow More Food

COLIN MCCRATE & BRAD HALM

How productive can a small vegetable garden be? Co-authors McCrate and Halm, owners of the Seattle Urban Farm Company, help readers boost garden productivity by teaching how to plan carefully to maximize production in every bed, get the most out of every plant, scale-up systems to maximize efficiency, and expand the harvest season with succession planting, intercropping, and season extension.

Paper; 304 pages; 8½ x 10½
Full-color
\$24.95 US
ISBN 978-1-63586-409-0



Carrots Love Tomatoes

LOUISE RIOTTE

Plant parsley and asparagus together to have more of each. But keep broccoli and tomatoes apart or they won't thrive. This classic companion-gardening guide shows how to use the native attributes of plants to create a naturally bountiful garden.

■ **812,000 COPIES IN PRINT**

Paper; 224 pages; 6 x 9
Illustrations throughout
\$16.99 US
ISBN 978-1-58017-027-7



Roses Love Garlic

LOUISE RIOTTE

Companion planting makes use of the natural friendships between plants and has been practiced throughout most of agricultural history. This unique and amusing book provides information about dozens of flowering plants, including their companion-planting properties, medicinal uses, history, folklore, and more.

■ **213,000 COPIES IN PRINT**

Paper; 256 pages; 6 x 9
Illustrations throughout
\$16.99 US
ISBN 978-1-58017-028-4



Vegetable Garden Planner

LYNN BYCZYNSKI

This planner and journal for vegetable gardeners offers a quick-reference guide for each crop, expert gardening advice, and room to track growth and harvest of each vegetable from year to year. Organized alphabetically by vegetable, with several pages of note space for each crop so that readers can easily compare variety performance and flavor, weather trends, and pest pressure to those from previous years.

Paper; 208 pages; 7 x 10
Full-color
\$18.99 US
ISBN 978-1-63586-658-2



"Finally, a science-based book that addresses the 'companion planting' concept... Plant Partners is a fun and fascinating read."

—Joe Lamp'l, executive producer and host of *Growing a Greener World*

Plant Partners

JESSICA WALLISER

What makes a great pair? The practice of companion planting gets a science-based reboot with this first-ever research-based guide to how and why plant partnerships work. Through an enhanced understanding of how plants interact with and influence each other, this guide suggests specific plant combinations that improve soil health and weed control, decrease pest damage, and increase biodiversity. Readers who employ these scientifically tested plant partnerships will see real and measurable impacts in their garden.

■ American Horticultural Society Award Winner

Paper; 224 pages; 8 x 9
Full-color
\$24.99 US
ISBN 978-1-63586-133-4



The Vegetable Gardener's Book of Building Projects

EDITORS OF STOREY PUBLISHING

Simple-to-make projects include cold frames, compost bins, lawn chairs, and more. Each one features step-by-step instructions, detailed illustrations, a complete materials list, and a color photograph of the finished item.

■ **49,000 COPIES IN PRINT**

Paper; 152 pages; 8½ x 10½
Full-color
\$18.95 US
ISBN 978-1-60342-526-1

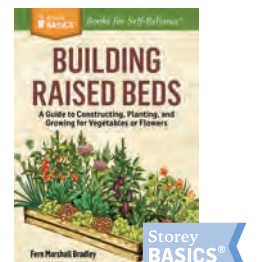

Building Raised Beds

FERN MARSHALL BRADLEY

Beginning gardeners and homeowners will enjoy this easy-access handbook on how to plan, build, and plant a simple raised bed. In just a weekend, using basic materials and minimal building skills, readers can set up a complete garden bed adapted for vegetables, flowers, or herbs.

Paper; 96 pages; 5 x 7
Illustrations throughout
\$8.95 US
ISBN 978-1-61212-616-6

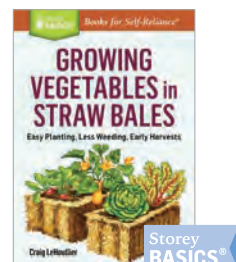

Growing Vegetables in Straw Bales

CRAIG LEHOULLIER

This innovative growing technique will appeal to anyone seeking a low-cost, low-maintenance way to grow a bounty of food in a small space. With just a bale of straw, some fertilizer, and a selection of favorite vegetable seeds, readers will learn how to set up, plant, and maintain healthy, hardy crops.

Paper; 96 pages; 5 x 7
Illustrations throughout
\$8.99 US
ISBN 978-1-61212-614-2

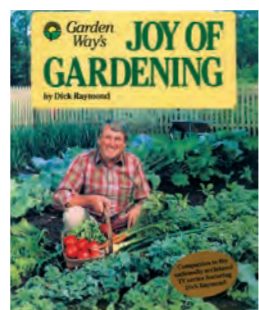

Joy of Gardening

DICK RAYMOND

This is the classic compendium of vegetable gardening wisdom. Illustrations, at-a-glance charts, and full-color photographs bring to life proven methods for raised beds, wide rows, and other techniques to yield a bigger harvest with less work.

■ **788,000 COPIES IN PRINT**

Paper; 384 pages; 8½ x 10½
Full-color
\$24.95 US
ISBN 978-0-88266-319-7



GrowVeg

BENEDICT VANHEEMS

The experts at GrowVeg.com feature 35 projects for any size garden there's truly something for everyone. Each project can be set up in a matter of a few hours, and step-by-step instructions with photos guide readers through each project.

Hardcover; 240 pages; 7 x 8
Full-color
\$19.95 US
ISBN 978-1-63586-292-8

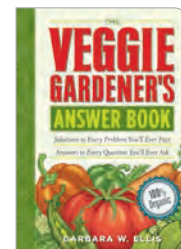

The Veggie Gardener's Answer Book

BARBARA W. ELLIS

This handy reference includes helpful, uncomplicated answers to questions on planning and planting a vegetable garden, improving soil, caring for crops, and organically controlling pests and diseases.

■ **69,000 COPIES IN PRINT**

Flexibind with paper spine; 432 pages;
4½ x 6½
Two-color
\$16.99 US
ISBN 978-1-60342-024-2



Gardening with Emma

EMMA BIGGS WITH STEVEN BIGGS

Written for kids by a kid, this guide by 13-year-old Emma Biggs shows young gardeners how to grow healthy food, raise the coolest plants, and cultivate fun! With her useful know-how and a range of original, practical, and entertaining advice, Biggs's playful handbook will ignite a passion for gardening in every kid who loves to be outdoors, digging in the dirt.

■ For ages 8–12
■ National Parenting Product Award

Paper; 144 pages; 8 x 10
Full-color
\$19.99 US
ISBN 978-1-61212-925-9



Epic Tomatoes

CRAIG LEHOULLIER

Every tomato gardener can now grow the best harvest ever. This practical and engaging guide offers everything tomato enthusiasts need to know about more than 200 varieties, from sowing seeds and transplanting, to cultivating and collecting seeds at the end of the season. A comprehensive section on pests and diseases also details how to keep tomatoes healthy and beautiful.

Paper; 256 pages; 8½ x 10½
Full-color
\$19.99 US
ISBN 978-1-61212-208-3

Hardcover;
\$30.00 US
ISBN 978-1-61212-464-3



“A great how-to book that will start the new gardener off the right way, using science and not Grandma’s gardening mythology.”

—Jeff Lowenfels, author of *Teaming with Microbes* and *Teaming with Nutrients*

Grow Your Soil!

DIANE MIESSLER

What you grow is only as good as the soil you grow it in. Create and maintain rich, dark, crumbly soil that’s teeming with life, using very few inputs and a no-till, no-fertilizer approach. Certified permaculture designer and lifelong gardener Diane Miessler presents the science of soil health in an engaging, entertaining voice geared for the backyard grower. She shares the techniques she has used—including cover crops, constant mulching, and a simple-but-supercharged recipe for compost tea—to transform her own landscape from a roadside dump for broken asphalt to a garden that stops traffic, starting from the ground up.

Paper; 176 pages; 6 x 9
Two-color
\$16.95 US
ISBN 978-1-63586-207-2



Backyard Foraging

ELLEN ZACHOS

Many edible plants can be found in backyards, lawns, and parks. Vacant lots host edibles such as sumac, purslane, and Japanese knotweed. Urban parks may offer up garlic mustard and ginkgo nuts. And lawns can be full of sheep sorrel, chickweed, dandelion, and pineapple weed. Invaluable safety tips and harvesting etiquette accompany these profiles of 65 edible weeds and ornamental plants, as well as a few mushrooms.

49,000 COPIES IN PRINT
Paper; 240 pages; 7 x 9
Full-color
\$16.99 US
ISBN 978-1-61212-009-6

ALSO AVAILABLE:
The Wildcrafted Cocktail, page 63



Don't Throw It, Grow It!

DEBORAH PETERSON & MILLICENT SELSAM

Pits, nuts, beans, seeds, and tubers can be coaxed into lush, vibrant houseplants that are both attractive and fascinating. Plant charts, step-by-step instructions, and illustrations show readers the path from kitchen scrap to beautiful plant.

44,000 COPIES IN PRINT
Paper; 160 pages; 6½ x 7½
Two-color
\$12.99 US
ISBN 978-1-60342-064-8

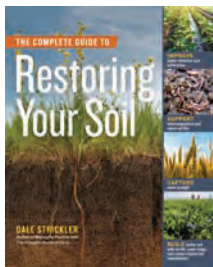

The Complete Guide to Restoring Your Soil

DALE STRICKLER

Dale Strickler is an expert on building healthy soil and restoring degraded soil, and in *The Complete Guide to Restoring Your Soil*, he presents a solid foundation in the science of healthy soil, along with proven methods of restoring depleted soil and agricultural practices from around the world that continue to build soil, rather than cause it to deteriorate.

Paper; 352 pages; 8 x 10
Full-color
\$24.95 US
ISBN 978-1-63586-224-9

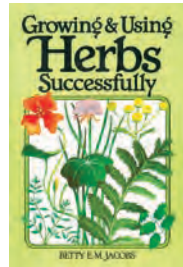

Growing & Using Herbs Successfully

BETTY E. M. JACOBS

With helpful and easy-to-understand language, this illustrated guide teaches readers how to plant, propagate, harvest, dry, freeze, store, and sell (both wholesale and retail) 64 of the most popular herbs.

182,000 COPIES IN PRINT
Paper; 240 pages; 6 x 9
Illustrations throughout
\$14.95 US
ISBN 978-0-88266-249-7

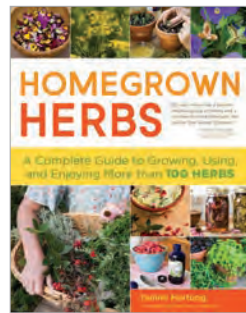

Homegrown Herbs

TAMMI HARTUNG

This primer shows gardeners how to plant, grow, harvest, and use more than 100 popular herbs. It covers everything from seed selection to drying, plus uses in the kitchen and home pharmacy, crafting, and body care. Whether they want to grow a few herbs in containers or have an extensive herb garden, readers will see how easy it is to bring more beauty, flavor, and health to everyday life.

53,000 COPIES IN PRINT
Paper; 256 pages; 8½ x 10½
Full-color
\$22.99 US
ISBN 978-1-60342-703-6

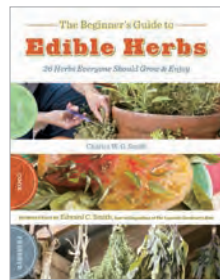

The Beginner's Guide to Edible Herbs

CHARLES W. G. SMITH

Simple instructions, tempting recipes, and beautiful photographs will inspire readers to grow, harvest, preserve, and cook with 26 of the most popular kitchen herbs, including basil, cilantro, dill, fennel, garlic, lavender, oregano, parsley, sage, tarragon, and more. This is a great gift for any herb lover!

Paper; 152 pages; 7 x 9
Full-color
\$14.95 US
ISBN 978-1-60342-528-5

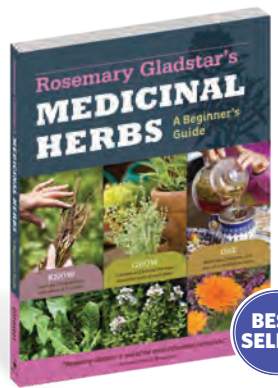

“One of the most-trusted and well-respected herbalists of our time... this book is a must-read for every budding herbalist.”

— Taste for Life Magazine

Rosemary Gladstar's Medicinal Herbs: A Beginner's Guide

More than 100 easy-to-follow and effective recipes for teas, salves, tinctures, oils, syrups, and pills help naturally fortify against common upsets and ailments. Craft a soothing aloe lotion after an encounter with poison ivy, make a dandelion-burdock tincture to fix sluggish digestion, and brew some lavender-lemon balm tea to ease a stressful day. This introductory guide teaches a new generation of gardeners and natural health enthusiasts how easy it can be to make herbal remedies for life's common ailments.

628,000 COPIES IN PRINT
Paper; 224 pages; 7 x 9
Full-color
\$16.99 US
ISBN 978-1-61212-005-8

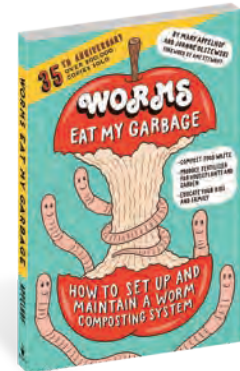

“For worm pioneers, this is the classic work on the subject.”

— Anne Raver, *New York Times*

Worms Eat My Garbage, 35th Anniversary Edition

MARY APPELHOF & JOANNE OLSZEWSKI

The best-selling guide to the practice of vermicomposting—using worms to recycle food waste into nutrient-rich fertilizer for houseplants or gardens—is now fully updated and redesigned. From building or purchasing a bin (readily available at garden supply stores) to maintaining the worms and harvesting finished compost, the new edition features the same friendly tone of the original, with up-to-date information on the entire process.

Paper; 192 pages; 6 x 9
Illustrations throughout
\$15.99 US
ISBN 978-1-61212-947-1

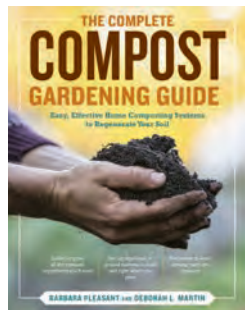

The Complete Compost Gardening Guide

BARBARA PLEASANT & DEBORAH L. MARTIN

Keeping nourishing compost heaps right in the garden means less digging, weeding, and mulching—plus no more backbreaking slogs from the compost bin. The authors identify the plants that benefit most from compost and explain how the elements of a composted garden work together.

94,000 COPIES IN PRINT
Paper; 320 pages; 8½ x 10½
Full-color
\$24.99 US
ISBN 978-1-58017-702-3



Let It Rot!

STU CAMPBELL

Generations of gardeners have learned how to recycle waste to create soil-nourishing compost using this classic guide, with its friendly advice for starting a composting system, building bins, maintaining a healthy heap, and putting finished compost to use.

391,000 COPIES IN PRINT
Paper; 160 pages; 6 x 9
Illustrations throughout
\$14.99 US
ISBN 978-1-58017-023-9

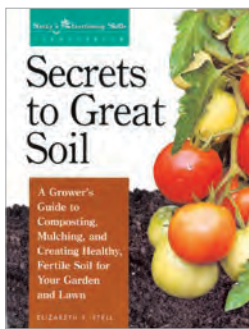

Secrets to Great Soil

ELIZABETH P. STELL

More than 300 detailed illustrations and dozens of at-a-glance charts show gardeners how to solve all their soil problems and build fertile, productive soil throughout the year. Readers learn the basics of soil pH and nutrients, quick composting methods, and tips for customizing soil for a variety of vegetables, flowers, fruits, trees, and shrubs.

44,000 COPIES IN PRINT
Paper; 224 pages; 8½ x 11
Illustrations throughout
\$19.95 US
ISBN 978-1-58017-008-6



Gardening with Biochar

JEFF COX

Organic gardeners have embraced bioactivated charcoal—called biochar—for its outstanding abilities to enrich soil and improve plant growth, and its capacity to sequester carbon in the ground. This highly accessible handbook provides detailed instructions for making biochar from wood or other kinds of plant material, along with specific guidelines for using it effectively in the home garden.

Paper; 128 pages; 7 x 9
Full-color
\$18.95 US
ISBN 978-1-61212-955-6



Cold-Climate Gardening

LEWIS HILL

Here is invaluable information for northern gardeners on how to grow food, landscape, protect vulnerable plantings, warm up the soil earlier, and choose appropriate species. This book will also be useful to gardeners in microclimates (such as deep valleys) or those who want to extend the gardening season in any climate.

44,000 COPIES IN PRINT
Paper; 320 pages; 6 x 9
Photographs and illustrations throughout
\$16.95 US
ISBN 978-0-88266-441-5



Herbal Tea Gardens

MARIETTA MARSHALL MARCIN

A gardening bible for the tea lover, this book contains full instructions for growing herbs for tea and includes 22 illustrated plans for customized tea gardens. More than 100 recipes for blending and brewing the herbs in healthful and delicious combinations ensure that readers will keep turning to this book long after the harvest is in.

Paper; 192 pages; 8 x 8
Illustrations throughout
\$18.99 US
ISBN 978-1-58017-106-9

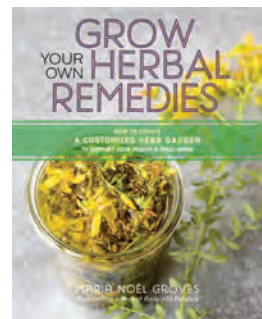

Grow Your Own Herbal Remedies

MARIA NOËL GROVES

Whether seeking headache or stress relief, immune support, or a daily tonic, readers will learn the three to six herbs that offer the most effective treatment for their condition. It includes over 20 garden plans emphasizing safe, effective, easy-to-grow herbs, along with simple recipes tailored to address common health considerations.

Paper; 336 pages; 8 x 10
Full-color
\$24.95 US
ISBN 978-1-63586-013-9

ALSO AVAILABLE:
Body into Balance, page 39

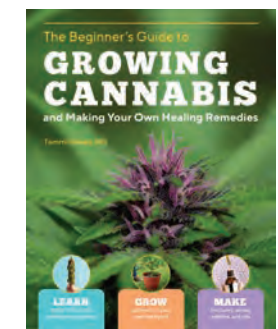

The Beginner's Guide to Growing Cannabis

TAMMI SWEET, MS

This friendly guide teaches how to grow healthy cannabis plants outdoors for personal use, and make your own customized remedies for addressing a range of common ailments and chronic conditions. With step-by-step photography, author Tammi Sweet, shows the growing phases of the plant and details techniques for planting, caring for, harvesting, drying, and curing the plant.

Paper; 144 pages; 7 x 9
Full-color
\$19.99 US
ISBN 978-1-63586-558-5

THE XERCES SOCIETY

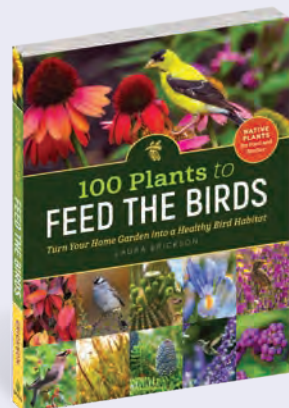

100 Plants to Feed the Birds

This guide offers in-depth planting and care information for 100 native plant species that feed and shelter birds all year long, including during breeding and migrating periods. Some of these plants can be added to a garden, some are wild plants to avoid weeding, and some are trees to plant. Color photographs and range maps give visual guidance to choose the right plants for any location in North America.

Paper; 256 pages; 7 x 9
Full-color
\$16.99 US
ISBN 978-1-63586-438-0

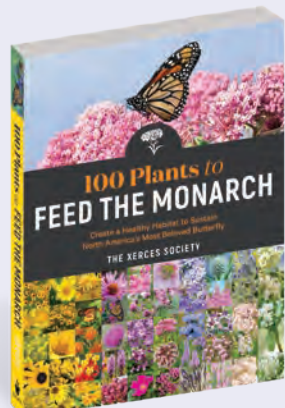

100 Plants to Feed the Monarch

Gorgeous photographs, plus illustrations, maps, and garden plans, provide an in-depth portrait of the monarch butterfly, and detailed instructions for creating monarch-friendly landscapes. At-a-glance profiles identify plant species that provide nourishment throughout the monarch's life cycle. Plants range from dozens of milkweed species—the only food of monarch caterpillars—to flowering plants, shrubs, and trees.

Paper; 288 pages; 6 x 8
Full-color
\$16.95 US
ISBN 978-1-63586-273-7

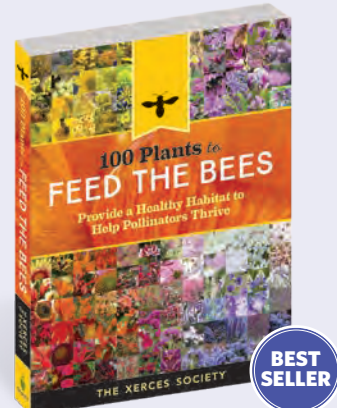

100 Plants to Feed the Bees

The Xerces Society for Invertebrate Conservation offers browsable profiles of 100 common flowers, herbs, shrubs, and trees that support bees, butterflies, moths, and hummingbirds. The recommendations are simple: pick the right plants for pollinators, protect them from pesticides, and provide abundant blooms throughout the growing season by mixing perennials with herbs and annuals.

■ Garden Writers Association Silver Award of Achievement

■ **66,000 COPIES IN PRINT**

Paper; 240 pages; 6 x 8
Full-color
\$18.99 US
ISBN 978-1-61212-701-9



ALSO AVAILABLE:
Farming with Native Beneficial Insects, page 107



We Garden Together

JANE HIRSCHI

This introductory garden book features hands-on planting and growing activities that can be done in a small yard, classroom, or community garden. Written by the staff of City Sprouts, each activity—encourages kids to roll up their sleeves and learn about seeds, planting, and gardening.

Paper; 48 pages; 8 x 9
Full-color
\$12.99 US
ISBN 978-1-63586-545-5
Ages 3-6



The Garden Maker's Book of Wonder

ALLISON VALLIN KOSTOVICK

Popular gardening lifestyle influencer Allison Vallin Kostovick (Finch + Folly) invites fans of cottagecore, gardening, and nature-based living to share her journey as she crafts, cooks, and creates. Drawing on decades of gardening experience, *The Garden Maker's Book of Wonder* offers sage advice on growing bountiful harvests of favorite vegetables, herbs, and flowers. All levels of gardeners, from dreamers to the experienced, will delight in the variety and creativity of Kostovick's projects, activities, and recipes for enjoying the magic and whimsy of the natural world—no matter what season.

Hardcover; 256 pages; 8½ x 11
Full-color
\$30.00 US
ISBN 978-1-6358653-1-8

"Gives lavender lovers a great starting point to selecting, growing, and using this popular herb."
— *The American Gardener*



The Lavender Companion

TERRY BARLIN VESCI AND JESSICA DUNHAM

This lavishly photographed celebration of the beloved herb, written by an acclaimed lavender farmer and cooking instructor, is brimming over with inspiration and ideas for bringing the fragrance and flavor of lavender into daily life. The book profiles the most popular lavender varieties and their recommended uses, along with the history, lore, and traditional medicinal uses. More than 40 recipes showcase lavender in delicious dishes from the kitchen as well as homemade craft and body products. Tips for success with lavender in the garden complete this perfect gift for every lavender lover.

Hardcover; 176 pages; 7 x 9
Full-color
\$26.00 US
ISBN 978-1-63586-684-1

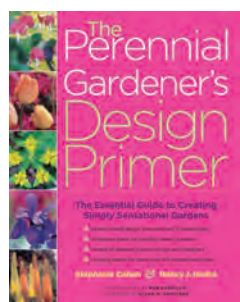

The Perennial Gardener's Design Primer

STEPHANIE COHEN & NANCY J. ONDRA

This primer explains how to choose perennials that combine well and suit a specific site, offering down-to-earth design solutions for 20 specific types of gardens, including a low-maintenance garden, a more complex container garden, and a cottage garden.

■ Garden Writers Association Silver Award of Achievement

Paper; 320 pages; 8½ x 10½
Full-color
\$27.95 US
ISBN 978-1-58017-543-2

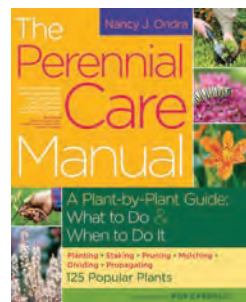

The Perennial Care Manual

NANCY J. ONDRA

Thorough instructions on how to care for more than 125 popular perennials ensure a healthy garden for all growers.

Paper; 384 pages; 8½ x 10½
Full-color
\$29.95 US
ISBN 978-1-60342-150-8



Hardy Succulents

GWEN MOORE KELAIDIS
PHOTOGRAPHY BY SAXON HOLT

From agaves to ice plants, hardy succulents add a touch of the unexpected to nondesert gardens. This resource shows readers how to grow succulents in any North American hardiness zone.

■ American Horticultural Society Book Award

Paper with flaps; 160 pages; 9½ x 9½
Full-color
\$19.95 US
ISBN 978-1-58017-700-9

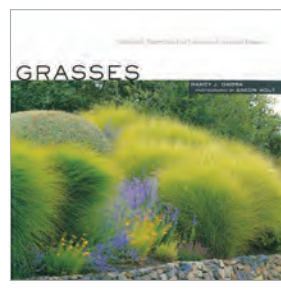

Grasses

NANCY J. ONDRA
PHOTOGRAPHY BY SAXON HOLT

Ornamental grasses provide diversity in garden designs, stabilize soil, and conserve water. These illustrated plans for 24 gardens show how to use dozens of stunning grass varieties.

■ **115,000 COPIES IN PRINT**

Paper with flaps; 144 pages; 9½ x 9½
Full-color
\$19.95 US
ISBN 978-1-58017-423-7



Design-Your-Garden Toolkit

MICHELLE GERVAIS

Before picking up the trowel, pick up the stickers! This interactive package includes 150 reusable stickers that feature plant varieties with visual appeal, a foldout design board, and expert guidance for creating an eye-catching garden layout. Growers of all levels will find the tools they need to execute their vision.

Paper with 150 reusable vinyl stickers and laminated fold-out design board; 80 pages; 8 x 10
Full-color
\$19.95 US
ISBN 978-1-61212-922-8

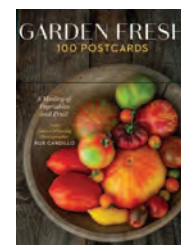

Garden Fresh Postcards

ROB CARDILLO

A vibrant collection of 100 postcards features 50 different images of vegetables, fruits, and herbs from award-winning garden photographer Rob Cardillo. Up-close shots capture the distinctive shapes and features of heirloom varieties. The back of each card features a short description of each variety. A flip-top box completes this perfect gift for food lovers and gardeners.

Cards; 100 postcards in a flip top box; 4½ x 6½
Full-color
\$19.95 US
ISBN 978-1-63586-586-8



Garden Flowers Postcards

ROB CARDILLO

A beautiful assortment of 100 postcards featuring 50 images of stunning garden flowers from award-winning garden photographer Rob Cardillo. From the explosive heads of pink peonies to delicate sweet peas, majestic hollyhocks, and fields of black-eyed Susan, every picture celebrates the exuberant joy of the garden. A flip-top box completes the giftable package.

Cards; 100 postcards in a flip top box; 4½ x 6½
Full-color
\$19.99 US
ISBN 978-1-63586-623-0



Mini Meadows

MIKE LIZOTTE

Meadows don't have to be big to be beautiful and beneficial. This inspiring handbook guides gardeners of all levels in creating an informal patch of colorful flowers suited to their climate, soil, space, and growing goals. Suggested seeds, maintenance tips, and soil evaluation strategies ensure success, whether readers are enhancing a hellstrip, filling a boggy spot, or establishing a haven for pollinators.

Paper; 152 pages; 8 x 8½
Full-color
\$16.99 US
ISBN 978-1-61212-835-1

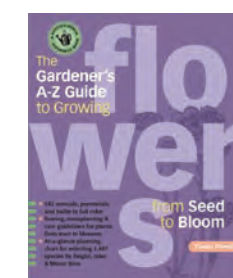

The Gardener's A-Z Guide to Growing Flowers from Seed to Bloom

EILEEN POWELL

This encyclopedia of 576 annuals, perennials, and bulbs—with information on sowing, transplanting, bloom time, propagation, and general care—features a full-color flower gallery and a design planner.

Paper; 528 pages; 7¾ x 9¾
Two-color with 64-page full-color plant guide
\$29.95 US
ISBN 978-1-58017-517-3



The Flower Gardener's Bible

LEWIS & NANCY HILL

This comprehensive guide includes plans for 25 beautiful theme gardens and a photographic encyclopedia with specific advice on growing more than 400 species of flowers.

■ **90,000 COPIES IN PRINT**
Paper; 384 pages; 8½ x 10½
Full-color
\$29.95 US / \$44.95 CAD / UK: NA
ISBN 978-1-58017-462-6; No. 67462



“An extremely well-written and organized reference for those interested in taking more control of the seeds they plant.”

— William James Lamont Jr., Professor, Penn State University & Past President of the American Society for Horticultural Science

The Complete Guide to Saving Seeds

ROBERT GOUGH & CHERYL MOORE-GOUGH

This comprehensive guide shows exactly how to collect, save, and cultivate the seeds from more than 300 vegetables, herbs, fruits, flowers, trees, and shrubs. Easy-to-follow instructions take gardeners through every step of the process. Authors Robert Gough and Cheryl Moore-Gough explain basic plant biology, proper seed storage and successful propagation. Gardeners of any experience level will find all the information they need to preserve genetic diversity, cut costs, and extend the life of their favorite plants to the next generation and beyond.

Paper; 320 pages; 8½ x 10½
Full-color
\$24.99 US
ISBN 978-1-60342-574-2

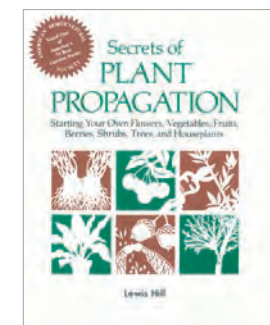

Secrets of Plant Propagation

LEWIS HILL

Readers can grow plants from seed and learn how to start shrubs and trees with these clearly explained grafting techniques. The results will be bountiful, healthy plants and great-tasting fruits and vegetables.

■ **136,000 COPIES IN PRINT**
Paper; 176 pages; 8½ x 11
Illustrations throughout
\$19.99 US
ISBN 978-0-88266-370-8

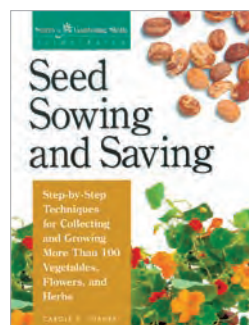

Seed Sowing and Saving

CAROLE B. TURNER

In-depth explanations teach readers when to harvest the seeds of more than 100 vegetables, herbs, and flowers, as well as how to dry, store, and test them for viability for the next growing season.

■ **50,000 COPIES IN PRINT**
Paper; 224 pages; 8½ x 11
Illustrations throughout
\$22.99 US
ISBN 978-1-58017-001-7

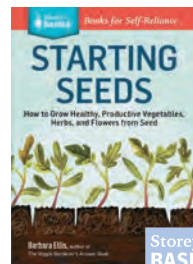

Starting Seeds

BARBARA ELLIS

Gardeners of any experience level can get a jump on the growing season with this concise, straightforward guide. Practical advice teaches readers foolproof starting techniques for a variety of vegetables, herbs, and flowers.

Paper; 128 pages; 5 x 7
Illustrations throughout
\$8.99 US
ISBN 978-1-61212-105-5

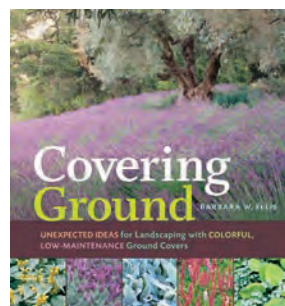

Covering Ground

BARBARA W. ELLIS

Ground covers are a beautiful way to bring variety, texture, and durability to open sweeps of lawn. A vibrant new palette of unexpected plant choices, along with hardworking design and planting advice, give gardeners the know-how to create striking, low-maintenance alternatives to traditional lawns.

Paper; 224 pages; 9¼ x 10
Full-color
\$24.95 US
ISBN 978-1-58017-665-1



Greywater, Green Landscape

LAURA ALLEN

This must-have manual guides homeowners and gardeners through planning and installing a variety of greywater systems, including laundry-to-landscape, to capture and recycle wastewater from sinks, showers, and washing machines. Readers will learn to estimate flow rate and pinpoint the areas or specific plants in their landscape that will reap the greatest benefit from redirected wastewater.

Paper; 200 pages; 7 x 9
Full-color
\$16.95 US
ISBN 978-1-61212-839-9



Saving Seeds

MARC ROGERS

Saving seeds is an economical and time-tested way for gardeners to grow their favorite plants again and again. Accessible information provides all the necessary details to learn how to select, harvest, and store seeds from more than 100 flowers and vegetables commonly grown in home gardens.

■ **75,000 COPIES IN PRINT**
Paper; 192 pages; 6 x 9
Illustrations throughout
\$14.95 US
ISBN 978-0-88266-634-1

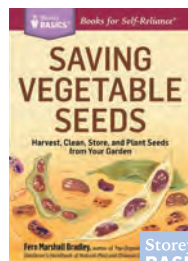

Saving Vegetable Seeds

FERN MARSHALL BRADLEY

Once gardeners learn to start their plants from seed, they'll want to know how to harvest and save seeds to use the following season. Helpful illustrations and tips guide readers through seed saving for 20 of the most common vegetables gardeners grow, including beans, carrots, peppers, and tomatoes.

Paper; 96 pages; 5 x 7
Illustrations throughout
\$8.99 US
ISBN 978-1-61212-363-9

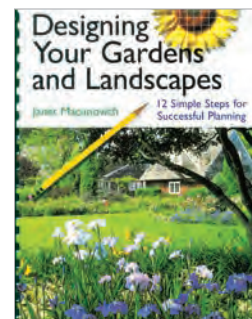

Designing Your Gardens and Landscapes

JANET MACUNOVICH

Appropriate for any region, this practical 12-step approach to home landscape design focuses on the individual preferences, natural restrictions, and climatic concerns of the landscaper.

■ **76,000 COPIES IN PRINT**
Paper with comb-binding; 176 pages; 8½ x 10½
Illustrations throughout
\$19.95 US
ISBN 978-1-58017-315-5



Deerproofing Your Yard & Garden

RHONDA MASSINGHAM HART

Plants can be protected from deer damage with innovative fencing, home-made or commercial repellents, or simply plants that deer hate, as this classic volume on deer-proofing explains.

■ **130,000 COPIES IN PRINT**
Paper; 208 pages; 6 x 9
Illustrations throughout
\$16.99 US
ISBN 978-1-58017-585-2



The Organic Lawn Care Manual

PAUL TUKEY

Growing a healthy, organic lawn begins with well-treated soil and planting cultivars suited for the region's climate. This guide shows how easy and economical it can be to maintain a beautiful chemical-free yard.

■ **46,000 COPIES IN PRINT**
Paper; 272 pages; 8½ x 10½
Full-color
\$22.95 US
ISBN 978-1-58017-649-1

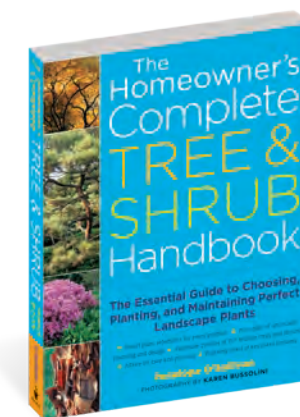

“A LANDSCAPER'S ENCYCLOPEDIA. Here's the big, thick book on everything you want to know about trees and shrubs.”

— St. Petersburg Times

The Homeowner's Complete Tree & Shrub Handbook

PENELOPE O'SULLIVAN

This comprehensive guide explains the principles and practicalities of bringing magnificent woody plants to every landscape. The book includes profiles of 357 reliable trees and shrubs with information on availability, size, hardiness, and special characteristics. Penelope O'Sullivan shows how to use these plants to add structure and texture to any outdoor space. Create a vibrant landscape full of springtime blossoms, summer shade and fruits, autumn foliage, and winter evergreens.

Paper; 416 pages; 8½ x 10½
Full-color
\$29.95 US
ISBN 978-1-58017-570-8

“The sustainable techniques outlined here produce better plants, higher yields, fewer weeds, and healthier soil. They are time tested, easy, practical, and cost effective. You can put the information in this book to use right away.”

— Mike Evans, Founder, Tree of Life Nursery

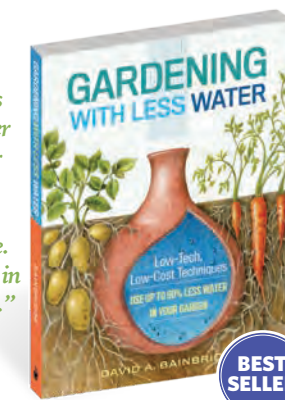

Gardening with Less Water

DAVID A. BAINBRIDGE

From terra-cotta pots to recycled plastic bottles, these low-tech, low-cost, water-saving irrigation systems are easily installed in gardens and containers and are up to 10 times more efficient than other irrigation methods. Full-color photographs and illustrated step-by-step instructions show how to assemble and use these systems in the home landscape.

■ Silver Nautilus Award
Paper; 128 pages; 6 x 8
Full-color
\$14.99 US
ISBN 978-1-61212-582-4

BEST SELLER



"An approachable, elegantly illustrated guide to the ecological hub that is milkweed."

— Benjamin Vogt, author of *Prairie Up: An Introduction to Natural Garden Design* and *A New Garden Ethic*

The Milkweed Lands

ERIC LEE-MÄDER

Ecologist Eric Lee-Mäder and noted botanical artist Beverly Duncan have teamed up to create this unique exploration of the complex ecosystem that is supported by the remarkable milkweed plant, often overlooked or dismissed as a roadside weed. With stunning, up-close illustrations and engaging text, they trace every stage of the plant's changes and evolutions throughout the seasons, including germination, growth, flowering, and seed development. Simultaneously, they chronicle the lives of the many creatures whose lives are intertwined with the milkweed: monarch butterflies; soldier and queen butterflies; milkweed tussock moths; large and small milkweed bugs; milkweed weevils; bumble bees; goldfinches; and more.

■ NATIONAL OUTDOOR BOOK AWARD WINNER

Hardcover; 120 pages; 7¼ x 10¼
Full-color
\$20.00 US
ISBN 978-1-63586-436-6



"Because of the Martins, I now grow my own oranges, lemons, grapefruits, limes, carambolas, coffee beans, calamondins, papayas, vanilla, passion fruit, figs, and guavas. I rely on them for advice about the care of these extraordinary plants."

— Martha Stewart

Edible Houseplants

LAURELYNN MARTIN AND BYRON E. MARTIN

Laurelynn and Byron Martin, owners of Logee's Plants for Home & Garden, are nationally renowned for their expertise in growing fruit-bearing and tropical plants indoors. Their colorful guide features photos and complete care guidelines for 46 food-bearing plants, includes lemons, limes, grapefruit, cherries, olives, passion fruit, papaya, and much more. Fresh, fragrant, and flavorful, *Edible Houseplants* expands the fun and pleasure of growing indoor plants.

Paper; 160 pages; 9½ x 9½
Full-color
\$19.99 US
ISBN 978-1-63586-678-0



Plant Pets

BEATRICE BOGGS ALLEN AND BELLE BOGGS

Maybe every kid can't have an animal pet—but everyone can have a plant pet! That's the message of ten-year-old author and houseplant enthusiast Beatrice (Bea) Boggs Allen. In this friendly book written specially for kids, Bea tells all about the easiest, most fun, and affordable plants that can be grown indoors in pots. She shares her first-hand tips on caring for each plant, along with descriptions of each one's unique attributes. Kids ages 7 and up will love Bea's ideas for activities they can do to enjoy these amazing plants and share them with friends and family.

Hardcover; 72 pages; 9 x 10
Full-color
\$16.99 US
ISBN 978-1-63586-767-1
Ages 7-10

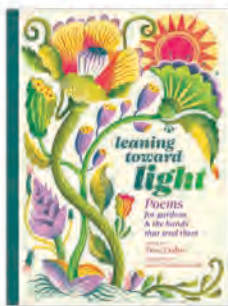

Leaning Toward Light

EDITED BY TESS TAYLOR

In this poetry anthology, acclaimed poet Tess Taylor brings together a diverse range of contemporary voices to offer poems that celebrate that joyful connection to the natural world. Well-known contemporary writers, as well as some of poetry's exciting rising stars, contribute to this collection including Ross Gay, Jericho Brown, Ada Limón, Danusha Laméris, and James Crews. A foreword by Airree Nezhukumatahil, along with original illustrations by Melissa Castrillon, and a ribbon bookmark complete this stunning gift format.

Hardcover; 200 pages; 6¼ x 8¼
Full-color
\$22.00 US
ISBN 978-1-63586-580-6



The Complete Houseplant Survival Manual

BARBARA PLEASANT

This guide shows readers how to care for exciting imports, dozens of long-flowering varieties, and hardier cultivars of old favorites. Profiles of 160 flowering and foliage houseplants cover troubleshooting, care, pruning, repotting, and propagating, and the A-to-Z primer on houseplant health is an invaluable resource.

Paper; 384 pages; 7½ x 10½
Full-color
\$24.99 US
ISBN 978-1-63586-660-5



House Jungle

ANNIE DORNAN-SMITH

Presented with a decorator's eye, this joyful, illustrated introduction to houseplants shows how to prepare the perfect container and select plants based on their needs and their looks. Whether the home style calls for large architectural plants, hanging baskets, or cacti and succulents, readers will find tried-and-true options to ensure success. No gardening experience necessary!

Paper with flaps; 104 pages; 6½ x 6½
Full-color
\$12.95 US
ISBN 978-1-61212-944-0



Growing Healthy Houseplants

ELLEN ZACHOS

Beginner houseplant owners who want to keep their plants thriving will learn what plants need in terms of location, sunlight, water, and fertilizer; when plants should be repotted; how to prune; how to keep plants clean and free of pests; and basic propagation.

Paper; 128 pages; 5 x 7
Illustrations throughout
\$8.95 US
ISBN 978-1-61212-440-7

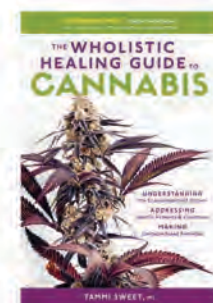

The Wholistic Healing Guide to Cannabis

TAMMI SWEET, MS

Combining scientific research with an appreciation for traditional uses of cannabis, herbalist Tammi Sweet offers a full perspective on the attributes of the cannabis plant and the physiology of the endocannabinoid system in the human body, and provides detailed instructions for making cannabis remedies at home.

Paper; 272 pages; 6 x 9
Two-color with 16-page full-color insert
\$24.95 US
ISBN 978-1-63586-137-2

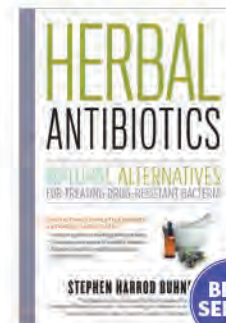

Herbal Antibiotics, 2nd Edition

STEPHEN HARROD BUHNER

As antibiotic-resistant infections become increasingly common, this bestseller has become an indispensable reference for sound information on herbal alternatives to standard antibiotics. In-depth profiles of 30 valuable herbs examine each plant's antibiotic properties, methods for collection and preparation, dosages, contraindications, and potential side effects.

■ 165,000 COPIES IN PRINT
Paper; 480 pages; 6 x 9
Two-color
\$25.99 US
ISBN 978-1-60342-987-0



Herbal Antivirals, 2nd Edition

STEPHEN HARROD BUHNER

With new strains of viruses emerging, more people are looking for alternative ways to boost immunity and fight infection. This comprehensive manual addresses the best herbal protocols for strengthening the immune system and treating flu, COVID-19, encephalitis, SARS, Ebola, dengue fever, and more.

Paper; 480 pages; 6 x 9
Two-color
\$24.95 US
ISBN 978-1-63586-417-5

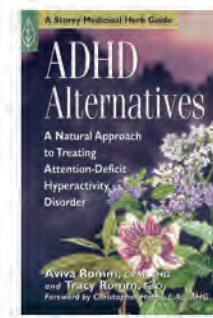

ADHD Alternatives

AVIVA & TRACY ROMM

Many parents and educators want to take a holistic, natural, and effective approach to the problems of attention, impulsivity, and hyperactivity. This thoughtful and inspiring book offers advice on addressing a child's unique needs through nutrition, herbal medicine, and understanding parenting.

Paper; 160 pages; 5½ x 8½
Photographs and illustrations throughout
\$14.99 US
ISBN 978-1-58017-248-6

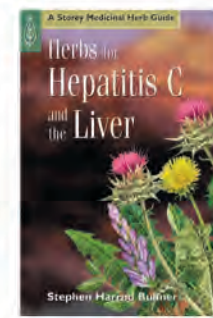

Herbs for Hepatitis C and the Liver

STEPHEN HARROD BUHNER

After an in-depth overview of liver-related diseases, this helpful reference offers practical advice for protecting the liver and strengthening the immune system with medicinal herbal formulas plus lifestyle and diet changes.

Paper; 160 pages; 5½ x 8½
Photographs and illustrations throughout
\$12.95 US
ISBN 978-1-58017-255-4



The Natural First Aid Handbook, 2nd Edition

BRIGITTE MARS

Hundreds of lifesaving techniques, effective responses to a wide range of ailments, common sense tips, and time-tested herbal remedies fill this quick-reference guide. Readers will also learn when to seek professional medical help and what to do while awaiting the arrival of emergency personnel.

■ 42,000 COPIES IN PRINT
Paper; 192 pages; 5 x 7
Illustrations throughout
\$14.99 US
ISBN 978-1-61212-857-3

"Well organized, user friendly, and extremely relevant to clinical therapy, it's a must have for patients and physicians alike."

— Dr. Jillian Stansbury, ND, Director of Battle Ground Healing Arts and BG Healing Arts Apothecary



Holistic Cancer Care

CHANCHAL CABRERA

Chanchal Cabrera, a medical herbalist with a specialty in integrative oncology, provides an in-depth guide to practical, solution-focused strategies for using herbal medicines and other natural therapies to complement conventional cancer treatment, help patients remain strong during treatment, and support their return to full health following treatment. Drawing from decades of clinical experience helping patients recover from cancer, Cabrera provides a wealth of safe, well-researched information, including specific herbal formulas, important discussions about dosing and safety, detox protocols, recommendations for nutritional supplements, and simple recipes for nourishing meals.

Paper; 576 pages; 6 x 9
Illustrations throughout
\$29.99 US
ISBN 978-1-63586-373-4

Hardcover; \$40.00 US
ISBN 978-1-63586-648-3

BEST-SELLING AUTHOR ROSEMARY GLADSTAR

MORE THAN 1 MILLION COPIES IN PRINT



“Both inspiring and practical. Absolutely brilliant to be empowered to offer healing to our children right in our own kitchen!”

—Michaël Friedman, ND, founder of the Association for the Advancement of Restorative Medicine

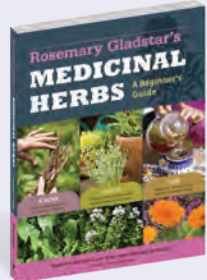

Rosemary Gladstar's Medicinal Herbs: A Beginner's Guide

For a new generation of gardeners and natural health enthusiasts, here is a fresh introduction to growing and using 33 healing herbs, including aloe vera, chamomile, lavender, and turmeric. More than 100 easy-to-follow and effective recipes for teas, salves, tinctures, oils, syrups, and pills help naturally fortify against common upsets and ailments.

■ 628,000 COPIES IN PRINT

Paper; 224 pages; 7 x 9
Full-color
\$16.99 US
ISBN 978-1-61212-005-8



Rosemary Gladstar's Herbal Recipes for Vibrant Health

This comprehensive collection of homemade herbal recipes offers a potent prescription for energy and good health at every stage of life. An A-to-Z guide to more than 90 common plants is accompanied by 175 simple, safe, and effective herbal formulas for treating everyday ailments and boosting beauty and vitality.

■ 260,000 COPIES IN PRINT

Paper; 408 pages; 7 1/4 x 7 1/4
Full-color
\$18.99 US
ISBN 978-1-60342-078-5



Fire Cider!

In this lively celebration of a beloved and versatile folk remedy, more than 70 herbal enthusiasts contribute 101 recipes ranging from Black Currant Fire Cider to Triple Goddess Vinegar, Fire Cider Dark Moonshine, and Bloody Mary Fire Cider.

Paper; 204 pages; 7 x 9
Full-color
\$17.99 US
ISBN 978-1-63586-180-8



Spice Apothecary

Spices not only add flavor, but are good for you too. Herbalist and nutritionist Bevin Clare explores how 19 common culinary spices can be used to achieve optimal health, and offers recipes for blends formulated to address health goals, from bolstering the immune system to supporting kidney health.

Paper; 176 pages; 6 1/2 x 8 1/2
Full-color
\$18.95 US
ISBN 978-1-63586-083-2



Sweet Remedies

The synergy between raw honey and medicinal herbs amplifies the healing properties of both. Formulations for honey spreads (called electuaries), infusions, and oxymels address common ailments and support overall wellness for people of all ages. Additional recipes offer creative ways to get a dose of healing into food.

Paper; 224 pages; 6 1/2 x 8 1/2
Full-color
\$19.95 US
ISBN 978-1-61212-992-1



Recipes from the Herbalist's Kitchen

Food is medicine, and this unique cookbook reveals the healing properties of favorite culinary herbs—including dill, sage, basil, and mint. Insightful plant profiles accompany irresistible recipes for snacks, entrées, drinks, and desserts that meet the body's needs for comfort, nourishment, energy, and support through seasonal changes.

- IACP Award Finalist
- Gold Foreword INDIES Award
- Silver Nautilus Award

Hardcover; 312 pages; 8 x 10
Full-color
\$30.00 US
ISBN 978-1-61212-690-6

“As a fellow Green Beret, survivalist, and medic, I can say without a shadow of a doubt: THIS IS THE BEST BOOK OUT THERE ON THE SUBJECT.”

—Mykel Hawke, retired Special Forces Officer, Green Beret medic, and creator and star of Discovery Channel's *Man Woman Wild*

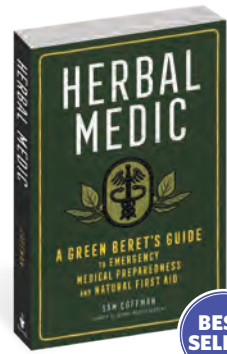

BEST SELLER

Herbal Medic

SAM COFFMAN

Disasters and serious accidents can happen any time, anywhere. *Herbal Medic* equips readers with skills they can use when they're without immediate access to professional medical help or resources. Coffman's background as a Green Beret medic and a registered herbalist informs this comprehensive guide covering first-aid essentials and the basics of using herbal medicine effectively. In addition to outlining the most useful herbs and specific herbal care protocols for a multitude of acute health issues, readers learn to assess a patient; determine potency and calculate dosage of herbal preparations; and deliver the right herbs to the right tissues.

Paper; 416 pages; 6 x 9
Two-color
\$24.95 US
ISBN 978-1-63586-193-8

Hardcover; 416 pages; 6 x 9
Two-color
\$35.00 US
ISBN 978-1-63586-194-5

Herbs for Children's Health

In this highly accessible handbook, best-selling author and herbal medicine expert Rosemary Gladstar offers her time-tested, safe and gentle natural recipes, along with simple care advice, for addressing children's everyday health needs. Parents of babies and toddlers will discover how easy it is to create a home medicine cabinet of herbal remedies for addressing everything from colic to cradle cap, diaper rash, earaches, colds, cuts, teething, and more. Gladstar's child-tested recipes feature appealing flavors in forms kids love, including teas, syrups, herbal ice pops, “candy” balls, and herbal baths.

Paper; 208 pages; 7 x 9
Full-color
\$19.99 US
ISBN 978-1-63586-828-9

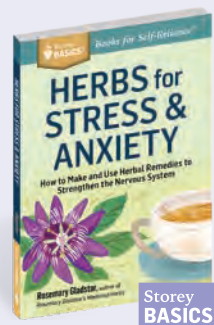

Herbs for Stress & Anxiety

This accessible guide profiles the most effective herbs for addressing common stress symptoms, from panic attacks and depression to migraines and insomnia, and includes simple techniques for making herbal remedies to soothe nervous system issues.

Paper; 128 pages; 5 x 7
Illustrations throughout
\$8.99 US
ISBN 978-1-61212-429-2



Herbs for Natural Beauty

From face creams to body scrubs, massage oils, and shampoos, these recipes use herbs, essential oils, and other common ingredients as the foundation for gentle, effective, all-natural body care treatments that are easy to make.

Paper; 128 pages; 5 x 7
Illustrations throughout
\$9.99 US
ISBN 978-1-61212-473-5



Herbs for Long-Lasting Health

With a focus on 22 herbs that enhance vitality and well-being, this useful primer includes 15 recipes for making effective tinctures, teas, tonics, and more, including Longevity Tonic, 7-Herb Long-Life Soup, and Brain Tonic Tincture.

Paper; 128 pages; 5 x 7
Illustrations throughout
\$9.99 US
ISBN 978-1-61212-471-1

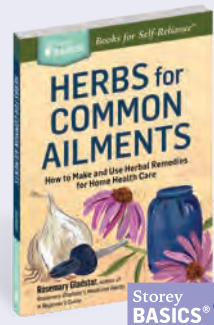

Herbs for Common Ailments

Here is the perfect basic guide to the effective herbal remedies that everyone should have in their medicine chest, along with recipes for easing common ailments such as colds, bruises, and muscle aches and pains.

Paper; 128 pages; 5 x 7
Illustrations throughout
\$9.99 US
ISBN 978-1-61212-431-5

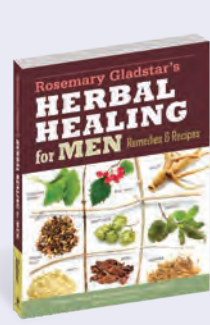

Rosemary Gladstar's Herbal Healing for Men

Treating men's wellness issues—such as sexual vitality, prostate health, and heart strength—is easy with this inviting introduction, which features dozens of delicious and simple herbal formulas. In-depth profiles of 30 herbs explain how men will benefit from each and provide a variety of suggested uses and accessible preparation tips.

■ Silver Nautilus Award

Paper; 224 pages; 7 x 9
Full-color
\$19.99 US
ISBN 978-1-61212-477-3



Healing Herbal Teas

SARAH FARR

Master herbalist Sarah Farr shares 101 original recipes for delicious herbal teas that benefit whole-body and seasonal health needs, along with guidance on the art of tea blending for readers seeking to develop their own signature mixtures.

Paper; 272 pages; 7 1/2 x 7 1/2
Full-color
\$17.99 US
ISBN 978-1-61212-574-9



Grow Your Own Herbal Remedies

MARIA NOËL GROVES

With 23 herb garden plans accompanied by simple recipes for herbal preparations, readers will cultivate the medicine their bodies need, whether they're seeking headache relief, immune support, stress relief, or treatment for chronic stomach problems.

Paper; 336 pages; 8 x 10
Full-color
\$24.95 US
ISBN 978-1-63586-013-9



Body into Balance

MARIA NOËL GROVES

This comprehensive home health guide examines how each body system—including respiratory, digestive, immune, nervous, and reproductive—optimally functions and how to naturally restore lost vitality using herbal medicine as part of a holistic preventive self-care program.

■ Silver Nautilus Award

■ 52,000 COPIES IN PRINT

Paper; 336 pages; 8 x 10
Full-color
\$25.99 US
ISBN 978-1-61212-535-0
Hardcover; \$34.99 US
ISBN 978-1-61212-807-8



The Moon Cycle Cookbook

DEVON LOFTUS & JENNA RADOMSKI

Moon Cycle bakery founder Devon Loftus and nutritionist Jenna Radomski empower women to nourish themselves with recipes for sweets, savory meals, and snacks, organized around each phase of the menstrual cycle. Every recipe is formulated with the knowledge of what is happening hormonally in a woman's body during each cycle phase, using ingredients that replenish and support essential nutrients.

Paper; 240 pages; 6 1/2 x 8 1/2
Full-color
\$19.99 US
ISBN 978-1-63586-285-0



Christopher Hobbs's Medicinal Mushrooms: The Essential Guide

CHRISTOPHER HOBBS

Christopher Hobbs, profiles the most powerful medicinal mushrooms and explains the nutritional and medicinal compounds in each one. Detailed instructions cover how to select, store, and prepare each variety for use, whether readers are sourcing mushrooms from a local provider or growing or foraging their own.

Paper; 272 pages; 7 x 9
Full-color
\$24.95 US
ISBN 978-1-63586-167-9

BEST-SELLING AUTHOR STEPHANIE L. TOURLES



Pure Skin Care

Consumers seeking nontoxic, all-natural skin care products can now make their own at home. Stephanie L. Tourles shares her 78 all-time favorite recipes for cleansers, moisturizers, and exfoliants for face and body that can be customized for skin type, plus formulas for treating common skin conditions.

Hardcover with concealed wire-o; 256 pages; 7 x 9
Full-color
\$19.95 US
ISBN 978-1-63586-050-4



Naturally Bug-Free

Nontoxic alternatives to chemical-laden repellents are easy to make, and these 75 all-natural recipes are safe and effective. This collection includes sprays, balms, body oils, and tinctures for protection from mosquitoes, ticks, and other biting insects, as well as herbal pet shampoos, flea collars, and powders.

Paper; 176 pages; 5 x 7
Two-color
\$10.99 US
ISBN 978-1-61212-596-1



Stephanie Tourles's Essential Oils: A Beginner's Guide

This friendly, accessible introduction highlights the key characteristics of the 25 most versatile and popular essential oils, including lavender, chamomile, eucalyptus, lemon, peppermint, rosemary, and tea tree. Readers will learn how to blend and apply these highly concentrated aromatherapy oils safely and effectively in 100 recipes that enhance well-being and promote healing.

Paper; 248 pages; 7 x 9
Full-color
\$16.95 US
ISBN 978-1-61212-874-0

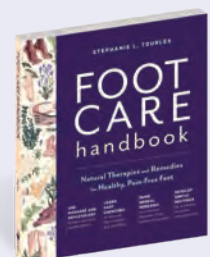

Foot Care Handbook

Best-selling author, herbalist, and certified foot reflexologist Stephanie Tourles sets out to help readers experience the feelgood benefits of healthy feet. Along with natural remedies for common foot problems she explores foot physiology; exercises for stretching and strengthening feet; massage techniques for foot relaxation and restoration; reflexology; and the essential foot care supplies to always have on hand.

Paper; 144 pages; 6 1/2 x 7
Full-color
\$16.95 US
ISBN 978-1-63586-339-0

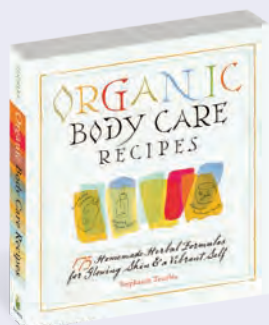

Organic Body Care Recipes

Recipes for luscious lotions, scrubs, toners, masks, and more make it easy for home crafters of every skin type to personalize their beauty regimen while maintaining radiantly healthy skin, hair, feet, hands, and nails.

■ **143,000 COPIES IN PRINT**
Paper; 384 pages; 8 x 8 1/2
Two-color
\$18.95 US
ISBN 978-1-58017-676-7

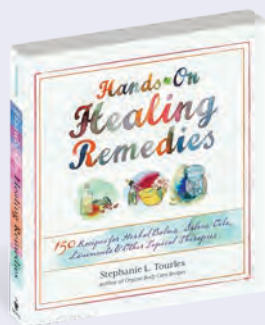

Hands-On Healing Remedies

Treat a wide range of conditions—from headaches and arthritis to tendinitis, fungal infections, anxiety, and cracked skin—with these 150 all-natural recipes for herbal balms, oils, salves, liniments, and other topical ointments.

Paper; 320 pages; 8 x 8 1/2
Two-color
\$18.95 US
ISBN 978-1-61212-006-5



Making Love Potions

These 64 easy recipes for herbal body oils, balms, tonics, bath blends, and sweet treats to share with that special someone will arouse all the senses.

Paper with flaps; 192 pages; 7 x 7
Full-color
\$16.95 US
ISBN 978-1-61212-572-5

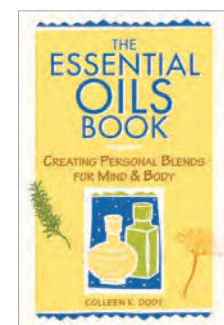

The Essential Oils Book

COLLEEN K. DODY

Whether soothing or invigorating, aromatic essential oils can be used in air fresheners, home-cleaning products, bath soaks, and, of course, perfumes. This practical guide shows readers how to use essential oils safely and effectively, with profiles of 33 common essential oils, plus dozens of recipes and tips.

■ **94,000 COPIES IN PRINT**

Paper; 160 pages; 6 x 9
Two-color
\$14.95 US
ISBN 978-0-88266-913-7

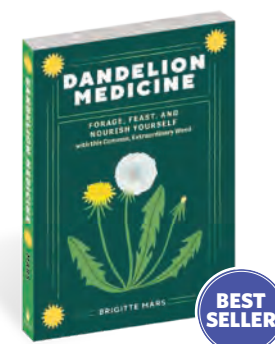

Dandelion Medicine

BRIGITTE MARS

Discover the many healing and culinary uses of the dandelion, with this colorful, accessible guide from a leading medical herbalist. From dandelion root “coffee” to dandelion flower cookies, there are dozens of delicious ways to use the plant in food, and all parts of the dandelion are medicinal in a variety of ways. Herbalist Brigitte Mars provides ways to use the plant, she also shares some of the history and lore surrounding the dandelion, creating a book that is both a practical guide and a fascinating read.

Paper; 192 pages; 5 x 7
Two-color with 16-page full-color insert
\$16.99 US
ISBN 978-1-63586-763-3



Perfumes, Splashes & Colognes

NANCY M. BOOTH

A quick scent profile quiz helps readers pinpoint their fragrance preferences before creating customized perfumes, splashes, and colognes using herbs, essential oils, fragrance oils, and alcohol. Readers will also learn to recreate their favorite commercial perfumes at a fraction of the price; properly care for and store their homemade fragrances; and attractively package their creations.

■ **37,000 COPIES IN PRINT**

Paper; 176 pages; 6 x 9
Two-color
\$14.95 US
ISBN 978-0-88266-985-4



Making Aromatherapy Creams & Lotions

DONNA MARIA

Here is the guide to creating personalized facial creams, body rubs, lip balms, and more using a simple five-step method, all-natural ingredients, and the power of aromatherapy. It includes an overview of aromatherapy, techniques for extracting aromatic plant materials, and 101 recipes.

■ **58,000 COPIES IN PRINT**

Paper; 168 pages; 6 x 8 1/2
Two-color
\$16.95 US
ISBN 978-1-58017-241-7

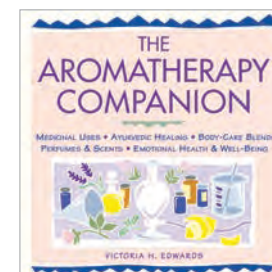

The Aromatherapy Companion

VICTORIA H. EDWARDS

Hundreds of soothing and healing recipes for beauty, good health, and physical and emotional well-being teach readers to use essential and carrier oils in creating bath, massage, and aphrodisiac blends. While some special recipes are inspired by mythology, astrology, and Ayurvedic medicine, this comprehensive volume also guides readers in creating custom mixtures.

■ **45,000 COPIES IN PRINT**

Paper; 288 pages; 8 x 8
Two-color
\$19.95 US
ISBN 978-1-58017-150-2

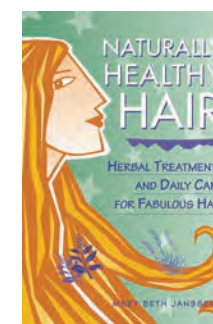

Naturally Healthy Hair

MARY BETH JANSSEN

Every day can be a good hair day with these tips for maintaining radiant tresses and recipes for customized plant-based shampoos and conditioners. In addition, readers will learn about foods, vitamins, and minerals for healthy locks; Ayurvedic practices that can invigorate hair; and healthful approaches to cutting, coloring, and styling.

Paper; 192 pages; 6 x 9
Illustrations throughout
\$16.95 US
ISBN 978-1-58017-129-8



Natural Hair Coloring

CHRISTINE SHAHIN

Rich, natural-looking hair color is attainable and affordable with all-natural plant pigments. Henna, indigo, amla, and cassia make it possible to achieve stunning shades of brown, black, red, and even blond that effectively cover gray hair.

Paper; 184 pages; 7 x 9
Full-color
\$18.95 US
ISBN 978-1-61212-598-5

“Everything one needs to know to utilize this nutritious herb is enthusiastically and knowledgeably shared - from wildcrafting to cultivation, kitchen to apothecary, food to beauty, and more. A book for every herb enthusiast!”

— Mindy Green, herbalist, aromatherapist, esthetician



Nettle Power

BRIGITTE MARS

A colorful, highly accessible guide to the healing and culinary uses of nettle, a protein-packed wild plant that is a favorite of foragers and herbalists. A plentiful wild plant with a long history of use, nettle helps soothe skin conditions, strengthen bones, restore the nervous system, and boost the immune system, among its many benefits. Author Brigitte Mars shares a range of recipes for using the nutrient-dense green leaves as a tasty substitute for spinach or chard in salads, soups, and main dishes, along with healing recipes for teas, tinctures, juices, and elixirs.

Paper; 152 pages; 5 x 7
Full-color
\$18.99 US
ISBN 978-1-63586-841-8

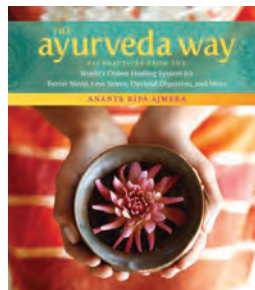

The Ayurveda Way

ANANTA RIPA AJMERA

The ancient Indian medical tradition of Ayurveda—yoga’s sister science—comes alive for contemporary holistic health enthusiasts in this inspiring introductory guide. The 108 self-care exercises and short essays make Ayurvedic approaches to promoting optimal digestion, better sleep, less stress, and a more balanced life attainable even for beginners.

- Gold Foreword INDIES Award
- Silver Nautilus Award

Hardcover; 256 pages; 6½ x 7½
Full-color
\$18.95 US
ISBN 978-1-61212-818-4



Being with Trees

HANNAH FRIES

Poet and nature lover Hannah Fries invites readers to slow down and connect with the wonders and healing power of nature, featuring a guided journey of prompts, poetry, meditations, and inspirational photos, with a foreword by Robin Wall Kimmerer, author of *Braiding Sweetgrass*.

Paper; 192 pages; 6 x 6
Full-color
\$14.95 US
ISBN 978-1-63586-605-6

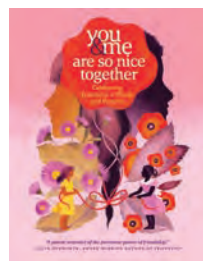

You & Me are So Nice Together

MARLENA AGENCY

Sixty international, prize-winning artists put a fresh visual spin on the many facets and values of friendship. Each artist has chosen and illustrated a quotation they find particularly inspiring and personally meaningful. Two pull-out postcards featuring art from the book are included as a bonus feature.

Hardcover; 144 pages; 5 x 7
Full-color
\$12.95 US
ISBN 978-1-63586-432-8



Girls' Home Spa Lab

MAYA PAGÁN

Packed with all-natural body care formulas, healthy recipes, easy yoga poses, and natural remedies, this fun guide gives active, plugged-in tween girls healthy ways to de-stress and build essential self-care routines into daily life.

- For ages 9–13
- Gold Mom’s Choice Award

Paper; 160 pages; 8 x 10
Full-color
\$16.95 US
ISBN 978-1-61212-964-8



Joy in Every Moment

TZIVIA GOVER

For those looking to increase their daily joy quotient, this illustrated volume of short essays and practical exercises offers creative ways to uncover gladness every day, anywhere.

Paper with flaps; 220 pages; 6 x 7
Two-color with 10 full-color illustrated inserts
\$12.95 US
ISBN 978-1-61212-511-4

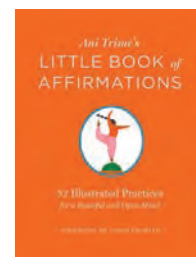

Ani Trime's Little Book of Affirmations

ANI TRIME

“Every thought I think is creating my future.” So begin the 52 affirmations of Ani Trime, a beloved teacher in the Tibetan Buddhist tradition known for her humor and no-nonsense approach to spiritual practice. This illustrated pocket-size volume of her affirmative statements teaches people to cultivate a freer, healthier, more open mind.

Hardcover; 136 pages; 3½ x 4½
Full-color
\$12.95 US
ISBN 978-1-63586-184-6



Everyday Gratitude Frame-Ups

Display, swap, and cherish 50 inspiring sayings, including selections from the best-selling *Everyday Gratitude*. Each pull-out card features a hand-lettered quote on a colorful background and fits the stand-up detachable frame included on the inside cover. Set it up anywhere a little reminder to appreciate every moment is welcome.

Paper with stand-up cardstock easel; 100 pages; 7½ x 7
Full-color
\$14.95 US
ISBN 978-1-63586-242-3



Everyday Gratitude

This beautiful, curated collection of quotes and reflections calls attention to the abundance of things to be grateful for in daily life. Inspiration from well-known minds such as Maya Angelou, Confucius, and Anne Frank combined with simple prompts for gratitude practices will help readers recognize everyday opportunities for gratefulness and joy.

Paper with flaps and ribbon bookmark; 304 pages; 6 x 6
Full-color
\$14.95 US
ISBN 978-1-63586-046-7



The Gratitude Explorer Workbook

KRISTI NELSON

This interactive package is a guide and a journal for recording thoughts and meditations. Dozens of writing prompts, guided meditations, and exercises for beginning and progressively deepening a daily gratitude practice are paired with quotations and space for writing. Includes quotation postcards, mini-cards, conversation starters, gold star stickers, and reusable affirmation stickers, as well as bookmarks.

Paper; 128 pages; 6 x 8
full-color
\$16.95 US
ISBN 978-1-63586-206-5

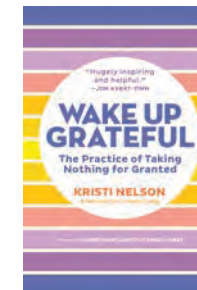

Wake Up Grateful

KRISTI NELSON

In *Wake Up Grateful*, Kristi Nelson, executive director of A Network for Grateful Living, unlocks the path to recognizing abundance in every moment, no matter the moment. With questions for reflection, daily exercises, and perspective prompts, Nelson introduces readers to the benefits of a daily gratitude practice.

Paper; 240 pages; 5½ x 8½
\$18.99 US
ISBN 978-1-63586-664-3



Herbal Goddess

AMY JIRSA

Accessing nature’s restorative powers begins by fully embracing the distinctive qualities of 12 versatile herbs. Each chapter explores one herb in depth, with recipes for food, drink, and body care, as well as suggestions for incorporating that herb’s properties into meditation and yoga.

Paper; 256 pages; 6½ x 8½
Full-color
\$19.95 US
ISBN 978-1-61212-412-4

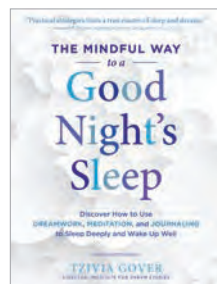

The Mindful Way to a Good Night's Sleep

TZIVIA GOVER

This encouraging self-help guide combines mindfulness and dreamwork to present accessible, effective techniques for achieving peaceful, restful sleep—naturally—using simple yoga poses, 10-minute meditations, easy breathing exercises, and tips for cultivating dream recall.

Paper; 184 pages; 6 x 8
Two-color
\$16.95 US
ISBN 978-1-61212-882-5



Make Your Own Pure Mineral Makeup

HEATHER ANDERSON

With 79 formulas for eye shadow, foundation, concealer, blush, bronzer, and more, readers will learn the easy and inexpensive process of making their own naturally derived cosmetics. These mineral-based powders protect and promote healthy skin and the recipes detail how to customize for skin type and color.

Paper; 256 pages; 7 x 9
Full-color
\$19.95 US
ISBN 978-1-61212-752-1

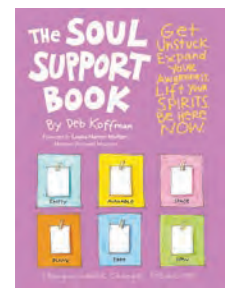

The Soul Support Book

DEB KOFFMAN

Wise, witty, and unconventional, every page in this collection of cartoons is a mini-meditation that puts a fresh spin on universal truths derived from ancient wisdom. The soul-soothing observations are encouraging, eye-opening, and so darn true that readers will want to carry this pocket-size volume with them everywhere.

Paper with flaps; 112 pages; 5¼ x 7
Full-color
\$12.99 US
ISBN 978-1-63586-601-8



Birthing Mama

CORINNE ANDREWS

Expectant mothers will find a holistic, encouraging guide and a place to record their thoughts and experiences. Whether setting up a Pregnancy Alter to focus their hopes and dreams for the baby-to-be, writing a Family Mission Statement, blending an herbal tea formula for morning sickness, they can cultivate their own blend of self-care and self-discovery, and contemplation and celebration.

Paper; 256 pages; 7 x 9
Full-color
\$19.95 US
ISBN 978-1-63586-312-3



Micro Activism

OMKARI L. WILLIAMS

In *Micro Activism*, former political consultant turned activism coach Omkari Williams shares her expertise in empowering introverts and highly sensitive people to help each of us, no matter our temperament, find our most satisfying and effective activist role. Using Williams’s Activist Archetype tool, readers discover their unique strengths and use this to develop a personal strategy.

- NAUTILUS BOOK AWARDS, GOLD WINNER

Paper; 176 pages; 5½ x 8½
Illustrations throughout
\$17.99 US
ISBN 978-1-63586-688-9



Leaning Toward Light

EDITED BY TESS TAYLOR

In this poetry anthology, acclaimed poet Tess Taylor brings together a diverse range of contemporary voices to offer poems that celebrate that joyful connection to the natural world. A foreword by Aimee Nezhukumatathil, along with original illustrations by Melissa Castrillon, and a ribbon bookmark complete this stunning gift format.

Hardcover; 200 pages; 6¼ x 8¼
Full-color
\$22.00 US
ISBN 978-1-63586-580-6



The Wonder of Small Things

EDITED BY JAMES CREWS

This collection of highly accessible poems focuses on the theme of celebrating moments of wonder and peace in everyday life. The anthology features a carefully curated selection of poems from a diverse range of authors. Readers are guided through a series of reflective pauses and reading group questions in the back.

Paper; 224 pages; 5 x 7
Illustrations throughout
\$14.99 US
ISBN 978-1-63586-644-5



The Path to Kindness

EDITED BY JAMES CREWS

James Crews presents an anthology of poems that explore the theme of kindness, featuring more than 100 uplifting and accessible poems by a diverse group of well-known and emerging contemporary poets, including Julia Alvarez, Marie Howe, Ellen Bass, Naomi Shihab Nye, Ross Gay, Ada Limón, Danusha Lameris, Alberto Ríos, and more.

Paper; 224 pages; 5 x 7
Illustrations throughout
\$14.95 US
ISBN 978-1-63586-533-2



How to Love the World

EDITED BY JAMES CREWS

How to Love the World invites readers to use poems as part of their daily gratitude practice. Works by contemporary poets such as Amanda Gorman, Joy Harjo, Ellen Bass, Naomi Shihab Nye, Ross Gay, and Tracy K. Smith, reveal the simple gifts that can be found everywhere. Invitations for writing and reflection, and topics for discussion are included.

Paper with flaps; 208 pages; 5 x 7
\$14.99 US
ISBN 978-1-63586-386-4

BEST-SELLING AUTHOR MAIA TOLL

BEST
SELLER

The Illustrated Herbiary

The symbolism of plants has fascinated people for centuries. In this beautifully illustrated book, profiles bring the unique and mysterious personalities of 36 herbs, fruits, and flowers to life, along with reflections and rituals for healing and everyday guidance. Thirty-six cards featuring artwork from the book help guide readers' meditations.

■ 137,000 COPIES IN PRINT
■ Gold Nautilus Award

Hardcover with 9 cardstock sheets in a bound-in envelope; 168 pages; 6 x 8
Full-color
\$19.95 US
ISBN 978-1-61212-968-6

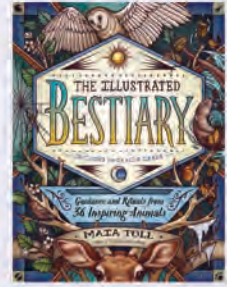

The Illustrated Bestiary

Humans across cultures and through the centuries have felt a spiritual, symbolic connection to animals. Profiles of 36 animals' most meaningful traits explore how those qualities can illuminate people's habits, guide their intentions, and inform their actions. Rituals and reflections assist readers in cultivating each animal's energy, while 36 art-filled oracle cards further focus readers' thoughts.

■ 41,000 COPIES IN PRINT

Hardcover with 9 cardstock sheets in a bound-in envelope; 168 pages; 6 x 8
Full-color
\$19.95 US
ISBN 978-1-63586-212-6

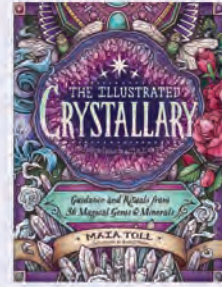

The Illustrated Crystallary

Explore the mystical aspects of 36 gems and minerals, including turquoise, topaz, opal, quartz, and more. Ritual practices and questions for reflection and journaling, coupled with pull-out oracle cards, invite readers to ponder the life lessons each crystal offers. Evocative illustrations by Kate O'Hara illuminate the qualities and symbolism of each stone.

Hardcover with 9 cardstock sheets in a bound-in envelope; 168 pages; 6 x 8
Full-color
\$20.00 US
ISBN 978-1-63586-222-5



Maia Toll's Wild Wisdom Companion

In this capstone to the Wild Wisdom series, Maia Toll guides readers in developing a personalized earth-based spiritual practice using rituals, writing prompts, and reflections tied to each season. Combining practical exercises with rituals, ancient teachings, magical symbols, and herbal recipes, this unique almanac promises to be a powerful tool for personal transformation, year after year.

Hardcover with 4 pocket gatefold inserts and 7 cardstock sheets in a bound-in envelope; 192 pages; 8 x 8
Full-color
\$24.95 US
ISBN 978-1-63586-129-7



NEW

Maia Toll's Wild Wisdom Tattoos

This collection includes 60 richly colored temporary tattoos featuring mystical images of plants, animals, and crystals, adapted from Maia Toll's best-selling Wild Wisdom books and illustrated by Kate O'Hara, along with 10 guided-ritual cards for tapping into the symbolic power and magic of key images.

Paper; 40 pages; 5¼ x 7
Full-color
\$16.99 US
ISBN 978-1-63586-861-6



NEW

Maia Toll's Wild Wisdom Collection

Tap into the wild wisdom of plants, animals, and crystals in this stunning boxed set that includes the three books in the Wild Wisdom series—*The Illustrated Herbiary*, *The Illustrated Bestiary*, and *The Illustrated Crystallary*—along with 108 oracle cards and a divination mat.

Hardcover; 504 pages; 6¼ x 8½ x 3¼
Full-color; includes 108 oracle cards and divination mat
\$60.00 US
ISBN 978-1-63586-864-7



The Illustrated Herbiary Collectible Box Set

Featuring *The Illustrated Herbiary* book along with a freestanding deck of 36 large, gilt-edged oracle cards and a cloth carrying pouch.

Hardcover with deluxe card set and carrying pouch; 168 pages; 6 x 8
Full-color
\$29.95 US
ISBN 978-1-63586-246-1

Also Available: The Illustrated Bestiary Collectible Box Set

Hardcover with deluxe card set and carrying pouch; 168 pages; 6 x 8
Full-color
\$29.95 US
ISBN 978-1-63586-336-9



The Illustrated Herbiary Oracle Cards

36-card deck plus 40-page booklet in a gift box;
4.125 x 5.25 x 1.25; Full-color
\$19.99 US
ISBN 978-1-63586-485-4



The Illustrated Bestiary Oracle Cards

36-card deck plus 40-page booklet in a gift box;
4.125 x 5.25 x 1.25; Full-color
\$19.99 US
ISBN 978-1-63586-486-1



The Illustrated Crystallary Oracle Cards

36-card deck plus 40-page booklet in a gift box;
4.125 x 5.25 x 1.25; Full-color
\$19.99 US
ISBN 978-1-63586-487-8



The Illustrated Herbiary Puzzle: California Poppy

750-piece jigsaw puzzle;
7.677 x 10.748 x 2.125
Full-color
\$19.95 US
ISBN 978-1-63586-403-8



The Illustrated Bestiary Puzzle: Monarch Butterfly

750-piece jigsaw puzzle;
7.677 x 10.748 x 2.125
Full-color
\$19.95 US
ISBN 978-1-63586-404-5



The Illustrated Crystallary Puzzle: Garden Quartz

750-piece jigsaw puzzle;
7.677 x 10.748 x 2.125
Full-color
\$19.95 US
ISBN 978-1-63586-405-2



The Love Lives of Birds

LAURA ERICKSON

Ornithologist Laura Erickson takes readers on a romance-fueled romp through the love lives of 35 species, exploring the diversity of avian approaches to pairing up. Each species spotlight pairs Erickson's remarkable depth of scientific knowledge with her talent for drawing humorous and insightful parallels between human and bird.

Hardcover; 152 pages; 7 x 8
Full-color
\$19.95 US
ISBN 978-1-63586-275-1



Backyard Foraging

ELLEN ZACHOS

Many edible plants can be found in backyards, lawns, and parks. Vacant lots host edibles such as sumac, purslane, and Japanese knotweed. Urban parks may offer up garlic mustard and ginkgo nuts. And lawns can be full of sheep sorrel, chickweed, dandelion, and pineapple weed. Invaluable safety tips and harvesting etiquette accompany these profiles of 65 edible weeds and ornamental plants, as well as a few mushrooms.

■ 67,000 COPIES IN PRINT

Paper; 240 pages; 7 x 9
Full-color
\$16.99 US
ISBN 978-1-61212-009-6

ALSO AVAILABLE:
The Wildcrafted Cocktail, page 61



How to Forage for Wild Foods Without Dying Journal

ELLEN ZACHOS

This seasonal journal for tracking the locations and dates of foraged foods includes essential foraging guidelines and an extensive table of edible plants and mushrooms for each season. Throughout the book, author and expert forager Ellen Zachos offers essential advice for safe foraging and extensive lists of wild edibles and mushrooms for each season.

Paper with elastic closure; 192 pages;
5½ x 7
Full-color
\$16.99 US
ISBN 978-1-63586-786-2



How to Forage for Mushrooms Without Dying

ELLEN ZACHOS

Hyman offers his expert mushroom foraging advice on how to identify 29 edible mushrooms, distilling down the most important information for the reader in language that's easy to remember when in the field. With easy-to-follow guidelines, this on-the-go package features rounded corners for durability and an easy-to-clean cover.

Paper; 256 pages; 5½ x 7
Full-color
\$16.99 US
ISBN 978-1-63586-332-1

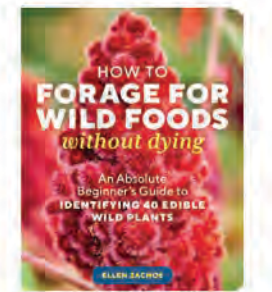

How to Forage for Wild Foods Without Dying

ELLEN ZACHOS

Zachos has curated the 40 most common, most delicious edible plants, ranging from black walnuts and juniper berries to elderflowers, wild garlic and many more. With Zachos's expert advice and easy-to-follow guidelines, readers will be confident in identifying which plants they can safely eat and which ones they should definitely avoid.

Paper; 256 pages; 5½ x 7
Full-color
\$16.99 US
ISBN 978-1-63586-613-1

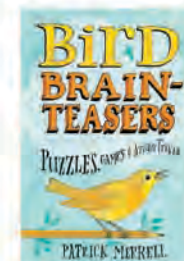

Bird Brainteasers

PATRICK MERRELL

Bird-watchers and puzzle fans alike will delight in this fresh collection of games and puzzles. Packed with bird-themed crosswords, visual puzzles, and the first-ever Birdoku challenges, this book also features avian facts, trivia, and lore.

Paper; 324 pages; 4 x 6
Two-color
\$9.99 US
ISBN 978-1-60342-080-8

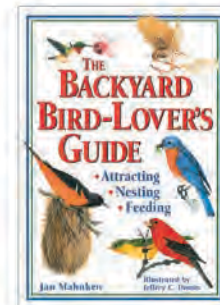

The Backyard Bird-Lover's Guide

JAN MAHNKEN

This colorful, information-packed reference on attracting, feeding, and watching a wide variety of birds introduces 135 North American species. Beautiful, detailed paintings accompany comprehensive profiles that highlight each bird's territory and its courtship, nesting, and parenting characteristics.

■ 119,000 COPIES IN PRINT

Paper; 320 pages; 7 x 10
Full-color
\$24.99 US
ISBN 978-0-88266-927-4



The Bird Watching Answer Book

LAURA ERICKSON

In this handy, pocket-size volume, the Cornell Lab of Ornithology answers hundreds of birders' in-the-field questions—including "How do birds prepare for long migrations?" "How well do birds hear?" and "Do birds play?"

Flexibind with paper spine; 400 pages;
4¼ x 6¾
Two-color
\$15.99 US
ISBN 978-1-60342-452-3

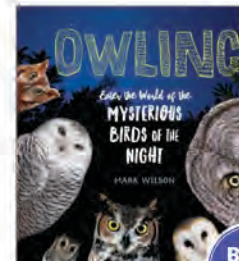

Owling

MARK WILSON

Young readers are invited into the world of owls for an up-close look at their lives, behavior, and abilities. Kids will learn about the birds' silent flight, remarkable eyes and ears, and haunting calls through dramatic photographs of 19 North American species nesting, flying, hunting, and catching prey.

■ For ages 8-12
■ AAAS/Subaru Award

Hardcover with glow-in-the-dark ink on cover; 120 pages; 11 x 11
Full-color
\$19.99 US
ISBN 978-1-61212-962-4



Into the Nest

LAURA ERICKSON & MARIE READ

This beautifully photographed book portrays the lesser known courting and family lives of familiar birds, showing the entire life cycle in intimate detail. For each species group there are photographs of the male and female, courtship, nest construction, eggs, parents on the nest, nestlings, feeding time, and the flight of fledglings.

Paper; 208 pages; 9¼ x 8½
Full-color
\$17.95 US
ISBN 978-1-61212-229-8

BEST-SELLING AUTHOR JULIA ROTHMAN

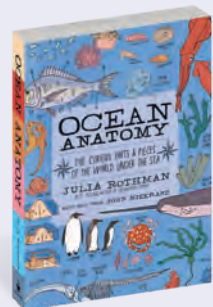

Ocean Anatomy
 ■ 128,000 COPIES IN PRINT
 Paper with flaps; 208 pages; 6½ x 9
 Full-color
\$18.99 US
 ISBN 978-1-63586-160-0

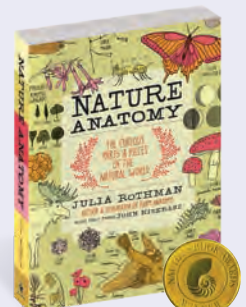

Nature Anatomy
 ■ Gold Nautilus Award
 ■ Sigurd F. Olson Young Adult Notable Book
 ■ 230,000 COPIES IN PRINT
 Paper with flaps; 224 pages; 6½ x 9
 Full-color
\$18.99 US
 ISBN 978-1-61212-231-1



Farm Anatomy
 ■ 136,000 COPIES IN PRINT
 Paper with flaps; 224 pages; 6½ x 9
 Full-color
\$18.99 US
 ISBN 978-1-60342-981-8

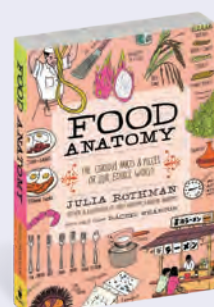

Food Anatomy
 ■ 70,000 COPIES IN PRINT
 Paper with flaps; 224 pages; 6½ x 9
 Full-color
\$18.99 US
 ISBN 978-1-61212-339-4

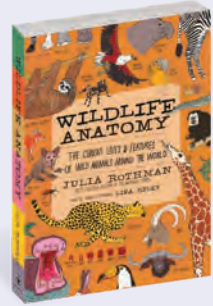

Wildlife Anatomy
 Paper with flaps; 208 pages; 6½ x 9
 Full-color
\$18.99 US
 ISBN 978-1-63586-388-8



Nature Anatomy Sticker Book
 Pad binding; 56 pages; 6 x 9
 Full-color
\$12.95 US
 ISBN 978-1-63586-536-3



Ocean Anatomy Sticker Book
 Pad binding; 56 pages; 6 x 9
 Full-color
\$12.95 US
 ISBN 978-1-63586-537-0



Farm Anatomy Sticker Book
 Pad binding; 56 pages; 6 x 9
 Full-color
\$12.95 US
 ISBN 978-1-63586-538-7



Nature Anatomy: The Puzzle
 500-piece jigsaw puzzle;
 10.2362 x 8.188 x 2
 Full-color
\$19.95 US
 ISBN 978-1-63586-401-4



Ocean Anatomy: The Puzzle
 500-piece jigsaw puzzle;
 10.2362 x 8.188 x 2
 Full-color
\$19.95 US
 ISBN 978-1-63586-402-1



Nature Anatomy Notebook
 Paper with exposed stitched spine and removable belly band;
 176 pages; 6½ x 9
 Full-color
\$24.99 US
 ISBN 978-1-63586-442-7



The Julia Rothman Collection
 ■ 88,000 COPIES IN PRINT
 Paper; 672 pages; 6½ x 9¼
 Full-color
\$57.00 US
 ISBN 978-1-61212-852-8

ALSO AVAILABLE JULIA ROTHMAN CHILDREN'S BOOKS SEE PAGE 69

BEST-SELLING AUTHOR CLARE WALKER LESLIE

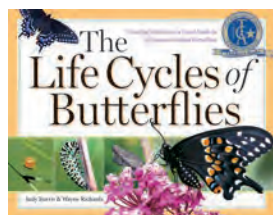

The Life Cycles of Butterflies
 JUDY BURRIS & WAYNE RICHARDS
 More than 400 stunning up-close photographs, all taken in live garden settings, show the life cycles of 23 common backyard butterflies. Each butterfly is shown from start to maturity, with sequential photographs of the egg, caterpillar, chrysalis, and emerging butterfly—a richly visual guide to one of nature's most wondrous creations.
 ■ Teachers' Choice Children's Book Award
 ■ 62,000 COPIES IN PRINT
 Paper; 160 pages; 9¼ x 7½
 Full-color
\$16.99 US
 ISBN 978-1-58017-617-0

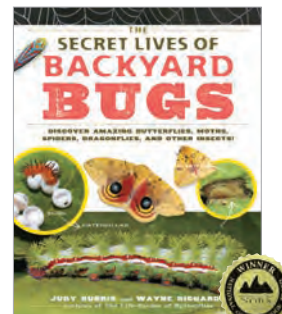

The Secret Lives of Backyard Bugs
 JUDY BURRIS & WAYNE RICHARDS
 This is an up-close-and-personal tour of the hidden lives of spiders, beetles, butterflies, moths, crickets, dragonflies, damselflies, grasshoppers, aphids, and other backyard residents. Each creature is shown in its natural setting, and many are shown progressing through the stages of their life cycles.
 ■ National Outdoor Book Award
 Paper; 136 pages; 8 x 10
 Full-color
\$16.99 US
 ISBN 978-1-60342-563-6



How to Look at a Bird
 Clare Walker Leslie
 Bestselling author Clare Walker Leslie invites beginning bird-watchers to hone their observational skills with this easy-to-use visual guide. With an emphasis on common birds most likely to be seen at a feeder, in a city park, or at a nature preserve, this book makes bird watching, identification, and appreciation accessible to everyone, no matter where they live.
 Paper; 144 pages; 5¼ x 7
 Full-color
\$18.99 US
 ISBN 978-1-63586-649-0

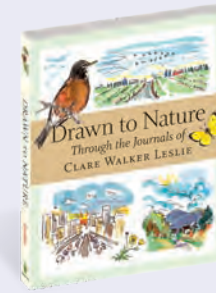

Drawn to Nature
 Through the Journals of Clare Walker Leslie
 Endearing sketches and thought-provoking observations serve as an invitation to readers to slow down and wake up to what's happening in the natural world all around. Signs of nature are everywhere, and this inspirational guide helps readers see with renewed appreciation and joy.
 Paper with flaps; 176 pages; 6½ x 8
 Full-color
\$15.00 US
 ISBN 978-1-58017-614-9

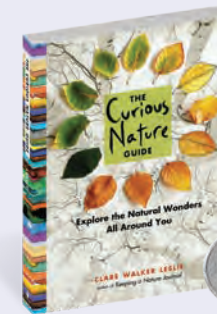

The Curious Nature Guide
 With the help of simple prompts, intriguing facts, charming sketches, and stunning photos, every page of this unique treasure map invites the reader to focus on a particular aspect of the natural world.
 ■ Silver Nautilus Award
 Paper with flaps; 144 pages; 6½ x 8½
 Full-color
\$14.99 US
 ISBN 978-1-61212-509-1



Keeping a Nature Journal, 3rd Edition
 Readers of all ages will reconnect with nature through sketching and writing with these simple methods for capturing the living beauty of each season. This edition features more step-by-step drawing techniques, an expanded range of observation prompts, and a new selection of pages from Leslie's 40-year trove of journals.
 Paper; 224 pages; 8 x 10
 Full-color
\$24.99 US
 ISBN 978-1-63586-228-7



Cattail Moonshine & Milkweed Medicine
 TAMMI HARTUNG
 For millennia, humans have turned to plants for nourishment, shelter, healing, clothing, and entertainment. These illustrated profiles of 43 native North American flowers, herbs, and trees explore the deeply rooted relationship between people and plants, with little-known stories and fascinating facts that will captivate readers.
 ■ Thomas DeBaggio Book Award
 ■ Silver Nautilus Award
 Hardcover; 256 pages; 7 x 7½
 Full-color
\$19.95 US
 ISBN 978-1-61212-660-9

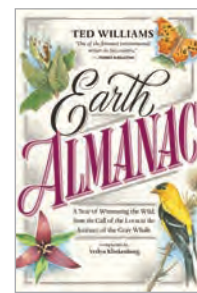

Earth Almanac
 TED WILLIAMS
 In this beautifully crafted collection of 238 seasonal essays, noted nature writer Ted Williams chronicles a full year of nature's wild and fleeting moments, from winter butterflies to summer snow. Williams' evocative writing stands as a testament to nature's fragile beauty and offers ample inspiration for protecting its amazing diversity.
 Paper with flaps and FSC paper; 256 pages; 5¼ x 8
 Full-color
\$16.95 US
 ISBN 978-1-63586-283-6

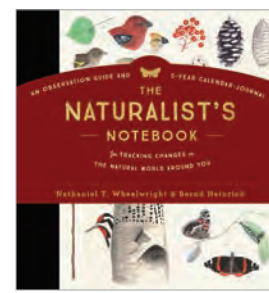

The Naturalist's Notebook
 NATHANIEL T. WHEELWRIGHT & BERND HEINRICH
 The unique five-year format of this nature journal helps readers create a long-term record and point of comparison for memorable events, such as spring's first robin, summer's first monarch butterfly, and winter's first frost. Beautifully rendered illustrations and insightful text teach nature lovers of all ages what to look for, no matter where they live.
 ■ Gold Nautilus Award
 Hardcover with ribbon bookmark; 208 pages; 8 x 8½
 Full-color
\$25.00 US
 ISBN 978-1-61212-889-4



Attracting Native Pollinators
 THE XERCES SOCIETY
 This essential reference provides comprehensive information on every kind of pollinator and shows how to encourage activity from bees, wasps, butterflies, moths, and flies by creating flowering habitats and inviting nesting sites. Anyone can do it! Instructions for building nesting structures and an extensive resource list are included.
 ■ 48,000 COPIES IN PRINT
 Paper; 384 pages; 7 x 10
 Full-color
\$31.99 US
 ISBN 978-1-60342-695-4



Milkweed Lands
 ERIC LEE-MÄDER
 Ecologist Eric Lee-Mäder and noted botanical artist Beverly Duncan have teamed up to create this unique exploration of the complex ecosystem that is supported by the remarkable milkweed plant. With stunning, up-close illustrations and engaging text, they trace every stage of the plant's changes and evolutions throughout the seasons, including germination, growth, flowering, and seed development.
 ■ NATIONAL OUTDOOR BOOK AWARD WINNER
 Hardcover; 120 pages; 7¼ x 10¼
 Full-color
\$20.00 US
 ISBN 978-1-63586-436-6



Being with Trees
 HANNAH FRIES
 Poet and nature lover Hannah Fries invites readers to slow down and connect with the wonders and healing power of nature, featuring a guided journey of prompts, poetry, meditations, and inspirational photos, with a foreword by Robin Wall Kimmerer, author of Braiding Sweetgrass.
 Paper; 192 pages; 6 x 6
 Full-color
\$14.95 US
 ISBN 978-1-63586-605-6

BEST-SELLING SERIES FROM DEANNA F. COOK

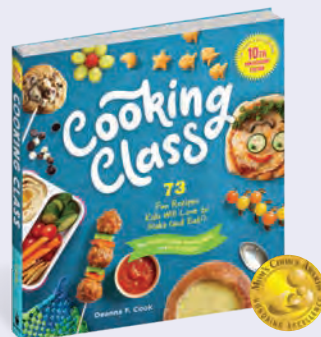

“Of all the kids’ cooking books that have crossed my threshold over the years, this is the one that seems to have struck gold.”

—T. Susan Chang, NPR



Baking Class

This delightful baking guide for kids features 50 easy-to-follow recipes for all their favorites. Lively step-by-step photos teach bakers-in-training how to knead dough and produce a perfect pie, along with essential skills like accurately measuring ingredients.

- For ages 6–12
- National Parenting Product Award
- Gold Mom’s Choice Award
- IACP Award Finalist
- **330,000 COPIES IN PRINT**

Paper with concealed wire-o, 4 sticker sheets, and 5 perforated cardstock sheets; 144 pages; 9 x 9½
Full-color
\$18.95 US
ISBN 978-1-61212-855-9



Cooking Class Global Feast!

Young chefs embark on a tasty tour of global cultures and cuisines with recipes from around the world. A pop-out food passport, language flashcards, and flag stickers provide extra fun.

- For ages 6–12
- National Parenting Product Award
- Gold Mom’s Choice Award
- IACP Award Finalist
- **180,000 COPIES IN PRINT**

Paper with concealed wire-o, 4 sticker sheets, and 5 perforated cardstock sheets; 144 pages; 9 x 9½
Full-color
\$18.95 US
ISBN 978-1-61212-855-9



Cooking & Baking Class Box Set

This slipcase set features the best-selling combo of *Cooking Class* and the IACP Award-winning *Baking Class*, along with a bonus food-grade plastic cutting board.

- For ages 8–12
- **Two paperbacks with concealed wire-o and a food-grade cutting board in a slipcase, shrink-wrapped;** \$40.00 US

ISBN 978-1-63586-079-5



Kids Cook Dinner

DEANNA F. COOK

This selection of 25 easy, budget-friendly dinner recipes from the best-selling *Cooking Class* series teaches kids how to make tasty, healthy meals with easy-to-follow step-by-step photos. With instructions on basic cooking skills, like chopping vegetables and stir-frying, grocery shopping, and kitchen safety, this book offers aspiring chefs ages 8 to 12 everything they need to know.

Paper; 64 pages; 8½ x 9½
Full-color
\$9.95 US
ISBN 978-1-63586-463-2



The Pesto Cookbook

OLWEN WOODIER

Pesto doesn’t have to stop at basil! Cooks, gardeners, and food lovers will unlock the full potential of this classic sauce with recipes that introduce a variety of herbs, vegetables, and nuts into the mix. An additional 67 creative recipes for cooking with pesto show off how versatile this condiment can be.

Paper; 224 pages; 6½ x 8½
Full-color
\$17.99 US
ISBN 978-1-61212-765-1



Curry & Kimchi

UNMI ABKIN & ROGER TAYLOR

Chefs Unmi Abkin and Roger Taylor of the restaurant Coco & The Cellar Bar share the secrets to making and using bold foundational dressings, salsas, broths, and infused oils in Asian-inspired main dishes. Recipes for everything from Honey Miso Noodle Salad and Coco Shoyu Ramen to a Korean take on Bolognese sauce for Korean Sloppy Joes are scaled for the home kitchen and accompanied by vivid photography and elegant plating suggestions.

Hardcover; 176 pages; 8 x 8
Full-color
\$24.95 US
ISBN 978-1-63586-158-7

“This is a book for meat lovers, especially those who want to learn how to make their favorite cut of beef taste best.”

—Nikki Miller-Ka, Food Wine Magazine



Beef It Up!

JESSICA FORMICOLA

In this beef-centric cookbook, popular blogger Jessica Formicola features 50 juicy, budget-friendly recipes that are sure to become family favorites, from soups, salads, and casseroles to the most delicious burgers and perfectly done steaks. Juicy photos provide the inspiration and confidence cooks of all levels need to deliver on the promise of a great meal every time.

Paper; 152 pages; 8 x 9
Full-color
\$16.95 US
ISBN 978-1-63586-453-3

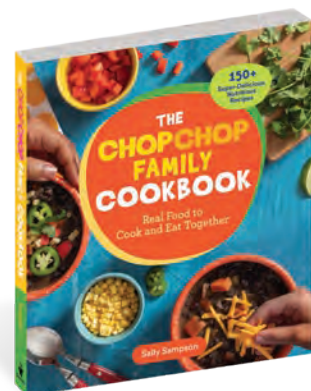

“From the people who know kids’ cooking best, the most wonderful family-friendly cookbook in years.”

—Mark Bittman author of *How to Cook Everything*

The ChopChop Family Cookbook

SALLY SAMPSON

This colorful, easy-to-follow, beginner cookbook from *ChopChop Family* magazine, a James Beard award-winning publication with a mission to get families to cook real food together, features more than 150 recipes for breakfast, lunch, and dinner. Specially designed to appeal to both adults and kids in budget- and time-strapped families, the recipes include favorites like Overnight Oatmeal, Double Vegetable Fried Rice, Free Form Lasagna, and One-Ingredient Banana Ice Cream, along with simple cooking and meal-prep instructions.

Paper; 256 pages; 8 x 9
Full-color
\$19.99 US
ISBN 978-1-63586-525-7



Cast-Iron Cooking

RACHAEL NARINS

Affordable, long-lasting, and incredibly versatile, cast iron is a cooking method unto itself, as well as a great alternative to pans with chemical nonstick coatings. This easy-to-use cookbook features 40 recipes, from classic cornbread to blueberry coffee cake, skillet catfish, pan pizza, and the perfect grilled cheese sandwich.

Paper with flaps; 96 pages; 7 x 9
Full-color
\$12.95 US
ISBN 978-1-61212-676-0



Fish Grilled & Smoked

JOHN MANIKOWSKI

This tasty collection for fishing enthusiasts, home cooks, and campers features 150 recipes for grilled and smoked fresh- and saltwater fish. Foolproof methods for smoking fish on the backyard grill—plus building plans for three smoker models—round out this invaluable resource.

Paper; 264 pages; 7 x 9
Two-color
\$16.95 US
ISBN 978-1-58017-502-9



The Fresh Egg Cookbook

JENNIFER TRAINER THOMPSON

Fresh eggs shine in such classic dishes as Caesar salad, spaghetti carbonara, and deviled eggs—and in innovative recipes for smoothies, appetizers, casseroles, and stews.

Paper; 192 pages; 7 x 9
Full-color
\$14.99 US
ISBN 978-1-60342-978-8



Winner! Winner! Chicken Dinner

STACIE BILLIS

Food editor and cookbook author Stacie Billis’s tips and tricks cover a wide range of techniques, from braising and roasting to grilling, slow cooking, and sheet-pan cooking, helping home cooks serve up tender, flavorful results every time.

Paper; 160 pages; 7½ x 9½
Full-color
\$16.95 US
ISBN 978-1-63586-156-3



Mochi Magic

KAORI BECKER

With these easy-to-follow techniques, home cooks can make hand-pounded, steamed, and microwave mochi, as well as fillings, sauces, savory bites, and adorable mochi animals and flowers. Author Kaori Becker delivers the perfect mix of fun and tradition.

Paper; 192 pages; 6½ x 7½
Full-color
\$16.95 US
ISBN 978-1-63586-294-2

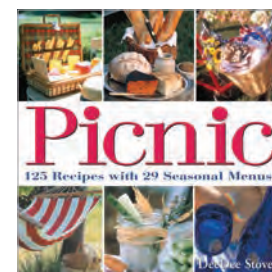

Picnic

DEEDEE STOVEL

These 125 recipes for packable, portable fare are for anyone who finds that food tastes better in the great outdoors. Menus themed by season and occasion cover all picnicking possibilities, from informal to elegant.

■ **162,000 COPIES IN PRINT**
Paper; 192 pages; 8 x 8
Two-color
\$10.95 US
ISBN 978-1-58017-377-3



Cooking with Fire

PAULA MARCOUX

Roma-style bacon on a green-wood stick, roasted pork loin on a spit, seared scallops on a griddle, Plymouth fish chowder in a cast-iron pot, turkey in a smoker, and baguettes in a wood-fired oven are just a few of the dishes that can be made with live-fire cooking.

Paper with flaps; 320 pages; 8 x 10
Full-color
\$22.95 US
ISBN 978-1-61212-158-1



Hot Sauce!

JENNIFER TRAINER THOMPSON

Here are 32 recipes for signature sauces, from the sweet-tart Pomegranate Narsharab to the super-spicy She Simmers, plus 60 recipes for using them in everything from barbecue to bouillabaisse.

■ **71,000 COPIES IN PRINT**
Paper; 192 pages; 6½ x 8½
Full-color
\$14.95 US
ISBN 978-1-60342-816-3





“Required reading for any cook looking for inventive, creative ways to prepare food in a small space.”

—Diane Phillips, author of *Perfect Party Food*

The Tiny Kitchen Cookbook

ANNIE MAHLE

Chef Annie Mahle shares her small-space cooking strategies and 50 of her favorite recipes she developed as the galley chef aboard the J&E Riggin. From versatile breakfast options to one-bowl salads and mains, stovetop meals, dishes that can be prepared in the toaster oven, and even make-ahead desserts in a mug, every recipe is delicious and utterly attainable in a kitchen with as little as six square feet of counter space. Along with gorgeous recipes, Mahle delivers tips and techniques for making the most of a small kitchen.

Paper; 224 pages; 7 x 8
Full-color
\$19.95 US
ISBN 978-1-63586-287-4



Fresh Flavors for the Slow Cooker

NICKI SIZEMORE

This fresh spin on slow-cooker meals replaces canned ingredients with fresh vegetables, boosts flavor with aromatic herbs and spices, and features a tantalizing array of global tastes in dishes that span the menu. Thirty-five recipes highlight do-ahead prep work, making serving meals worthy of every occasion easy and delicious.

Paper; 208 pages; 8 x 9
Full-color
\$18.95 US
ISBN 978-1-63586-123-5

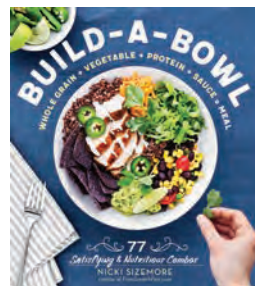

Build-a-Bowl

NICKI SIZEMORE

Food writer Nicki Sizemore’s fuss-free formula for creating delicious, satisfying grain bowls begins with a grain base followed by fresh vegetables and herbs, a lean protein, and a flavorful sauce. With 77 creative, customizable bowl combinations, these nutrition-packed meals work for breakfast, lunch, or dinner.

Paper; 192 pages; 8 x 9
Full-color
\$18.99 US
ISBN 978-1-61212-990-7

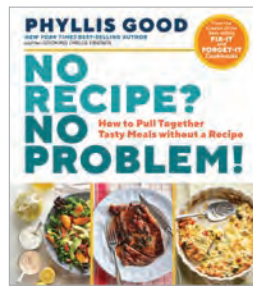

No Recipe? No Problem!

PHYLLIS GOOD

Phyllis Good, creator of the best-selling Fix-It and Forget-It series, empowers home cooks of all levels with the confidence and know-how to create delicious meals, offering advice for cooking with what’s in the fridge, saving money and time, and dishing up food to any family’s tastes.

Paper; 352 pages; 8 x 9
Full-color
\$19.95 US
ISBN 978-1-63586-258-4



Strawberry Love

CYNTHIA GRAUBART

Celebrate strawberry season with 45 recipes for enjoying this heavenly fruit, fresh or frozen. With sweet and savory recipes that span the menu, strawberry lovers will find tantalizing new ways—along with the classics—to make the most of their summer berry bounty.

Paper with flaps; 104 pages; 7 x 9
Full-color
\$12.95 US
ISBN 978-1-63586-322-2



Blueberry Love

CYNTHIA GRAUBART

Prized for their taste and nutrition, blueberries are a favorite for eating by the handful and as an ingredient in cooking and baking. *Blueberry Love* celebrates this sweet-tart summer fruit with 46 recipes for enjoying blueberries, fresh or frozen.

Paper with flaps; 104 pages; 7 x 9
Full-color
\$12.95 US
ISBN 978-1-63586-310-9



Zucchini Love

CYNTHIA GRAUBART

James Beard Award-winning cookbook author Cynthia Graubart brings her passion for producing veggie-forward family meals to over 40 recipes. Mouthwatering full-color photos and step-by-step instructions accompany each recipe—plus there are tips for picking, freezing, and preserving—making the book easy to use and highly browsable.

Paper; 104 pages; 7 x 9
Full-color
\$14.99 US
ISBN 978-1-63586-615-5



“There are so many creative, mouthwatering winners here, it’s hard to know where to start.”

—Jenna Helwig, food director at *Real Simple* and author of *Bare Minimum Dinners*

Tomato Love

JOY HOWARD

A mouthwatering collection of recipes for tomato lovers, featuring a combination of familiar favorites and new flavor combinations, with a photograph of every recipe and options for using either fresh-picked or canned tomatoes for year-long enjoyment. New takes on classic dishes like red sauce and tomato soup, along with a mix of fresh ideas ranging from Sweet, Spicy, Smoky Barbecue Sauce, and Shakshuka with Extra Veg. *Tomato Love* is a joyful collection of recipes that celebrate the favorite high-summer fruit.

Paper; 104 pages; 7 x 9
Full-color
\$14.95 US
ISBN 978-1-63586-467-0



The Apple Cookbook, 3rd Edition

OLWEN WOODIER

Apples take top billing in more than 125 sweet and savory recipes—30 of them new to this edition. Apples enhance everything from soups and salads to entrées and desserts, including Apple, Sausage, and Cheese Strata; Ground Lamb Kebabs with Apple Mint Raita; and Almond Apple Streusel.

Paper; 240 pages; 7 x 9
Full-color
\$16.99 US
ISBN 978-1-61212-518-3

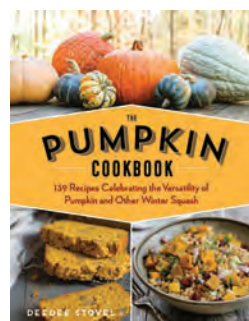

The Pumpkin Cookbook, 2nd Edition

DEEDEE STOVEL

These 139 recipes—including Currant-Pumpkin-Oat Scones, Chicken-Pumpkin Tacos, and, of course, pies—span the menu and the globe, showing off pumpkin’s year-round versatility and highlighting options for substituting other winter squash, from butternut to kabocha.

Paper; 248 pages; 7 x 9
Full-color
\$18.99 US
ISBN 978-1-61212-833-7



Maple Syrup Cookbook, 3rd Edition

KEN HAEDRICH

This sweet classic features abundant breakfast and dessert recipes, while savory lunch and dinner entrées offer unexpected uses for pure maple syrup. Tidbits on maple sugaring traditions, preparation tips, and profiles of farmers capture the country romance of the syrup-making process.

Paper; 192 pages; 7 x 9
Full-color
\$14.99 US
ISBN 978-1-61212-664-7

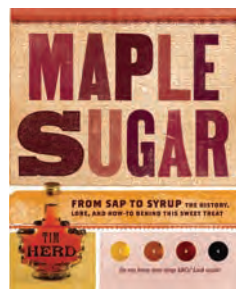

Maple Sugar

TIM HERD

Readers will savor the history of maple sugaring, learn to identify various kinds of maple trees, discover how to tap trees and make syrup, and indulge in tempting recipes for such treats as maple bread and pecan pie.

Paper; 144 pages; 6½ x 7½
Full-color
\$12.95 US
ISBN 978-1-60342-735-7

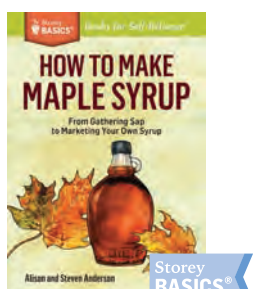

How to Make Maple Syrup

ALISON & STEVEN ANDERSON

Whether using containers or a tree-friendly tubing system, readers learn how to tap maple trees, collect and boil the sap, and bottle the finished syrup. For those interested in making syrup for fun or as a business, this handy resource includes everything needed to understand the production process.

Paper; 128 pages; 5 x 7
Illustrations throughout
\$9.99 US
ISBN 978-1-61212-171-0



The Classic Zucchini Cookbook

NANCY C. RALSTON, MARYNOR JORDAN & ANDREA CHESMAN

Taking zucchini beyond bread is a breeze with 225 recipes for using summer and sweet winter squash varieties in everything from soups and salads to satisfying mains and decadent desserts.

■ **496,000 COPIES IN PRINT**
Paper; 320 pages; 8 x 8½
Two-color
\$18.95 US
ISBN 978-1-58017-453-4

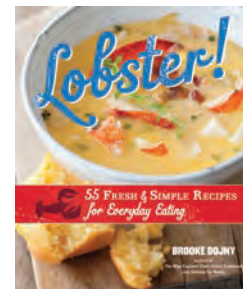

Lobster!

BROOKE DOJNY

Prized for its delicate flavor and satisfying, meaty texture, lobster is also a surprisingly affordable luxury. From lobster-based appetizers, stews, and mains to tasty accompanying side dishes and desserts, lobster-loving home cooks will find everything they need in these 55 recipes.

Hardcover; 144 pages; 6½ x 8
Full-color
\$14.95 US
ISBN 978-1-60342-962-7



Chowderland

BROOKE DOJNY

From Boston-Style Creamy Clam Chowder to Portuguese Caldo Verde Chowder, all good chowders have this in common: they taste amazing! Here are 50 recipes for the classic one-pot dish that everyone loves to eat, plus accompanying side dishes, salads, and desserts.

Hardcover; 144 pages; 6½ x 8
Full-color
\$17.00 US
ISBN 978-1-61212-375-2



“I can feel the love and tenderness chef and beekeeper Laurey has for her hives in every mindful word, every glorious photo, and lastly, every delicious, mouth-watering recipe.”

—Virginia Willis, Chef and author of *Bon Appetit, Y’all*

The Fresh Honey Cookbook

LAUREY MASTERTON

With 84 recipes that highlight a different honey varietal for each month of the year, author Laurey Masterton showcases the versatility of this incomparable natural sweetener. Masterton’s recipes include how to use avocado honey to add depth to April’s baby carrots; spice up July peaches with sourwood honey; and add some cranberry honey to November’s Thanksgiving spread. This delightful book is filled with bits of honey lore and beekeeping history to sweeten the exploration of the varied and delicious ways to use honey every day.

Paper; 208 pages; 7 x 9
Full-color
\$16.99 US
ISBN 978-1-61212-051-5

BEST-SELLING AUTHORS KIRSTEN K. SHOCKEY & CHRISTOPHER SHOCKEY



Homebrewed Vinegar

KIRSTEN K. SHOCKEY

Covering vinegar science and brewing basics—along with methods and recipes for fermenting vinegars using everything from wine and cider to flowers, fruits, and vegetables—*Homebrewed Vinegar* is the go-to vinegar fermentation guide.

Paper; 296 pages; 7 x 9
Full-color
\$22.99 US
ISBN 978-1-63586-281-2

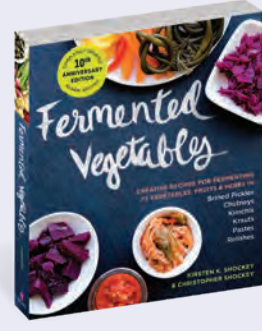

Fermented Vegetables, 10th Anniversary edition

Prized for their health benefits and powerful flavor punch, fermented foods such as kimchi, sauerkraut, pickles, chutneys, and pastes are enjoyed worldwide. This comprehensive guide includes 140 unique recipes for fermenting more than 80 vegetables, as well as 84 recipes for using them in meals and snacks.

Paper; 376 pages; 8 x 9
Full-color
\$27.99 US
ISBN 978-1-63586-539-4



Fiery Ferments

Fans of fermentation can expand their repertoire with more than 70 recipes for gut-healthy hot sauces, mustards, pickles, chutneys, relishes, and kimchis from around the globe. An additional 40 recipes highlight many uses for the hot ferments.

Paper; 272 pages; 8 x 9
Full-color
\$24.95 US
ISBN 978-1-61212-728-6



Miso, Tempeh, Natto & Other Tasty Ferments

Following step-by-step photography and instructions, home cooks can make flavor-packed, probiotic-rich foods that have long been staples in Asian cooking in their own kitchens. In addition to using traditional ingredients, readers will create ferments with chickpeas, lentils, quinoa, and more, and find recipes for using ferments in cooking.

Paper; 408 pages; 8 x 10
Full-color
\$29.99 US
ISBN 978-1-61212-988-4



The Big Book of Cidermaking

With expert advice and clear, step-by-step instructions, this comprehensive guide equips cidermakers of all levels with the skills to make the cider they want—wild or cultivated, still, bubbly, sweet, dry, fruity, farmhouse-style, hopped, barrel-aged, or fortified.

Paper; 336 pages; 8 x 9
Full-color
\$29.99 US
ISBN 978-1-63586-113-6



Put 'em Up!

SHERRI BROOKS VINTON

These simple instructions and delicious recipes for everything from applesauce to zucchini pickles cover refrigerating, freezing, drying, canning, and pickling.

Paper; 304 pages; 7 1/2 x 9 1/2
Full-color
\$22.95 US
ISBN 978-1-60342-546-9

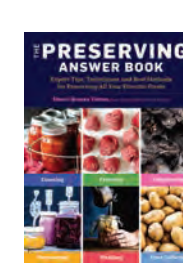

The Preserving Answer Book

SHERRI BROOKS VINTON

The must-have companion to every preserving recipe book, this comprehensive reference answers all the questions that arise in the fruit or vegetable preserver's kitchen.

Paper; 256 pages; 6 x 8
Two-color
\$14.95 US
ISBN 978-1-63586-420-5

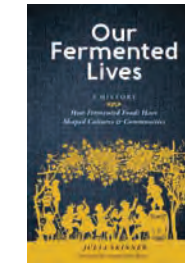

Our Fermented Lives

JULIA SKINNER

Food historian Julia Skinner takes a deep dive into the cultural history of fermented foods, examining how bread, coffee, tea, alcoholic drinks, vinegars, fermented vegetables, herbs, and spices were first introduced and their inextricable connection to the evolution of human health, food tastes and preservation techniques.

Hardcover; 384 pages; 6 x 9
Two-color; illustrations throughout
\$30.00 US
ISBN 978-1-63586-383-3

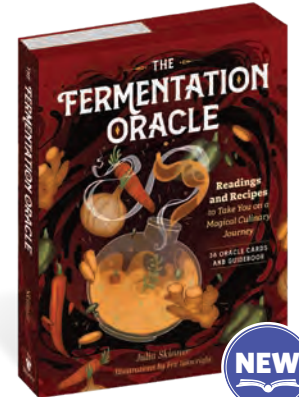

“Unlock the potential of mindful fermentation.”

—Courtney Burns, chef, seeker, and author of *Nourish Me Home*

The Fermentation Oracle

JULIA SKINNER

In *The Fermentation Oracle*, author Julia Skinner opens a portal to new culinary and personal explorations by sharing 36 guided meditations on the properties of each ferment, intended to help you think creatively about the gifts of that particular food or drink, access intuition, and navigate each day's joys and problems more thoughtfully. The book is packaged with a deck of 36 lavishly illustrated oracle cards to spark your next culinary adventure and 38 creative recipes inspired by the readings that accompany them.

Hardcover with 36 cards and guidebook; 120 pages
Full-color
\$28.00 US
ISBN 978-1-63586-832-6

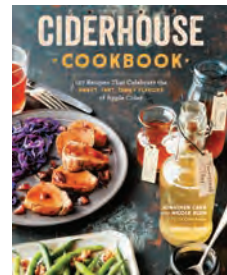

Ciderhouse Cookbook

JONATHAN CARR, NICOLE BLUM & ANDREA BLUM

In this lushly photographed cookbook, artisanal cidermakers Jonathan Carr and Nicole Blum of Carr's Ciderhouse teach home cooks to make an array of traditional apple cider products such as cider syrups, molasses, vinegars, switchels, and apple preserves. Includes 127 simple yet elegant cider-enriched recipes.

Paper with flaps; 232 pages; 8 x 10
Full-color
\$19.95 US
ISBN 978-1-61212-940-2



Making & Using Vinegar

BILL COLLINS

Readers will not only learn how to make basic vinegars—including wine, apple cider, malt, white, and rice—but will also gain an understanding of the versatility of this essential kitchen ingredient with instructions for cooking with it and for flavoring it with herbs.

Paper; 96 pages; 5 x 7
Illustrations throughout
\$9.99 US
ISBN 978-1-61212-381-3



Herb Mixtures & Spicy Blends

MAGGIE OSTER

Gathered from herb shops and herb farms across North America, here are more than 100 recipes for making and using spice rubs and herb blends to flavor foods without adding fat or calories.

Paper; 160 pages; 7 1/2 x 9 1/2
Illustrations throughout
\$14.95 US
ISBN 978-0-88266-918-2

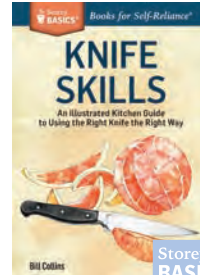

Knife Skills

BILL COLLINS

Good knife skills are key to feeling comfortable in the kitchen. Readers learn how to pick out knives that fit the hand and how to slice, chop, peel, bone, and dice with ease. Step-by-step instructions and illustrations also show how to cut and carve seafood, poultry, meats, fruits, and vegetables.

Paper; 112 pages; 5 x 7
Illustrations throughout
\$9.95 US
ISBN 978-1-61212-379-0



Preserving Wild Foods

MATTHEW WEINGARTEN & RAQUEL PELZEL

Dozens of inspired recipes show how to preserve a wide range of wild ingredients foraged from the sea, fields, forests, and fresh water and how to use them to make such delicacies as salt cod fritters, sea-hip jam, black walnut liqueur, and duck prosciutto.

Paper with flaps; 256 pages; 7 1/2 x 9 1/2
Full-color
\$19.95 US
ISBN 978-1-60342-727-2

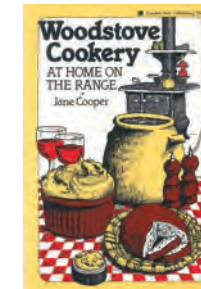

Woodstove Cookery

JANE COOPER

Offering advice on everything from cleaning to cooking on and in woodstoves, this book demonstrates how to get more use out of this versatile heat source. Descriptions of the necessary techniques and recommended cookware accompany time-tested recipes for every meal.

■ **101,000 COPIES IN PRINT**
Paper; 208 pages; 6 x 9
Illustrations throughout
\$16.99 US
ISBN 978-0-88266-108-7

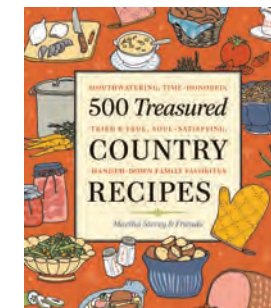

500 Treasured Country Recipes

MARTHA STOREY & FRIENDS

This heirloom cookbook is a treasure trove of simple recipes with old-fashioned heart, with family favorites that never go out of style, from classic bread-and-butter pickles to hand-churned ice cream.

■ **90,000 COPIES IN PRINT**
Paper; 544 pages; 8 x 9 1/2
Two-color
\$18.95 US
ISBN 978-1-58017-291-2

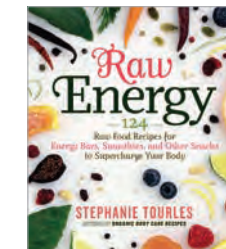

Raw Energy

STEPHANIE TOURLES

These 124 nutrition-packed recipes for trail mixes, soups, chips, dips, cookies, and more are all made with unprocessed whole foods such as nuts, seeds, fruits, vegetables, carob, cocoa, and fresh juices.

■ **64,000 COPIES IN PRINT**
Paper; 272 pages; 6 1/2 x 7 1/2
Full-color
\$16.95 US
ISBN 978-1-60342-467-7



Raw Energy in a Glass

STEPHANIE TOURLES

More than 120 super-nutritious, super-delicious recipes for smoothies, shakes, green drinks, power shots, mocktails, longevity elixirs, and fermented beverages are all designed to boost health and energy.

Paper; 288 pages; 6 1/2 x 7 1/2
Full-color
\$16.95 US
ISBN 978-1-61212-248-9



Recipes from the Herbalist's Kitchen

BRITTANY WOOD NICKERSON

This unique cookbook reveals food as a powerful source of medicine, with detailed profiles of favorite culinary herbs. Generous portions of these herbs are then used in the 110 recipes for snacks, entrées, drinks, and desserts that meet the body's needs for comfort, nourishment, energy, and support through seasonal changes.

■ IACP Award Finalist
■ Gold Foreword INDIES Award
■ Silver Nautilus Award

Hardcover; 312 pages; 8 x 10
Full-color
\$30.00 US
ISBN 978-1-61212-690-6

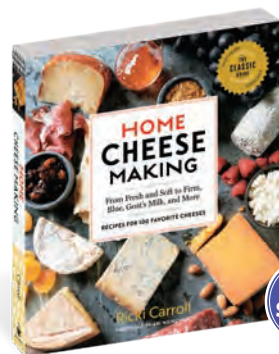

“Without a doubt, this is the homemade cheese resource I recommend the most.”

—Jill Winger, author of *The Prairie Homestead Cookbook*

BEST SELLER

Home Cheese Making, 4th Edition

RICKI CARROLL

The completely updated handbook for the home cheesemaker features 35 new cheese recipes, color photography of step-by-step techniques, and new profiles of contemporary cheesemakers.

The additions to this comprehensive volume reflect the broader selection of cheeses available in specialty food stores and groceries, including burrata, stracchino, Brillat-Savarin, D’Affinois, Cambrales, Drunk Gouda, Pecorino Pepato, goat milk’s gouda, and more. Companion recipes are included for cheese plate condiments and classic cheese dishes.

Paper; 384 pages; 8 x 9
Full-color
\$24.99 US
ISBN 978-1-61212-867-2



Homemade Yogurt & Kefir

GIANACIS CALDWELL

This foundational guide teaches the art of making probiotic-rich yogurt and kefir at home. Readers will master the basics like making simple cheeses, butter, and whipped cream cultured with yogurt and kefir—then branch out with creative recipes for using fermented dairy products in dishes, including sauces, soups, and even cocktails!

Paper; 224 pages; 7 x 9
Full-color
\$19.95 US
ISBN 978-1-63586-109-9



The Home Creamery

KATHY FARRELL-KINGSLEY

Step-by-step instructions guide readers through recipes for more than a dozen fresh and cultured dairy products, and 75 cooking and baking recipes showcase homemade dairy items.

Paper; 220 pages; 7 x 9
Two-color
\$18.99 US
ISBN 978-1-60342-031-0

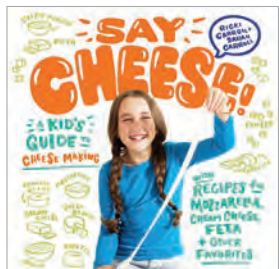

Say Cheese!

RICKI CARROLL & SARAH CARROLL

Making cheese at home is easy, and this fun guide shows families how. Step-by-step photos take kids through the cheesemaking process and teach them how to make 10 of their favorites, including mozzarella, feta, ricotta, and cream cheese.

■ For ages 8–12

Paper with concealed wire-o and 4 sticker sheets; 136 pages; 9 x 9½
Full-color
\$18.95 US
ISBN 978-1-61212-823-8

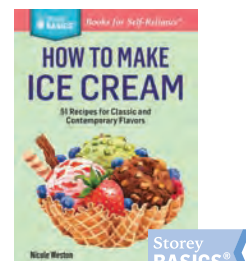

How to Make Ice Cream

NICOLE WESTON

From Rocky Road to Roasted Fig and Honey, ice cream lovers will delight in creating classic and contemporary flavors at home, with 51 recipes for both custard-based ice creams and lighter eggless options.

Paper; 96 pages; 5 x 7
Illustrations throughout
\$8.95 US
ISBN 978-1-61212-388-2



Perfectly Creamy Frozen Yogurt

NICOLE WESTON

Following step-by-step instructions and 56 yogurt recipes, fans can make flavors that range from traditional to artisanal, and an additional 50 recipes offer ideas for using homemade frozen yogurt in cakes, cookie sandwiches, and frozen pops.

Paper; 176 pages; 7 x 9
Full-color
\$16.95 US
ISBN 978-1-61212-880-1

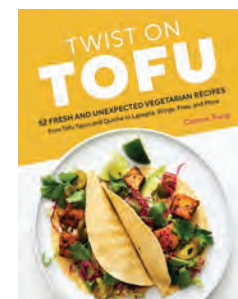

Twist on Tofu

CORINNE TRANG

Award-winning cookbook author Corinne Trang puts a fresh twist on tofu, the budget-friendly, high-protein meat alternative, and shows off its versatility with 52 fresh and appealing recipes, ranging from tofu versions of French fries, wings, and tacos, to hearty chili, quiche, and curry, and even sweet treats like tofu mocha brownies.

Paper; 128 pages; 7 x 9
Full-color
\$16.99 US
ISBN 978-1-63586-481-6



“If you’re looking to create a healthier home food supply and save money in the process, this is your book!”

—Jill Winger, author of *The Prairie Homestead Cookbook*

BEST SELLER

Freeze Fresh

CRYSTAL SCHMIDT

An in-depth guide to the easiest and most economical way to preserve homegrown or locally grown produce—in the freezer! Techniques and tips for more than 55 popular fruits and vegetables are featured along with 100 recipes that freeze well and use previously frozen produce to best advantage. Author Crystal Schmidt shares her time-tested preparation techniques that ensure color, texture, and flavor are retained. Home cooks and gardeners alike will love discovering how easy and economical it can be to fill your freezer with produce customized to your own tastes.

■ **72,000 COPIES IN PRINT**

Paper; 208 pages; 8 x 9
Full-color
\$19.99 US
ISBN 978-1-63586-447-2



Instant Pot Cheese

CLAUDIA LUCERO

This foolproof guide offers recipes for making a wide variety of cheeses and even dairy-free cheese alternatives using this beloved countertop appliance. Readers learn to make classics including paneer, ricotta, goat cheese, and easy cottage cheese as well as more sophisticated options like burrata and feta.

Paper; 144 pages; 7 x 9
Full-color
\$16.95 US
ISBN 978-1-63586-240-9

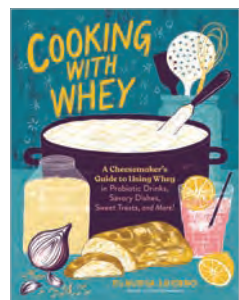

Cooking with Whey

CLAUDIA LUCERO

Popular cheesemaking author Claudia Lucero shares 60 inventive recipes that use whey, a nutrient-rich byproduct that too often goes to waste in the making of cheese, yogurt, and kefir. Mouth-watering recipes for beverages, soups, breads, desserts, and everyday meals are included in this book showcasing a delightfully surprising array of ways to put whey to work.

Paper; 128 pages; 7 x 9
Full-color
\$16.99 US
ISBN 978-1-63586-263-8

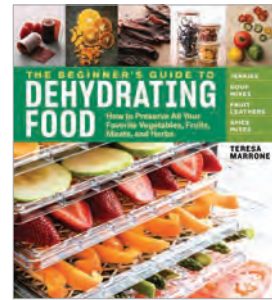

The Beginner's Guide to Dehydrating Food, 2nd Edition

TERESA MARRONE

Stocking the pantry with dried foods is easy and economical with this friendly, full-color reference. Create dried vegetables, fruits, herbs, jerky, and more with instructions for using a tabletop dehydrator, convection oven, or the power of the sun.

Paper; 320 pages; 8 x 9
Full-color
\$24.95 US
ISBN 978-1-63586-024-5

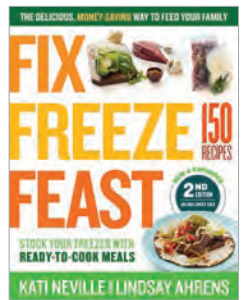

Fix, Freeze, Feast, 2nd Edition

KATI NEVILLE & LINDSAY AHRENS

Fill the freezer with healthy, ready-to-cook meals! The second edition of this best-selling book offers busy, thrifty home cooks 150 recipes updated to incorporate more plant-based meals; fresh, seasonal produce; and healthy grains and beans.

Paper; 256 pages; 7 x 9
Full-color
\$18.95 US
ISBN 978-1-61212-928-0



The Make-Ahead Sauce Solution

ELISABETH BAILEY

Transform ordinary dinner staples like chicken breast, plain pasta, or a basic baked potato into delicious week-night meals with recipes for 61 flavor-packed sauces that can be made in advance and stored in the freezer. Quick-reference charts show a range of satisfying meal options for each sauce.

Paper; 200 pages; 7 x 9
Full-color
\$16.95 US
ISBN 978-1-61212-959-4



Cured Meat, Smoked Fish & Pickled Eggs

KAREN SOLOMON

This accessible guide teaches preserving enthusiasts to smoke, pickle, salt-cure, oil-cure, and dehydrate meats, dairy, fish, eggs, and other proteins. Creative recipes highlight the range of specialty foods that can be made at home.

Paper; 200 pages; 7 x 9
Full-color
\$19.95 US
ISBN 978-1-61212-903-7



A Guide to Canning, Freezing, Curing & Smoking Meat, Fish & Game

WILBUR F. EASTMAN JR.

With dozens of recipes for bacon, corned beef, jerky, pepperoni, and more, this no-nonsense guide is an excellent resource for preserving and storing meat.

Paper; 240 pages; 6 x 9
Illustrations throughout
\$16.95 US
ISBN 978-1-58017-457-2

BEST SELLER



Smokehouse Handbook

JAKE LEVIN

This one-stop reference equips fans of grilling and live-fire cooking with everything they need to achieve flawless smoked meat, poultry, seafood, and more. From choosing the right variables for superior flavor and texture to smoking techniques, equipment overviews, and building plans for a multipurpose smokehouse, this go-to guide covers it all.

Hardcover; 200 pages; 8 x 10
Full-color
\$24.95 US
ISBN 978-1-63586-011-5



“This book leaves out no one, even providing vegetarian options, including bean- and tofu-based meatless sausages.”

—Booklist

BEST SELLER

Home Sausage Making, 4th Edition

CHARLES G. REAVIS & EVELYN BATTAGLIA WITH MARY REILLY

Home Sausage Making is the most comprehensive go-to reference on the subject. The re-designed fourth edition is better than ever, with 100 recipes and the most current guidelines for popular charcuterie techniques such as dry curing and smoking.

Step-by-step photos make the process accessible for all levels. Cooks learn to make breakfast sausage and global favorites like mortadella, liverwurst, chorizo, salami, kielbasa, and bratwurst—and recipes for using wild game, chicken, seafood, and vegetables ensure there’s something for every taste.

Paper; 376 pages; 8 x 9
Full-color
\$24.99 US
ISBN 978-1-61212-869-6

Hardcover; \$35.00 US
ISBN 978-1-61212-985-3

BEST-SELLING AUTHOR ANDREA CHESMAN

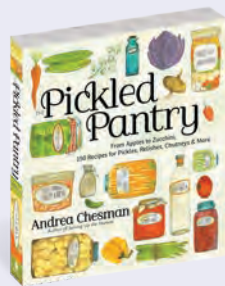

The Pickled Pantry

This fresh, contemporary guide to pickling provides a whopping 150 recipes for putting up everything from apples to zucchini, plus 36 recipes for cooking with pickled foods. It includes techniques for making fermented pickles, salsas, relishes, and chutneys.

■ **148,000 COPIES IN PRINT**

Paper; 304 pages; 8 x 9
Full-color
\$22.99 US
ISBN 978-1-60342-562-9

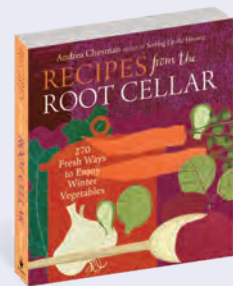

Recipes from the Root Cellar

Sweet winter squashes, hardy greens, jewel-toned root vegetables, and potatoes of every kind are just some of the staples of delicious cold weather fare. This collection of more than 250 recipes brings local produce to the winter table.

Paper; 400 pages; 8 x 9
Two-color
\$18.95 US
ISBN 978-1-60342-545-2

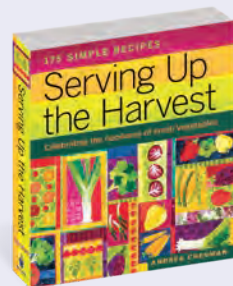

Serving Up the Harvest

This collection of 175 recipes helps garden-fresh vegetables shine. Fourteen additional master recipes show readers how to easily accommodate whatever is especially bountiful in their produce basket.

Paper; 512 pages; 8 x 9
Two-color
\$18.95 US
ISBN 978-1-58017-663-7



101 One-Dish Dinners

Serving up a balanced meal doesn't need to be complicated! In this collection of 101 recipes, classic baked fare like chicken pot pie and vegetable lasagna share the table with diverse stovetop suppers like jambalaya and pad Thai, plus plenty of meal-in-a-bowl salads and timeless soups.

Paper; 192 pages; 7 x 9
Full-color
\$16.95 US
ISBN 978-1-61212-841-2



The Fat Kitchen

With this comprehensive guide, cooks will learn the distinctive qualities and best uses for whole animal fats and methods for curing and storing them. In addition, 100 recipes highlight traditional cultural favorites like matzoh ball soup and Southern-style collards.

Paper; 304 pages; 8 x 9
Full-color
\$24.95 US
ISBN 978-1-61212-913-6

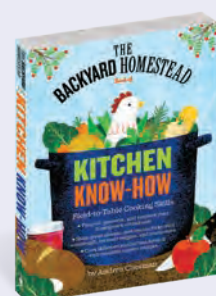

The Backyard Homestead Book of Kitchen Know-How

From milling flour to curing sausage, and from freezing or drying vegetables to preserving fruits, this go-to handbook teaches everything farm-fresh food enthusiasts need to know.

Paper; 368 pages; 7 x 9
Two-color
\$21.99 US
ISBN 978-1-61212-204-5

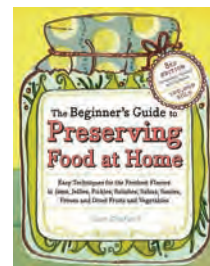

The Beginner's Guide to Preserving Food at Home

Discover the best and quickest methods for preserving every common vegetable and fruit, arranged in a friendly food-by-food format. Readers will find thorough instructions for freezing, drying, canning, brining, and storage.

Paper; 240 pages; 7 x 9
Two-color
\$14.99 US
ISBN 978-1-60342-145-4

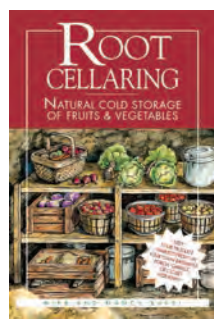

Root Cellaring

The earth's naturally cool, stable temperature is an energy-saving way to store nearly 100 varieties of fruits and vegetables all year long. The authors include specific storage requirements for each crop and building instructions for big and small root cellars.

■ **222,000 COPIES IN PRINT**
Paper; 320 pages; 6 x 9
Photographs and illustrations throughout
\$16.99 US
ISBN 978-0-88266-703-4

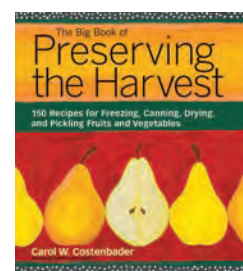

The Big Book of Preserving the Harvest

This classic primer on drying, freezing, canning, and pickling includes more than 150 simple recipes.

Paper; 352 pages; 8 x 9
Two-color
\$19.99 US
ISBN 978-1-58017-458-9

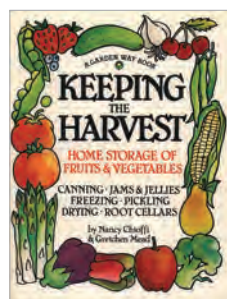

Keeping the Harvest

This classic guide presents simple yet satisfying home preserving techniques—including brining, canning, curing, drying, freezing, pickling, and more—so that readers can enjoy their freshly harvested fruits and vegetables all year long.

Paper; 208 pages; 8½ x 11
Illustrations throughout
\$16.99 US
ISBN 978-0-88266-650-1



Bread Making: A Home Course

Even beginners can successfully bake their own bread with this in-depth course in core bread-making techniques. From choosing flour to measuring, kneading, proofing, shaping, storing, and slicing, here is everything home bakers need to know to make artisanal loaves of every style.

Paper; 296 pages; 7 x 9
Two-color
\$16.95 US
ISBN 978-1-60342-791-3



101 Perfect Chocolate Chip Cookies

With 101 variations to choose from, this curated collection of recipes covers all the chocolate chip cookie bases, from crispy and chewy to healthful and the thoroughly unconventional—plus tips for baking and storage.

Paper; 144 pages; 8 x 8
Two-color
\$10.95 US
ISBN 978-1-58017-312-4



The Harvest Baker

Award-winning author Ken Haedrich's novel take on baking presents 150 creative and delicious ways to use garden-fresh fruits, veggies, and herbs in baked goods that go far beyond zucchini bread and carrot cake. Dishes range from savory quiches, tarts, and pot pies to pizzas, calzones, hearty yeast breads and buns, muffins, and scones. And don't forget the sweet cakes, pies, and cookies!

Paper with flaps; 304 pages; 8 x 10½
Full-color
\$19.95 US
ISBN 978-1-61212-767-5



How to Make Chocolate Candies

Aspiring confectioners will learn easy techniques for tempering chocolate, working with thickeners, boiling sugar, using piping bags, and filling molded chocolates to make truffles, nut barks, shaped candies, chocolate-covered fruits, and fudge.

Paper; 96 pages; 5 x 7
Illustrations throughout
\$8.95 US
ISBN 978-1-61212-357-8

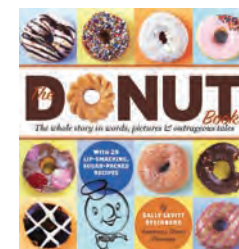

The Donut Book

This pop culture-filled tribute to America's favorite coffee companion explores the donut's rich history, lore, mythology, and philosophy, from the origins of the donut hole to profiles of mom-and-pop donut shops and the global ascent of Krispy Kreme. Includes 28 scrumptious recipes.

■ **40,000 COPIES IN PRINT**
Paper; 192 pages; 8 x 8½
Full-color
\$14.95 US
ISBN 978-1-58017-548-7



Bean-to-Bar Chocolate

Chocoloholics are invited on a fascinating journey through America's craft chocolate revolution. Along with tasting guidelines, readers learn the nuances of pairing chocolate with coffee, beer, spirits, cheese, and bread.

■ The Gourmand World Cookbook Awards US winner, Chocolate category
Hardcover; 240 pages; 6½ x 8
Full-color
\$19.95 US
ISBN 978-1-61212-821-4

"An excellent resource for home bakers looking to up their pie game."

—Publishers Weekly, starred review



Pie Academy

In this master class on pie baking, the founder of The Pie Academy serves up step-by-step instructions for achieving truly great pie. Bakers of all levels will learn to make every kind of pie pastry and style imaginable, as well as an incredible assortment of fillings.

With 255 recipes ranging from classic apple pie and pumpkin pie to summer berry, fruit, nut, custard, chiffon, and cream pies, freezer pies, slab pies, hand pies, and turnovers, *Pie Academy* serves up forty years of pie wisdom in a single, satisfying package.

Hardcover; 480 pages; 8 x 10½
Full-color
\$35.00 US
ISBN 978-1-63586-111-2



Lattice Topping Technique



Pumpkin-Praline Pie



Fried Peach Pie



Kahlúa Fudge Brownie Pie

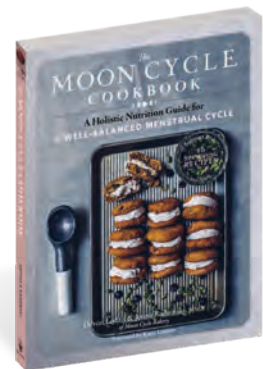

“A must-have if you want to understand how and what to eat according to the phases of your menstrual cycle.”

—Nicole Jardim, Certified Women's Health Coach
Author of *Fix Your Period*

The Moon Cycle Cookbook

DEVON LOFTUS & JENNA RADOMSKI, MSCN

Moon Cycle bakery founder Devon Loftus and nutritionist Jenna Radomski empower women to nourish themselves with recipes for sweets, savory meals, and snacks, organized around each phase of the menstrual cycle. Every recipe is formulated with the knowledge of what is happening hormonally in a woman's body during each cycle phase, using ingredients that replenish and support essential nutrients. A happy mix of creativity, self-empowerment, and downright deliciousness, this wellness guide demystifies menstrual health, educating readers about their unique needs and helping them to deepen their self-care regimen.

Paper; 240 pages; 6½ x 8½
Full-color
\$19.99 US
ISBN 978-1-63586-285-0

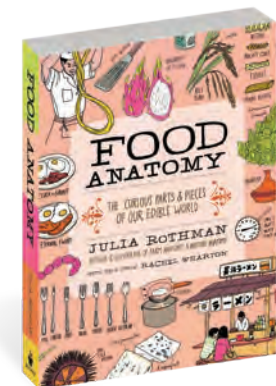

“The food encyclopedia meets the graphic novel in this knowledgeable basic introduction to all things edible.”

—Booklist

Food Anatomy

JULIA ROTHMAN

With an illustrated history of food, a hilarious primer on diner slang, and a mouthwatering menu of how people around the planet serve fried potatoes, readers get their recommended daily allowance of food facts and fun. Best-selling author and noted illustrator of *Nature Anatomy*, Julia Rothman takes her pen into the kitchen with this charming, illustrated guide to all things edible around the globe.

■ **70,000 COPIES IN PRINT**

Paper with flaps; 224 pages; 6½ x 9
Full-color
\$18.99 US
ISBN 978-1-61212-339-4

ALSO AVAILABLE:
Farm Anatomy, page 48
Nature Anatomy, page 48
Ocean Anatomy, page 48



Cookie Classics Made Easy

BRANDI SCALISE

Making cookies has never been so easy! These 41 no-fuss, one-bowl recipes include favorites like chewy chocolate chip, shortbread, and ginger molasses, plus soon-to-be classics like vanilla walnut pear and rum raisin.

Paper with flaps; 96 pages; 6½ x 7½
Full-color
\$10.95 US
ISBN 978-1-61212-688-3



Cookie Craft

VALERIE PETERSON & JANICE FRYER

Turn plain cookies into special-occasion treats with foolproof foundational dough recipes, tips for mastering decorating techniques, advice for creating icing color palettes, and tricks for freezing and shipping flawless cookie creations.

Paper; 168 pages; 7½ x 9
Full-color
\$14.95 US
ISBN 978-1-61212-559-6

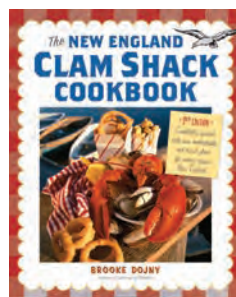

The New England Clam Shack Cookbook, 2nd Edition

BROOKE DOJNY

Taste the pride of New England with traditional coastal fare from 25 clam shacks, lobster pounds, and chowder houses. Nearly 100 mouthwatering recipes include lobster rolls, fried clams, savory chowders, and more. Traditional side dishes and classic Yankee desserts round out this collection.

Paper; 256 pages; 7½ x 9¼
Full-color
\$18.95 US
ISBN 978-1-60342-026-6

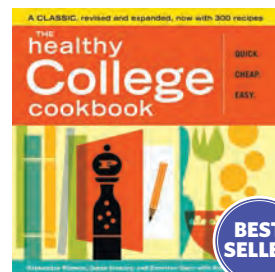

The Healthy College Cookbook

ALEXANDRA NIMETZ, JASON STANLEY & EMELINE STARR WITH RACHEL HOLCOMB

Busy students will love these tasty, nutritious recipes for quick-to-prepare soups, sandwiches, salads, and eat-on-the-go breakfasts—including dozens of vegetarian and vegan options.

Paper; 304 pages; 8 x 8
Two-color
\$14.95 US
ISBN 978-1-60342-030-3



Ghoulish Goodies

SHARON BOWERS

From Spiderweb Sugar Cookies to Cheddar Eyeballs, these 70 recipes for spooky sweets and scary savories pack plenty of visual punch and are perfect for Halloween events, kids' birthdays, movie nights, costume parties, and more.

■ **84,000 COPIES IN PRINT**
Paper; 160 pages; 7 x 8
Full-color
\$14.95 US
ISBN 978-1-60342-146-1



The Lake Michigan Cottage Cookbook

AMELIA LEVIN

This collection of 118 evocative recipes features favorite dishes from around the shores of Lake Michigan, including Helen Suchy's Apple Cake from Door County, Homemade Sheboygan-Style Bratwurst, The Cook's House Crispy Skinned Kale Trout from Traverse City, and more.

Paper; 288 pages; 7½ x 9¼
Full-color
\$19.95 US
ISBN 978-1-61212-732-3

BEST-SELLING SERIES DISHING UP®

226,000 COPIES IN PRINT



Dishing Up® New Jersey

JOHN HOLL

The Garden State's diversity shines through in these recipes, which feature the bounty of tomatoes, corn, and cranberries the state produces, along with boardwalk treats and late-night diner bites.

Paper; 288 pages; 7½ x 9¼
Full-color
\$19.95 US
ISBN 978-1-61212-666-1

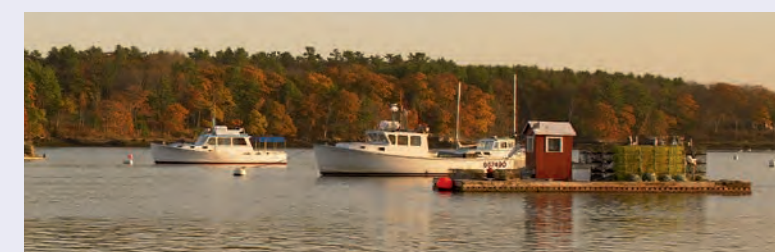

“Bingo! If a fried clam roll, a bowl of creamy lobster chowder, or a stack of wild blueberry pancakes rings your chimes, and you can't hop a jet, let Brooke Dojny 'dish it up' for you....authentic national treasures from the glorious state of Maine.” —Castine (ME) Patriot

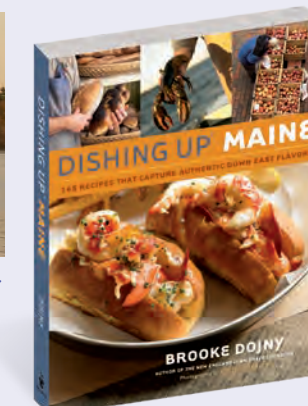

Dishing Up® Maine

BROOKE DOJNY

This collection of recipes from Maine's chefs, farmers, fishermen, and artisan producers serves up a heaping plate of classic and contemporary fare, from winter squash tacos to wild blueberry preserves, venison medallions to lobster pie.

■ **45,000 COPIES IN PRINT**

Paper; 288 pages; 7½ x 9¼
Full-color
\$19.95 US
ISBN 978-1-58017-841-9



Dishing Up® New Mexico

DAVE DEWITT

New Mexico's unique food culture takes center stage in recipes that feature the signature chile pepper, along with wild game and farm-raised meats, cheeses, nuts, and farm-fresh vegetables that highlight the Land of Enchantment's thriving agricultural tradition.

Paper; 288 pages; 7½ x 9¼
Full-color
\$19.95 US
ISBN 978-1-61212-250-2



Dishing Up® Virginia

PATRICK EVANS-HYLTON

Virginia is for food lovers, and the commonwealth's rich culinary legacy comes to life in recipes for everything from boiled peanuts and colonial crab cakes to country ham and pan-fried trout.

Paper; 288 pages; 7½ x 9¼
Full-color
\$19.95 US
ISBN 978-1-61212-002-7



Dishing Up® Washington

JESS THOMSON

From Pacific salmon and Dungeness crab to wild mushrooms, cherries, apples, saffron, and much more, these delectable recipes feature the bounty of fresh ingredients and vibrant flavors of the Evergreen State.

Paper; 288 pages; 7½ x 9¼
Full-color
\$24.99 US
ISBN 978-1-61212-028-7



Dishing Up® Maryland

LUCIE L. SNODGRASS

In Maryland cuisine, the crab reigns supreme, fritters and pies feature farm-fresh produce, and the towering Smith Island Cake looms large when it comes to dessert—and home cooks everywhere can enjoy it all.

■ **40,000 COPIES IN PRINT**

Paper; 288 pages; 7½ x 9¼
Full-color
\$19.95 US
ISBN 978-1-60342-527-8



Dishing Up® Minnesota

TERESA MARRONE

These recipes highlight the best of Minnesota's culinary traditions and fresh ingredients, including wild rice, freshwater fish, pure maple syrup, rich cheeses, and wild game—plus some time-less staples from the state fair!

Paper; 288 pages; 7½ x 9¼
Full-color
\$19.95 US
ISBN 978-1-61212-584-8

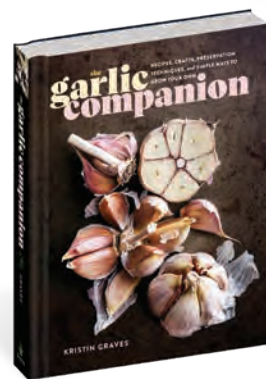

"If you love garlic, you need this book."

—Niki Jabbour, author of *The Year-Round Vegetable Gardener* and *Growing Under Cover*

The Garlic Companion

KRISTIN GRAVES

Author and garlic devotee Kristin Graves celebrates the wonderful world of this pungent herb, including how to plant, grow, harvest, and preserve it, as well as how to use both the bulbs and the scapes (flowering stems) in decorations and crafts such as garlic braids and wreaths. She has created 36 recipes that focus on using garlic in all its various forms—from Garlic Scape Refrigerator Pickles to Honey Garlic Ribs to Black Garlic Chocolate Chip Cookies—and offers dozens of ideas for celebrating the garlic harvest.

Hardcover; 224 pages; 7¼ x 9¼
Full-color
\$26.00 US
ISBN 978-1-63586-686-5



Healing Herbal Teas

SARAH FARR

Master herbalist Sarah Farr shares 101 original recipes for delicious herbal teas that benefit whole-body and seasonal health needs, along with guidance on the art of tea blending for readers seeking to develop their own signature mixtures.

Paper; 272 pages; 7½ x 7½
Full-color
\$17.99 US
ISBN 978-1-61212-574-9

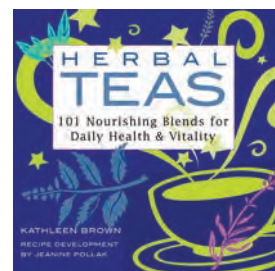

Herbal Teas

KATHLEEN BROWN

This guide to blending and brewing healthful herbal teas includes easy-to-make recipes and profiles of renowned herbalists who share their favorite blends. Readers will find teas for the digestive, respiratory, and nervous systems, skin, bones, joints, and more.

Paper; 160 pages; 7½ x 7½
Two-color
\$16.95 US
ISBN 978-1-58017-099-4



The Big Book of Cidermaking

CHRISTOPHER SHOCKEY & KIRSTEN K. SHOCKEY

The Big Book of Cidermaking is an empowering guide for every cidemaker, from the beginner seeking foundational techniques and tips to the intermediate cider crafter who wants to expand their skills.

Paper; 336 pages; 8 x 9
Full-color
\$29.99 US
ISBN 978-1-63586-113-6

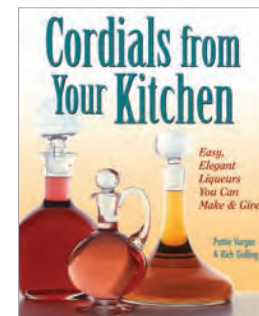

Cordials from Your Kitchen

PATTIE VARGAS & RICH GULLING

Home-crafted versions of popular favorites and delicious original concoctions are easy to make with more than 100 recipes for cordials to suit every occasion, including fruit-, nut-, herb-, and cream-based liqueurs, coffee liqueurs, and flavored brandies, vodkas, and rums.

■ **50,000 COPIES IN PRINT**

Paper; 176 pages; 7½ x 9¼
Two-color
\$14.95 US
ISBN 978-0-88266-986-1

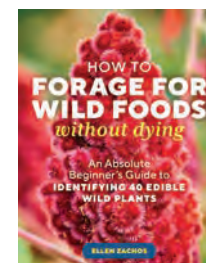

How to Forage For Wild Foods Without Dying

ELLEN ZACHOS

Zachos has curated the 40 most common, most delicious edible plants, ranging from black walnuts and juniper berries to elderflowers, wild garlic and many more. With Zachos's expert advice and easy-to-follow guidelines, readers will be confident in identifying which plants they can safely eat and which ones they should definitely avoid.

Paper; 256 pages; 5½ x 7
Full-color
\$16.99 US
ISBN 978-1-63586-613-1



The Wildcrafted Cocktail

ELLEN ZACHOS

Mixed drink enthusiasts learn to make more than 50 garnishes, syrups, juices, and bitters that use easily foraged ingredients, and how to incorporate their handcrafted cocktail components into 45 delicious beverages, such as Stinger in the Rye and Tree-tini.

Paper; 240 pages; 6½ x 8½
Full-color
\$14.95 US
ISBN 978-1-63586-416-8

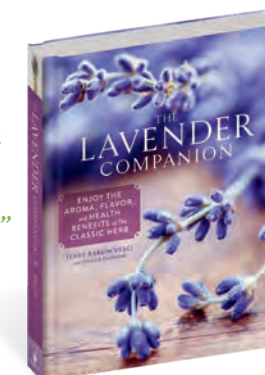

"Gives lavender lovers a great starting point to selecting, growing, and using this popular herb."

—*The American Gardener*

The Lavender Companion

TERRY BARLIN VESCI

This lavishly photographed celebration of the beloved herb, written by an acclaimed lavender farmer and cooking instructor, is brimming over with inspiration and ideas for bringing the fragrance and flavor of lavender into daily life. The book profiles the most popular lavender varieties and their recommended uses, along with the history, lore, and traditional medicinal uses. More than 40 recipes showcase lavender in delicious dishes from the kitchen as well homemade craft and body products. Tips for success with lavender in the garden complete this perfect gift for every lavender lover.

Hardcover; 176 pages; 7 x 9
Full-color
\$26.00 US
ISBN 978-1-63586-684-1



"This is the one go-to resource for all things kombucha."

—Andrew Zimmern, James Beard Award-winning author and host of Travel Channel's *Bizarre Foods*



The Big Book of Kombucha

HANNAH CRUM & ALEX LAGORY

Kombucha is taking the healthy beverage market by storm. Unlike any other book on the topic, this one-stop reference features dozens of step-by-step photographs, recipes for more than 200 flavor combinations, and an extensive troubleshooting guide for successful home brewing.

■ Silver Nautilus Award
■ **174,000 COPIES IN PRINT**

Paper; 400 pages; 8 x 9
Full-color
\$26.99 US
ISBN 978-1-61212-433-9

Hardcover; **\$36.95 US**
ISBN 978-1-61212-434-6



Drink the Harvest

NAN K. CHASE & DENEICE C. GUEST

Preserving enthusiasts, gardeners, and anyone seeking alternatives to sugary store-bought drinks can turn to these techniques and recipes for making fresh fruits, vegetables, and herbs into delicious and nutritious homemade juices, syrups, and fermented beverages to enjoy year-round.

Paper; 232 pages; 7 x 9
Full-color
\$21.99 US
ISBN 978-1-61212-159-8

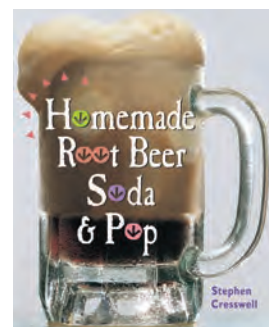

Homemade Root Beer, Soda & Pop

STEPHEN CRESSWELL

Tastier, healthier, and cheaper than store-bought sodas, this collection of 60 recipes includes traditional favorites like Root Beer, Birch Beer, and Ginger Beer, and new flavor combinations like Coffee Whizzer, Mint-Lime Cooler, and Wintertime Cinnamon Shrub.

■ **58,000 COPIES IN PRINT**

Paper; 128 pages; 7½ x 9¼
Two-color
\$14.95 US
ISBN 978-1-58017-052-9



Homemade Liqueurs and Infused Spirits

ANDREW SCHLOSS

These 157 liqueur and spirit recipes include 21 name-brand clones, such as Chambord and Baileys. With another 80 recipes for cocktails that use liqueurs, this is the one-stop shop for creating fantastically flavored drinks.

Paper; 272 pages; 7 x 9¼
Full-color
\$19.95 US
ISBN 978-1-61212-098-0

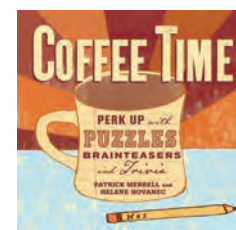

Coffee Time

PATRICK MERRELL & HELENE HOVANEC

Here is the perfect gift for the latte-obsessed and the espresso-addicted, with a challenging collection of crossword puzzles, word searches, graphic mazes, and sudoku, plus quirky trivia, fun factoids, and caffeinated quotations.

■ **53,000 COPIES IN PRINT**

Paper; 320 pages; 4¼ x 4¼
Two-color
\$9.99 US
ISBN 978-1-58017-683-5



Cider

ANNIE PROULX & LEW NICHOLS

The ultimate handbook for the cidemaker, this guide covers everything from choosing and planting the best apple varieties to building an apple press and crafting sweet and hard ciders, including blended and sparkling varieties.

Paper; 224 pages; 6 x 9
Illustrations throughout
\$14.95 US
ISBN 978-1-58017-520-3



Tasting Cider

ERIN JAMES & CIDERCRAFT® MAGAZINE

This inspiring guide to hard cider's rich history and its modern makers includes flavor profiles and tasting guidelines for 100 selections of cider. Cider pairings are featured with 30 food recipes, and an additional 30 cocktail recipes provide creative possibilities.

Paper; 288 pages; 7 x 9¼
Full-color
\$19.95 US
ISBN 978-1-61212-837-5



"Offers details, charming drawings, hand-drawn titles, bits of history regarding the popular brew, tributes, and entertaining anecdotes."

—*Edible East Bay*

Fire Cider!

ROSEMARY GLADSTAR

For more than 30 years, herbalist Rosemary Gladstar has been touting the health benefits of fire cider—a spicy blend of apple vinegar, onion, ginger, horseradish, garlic, and other immune-boosting herbs. In this lively celebration of a beloved and versatile folk remedy, more than 70 herbal enthusiasts contribute 101 recipes ranging from Black Currant Fire Cider to Triple Goddess Vinegar, Fire Cider Dark Moonshine, and Bloody Mary Fire Cider.

Paper; 204 pages; 7 x 9
Full-color
\$17.99 US
ISBN 978-1-63586-180-8

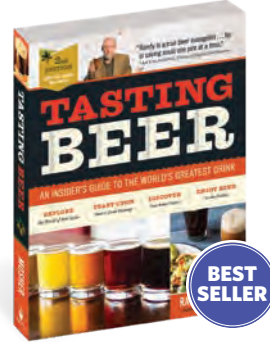

“Randy Mosher is a true beer evangelist ... he is saving souls one pint at a time.”

—Sam Calagione, owner of Dogfish Head Craft Brewery

Tasting Beer, 2nd Edition

RANDY MOSHER

This completely updated go-to beer resource features the most current information on beer styles, flavor profiles, sensory evaluation guidelines, craft beer trends, food and beer pairings, and draft beer systems, reflecting the Beer Judge Certification Program’s latest style guidelines. Spirited drinkers will also enjoy the new section on beer cocktails.

Paper; 376 pages; 7 x 9 1/4
Full-color
\$19.95 US
ISBN 978-1-61212-777-4
Hardcover;
\$29.95 US
ISBN 978-1-61212-781-1



“Finally, a cookbook made for beer geeks!”

—Savour.com

The American Craft Beer Cookbook

JOHN HOLL

The profiles and recipes in this engaging cookbook represent the best from brewpubs, breweries, and brewers around the world. From Free-Range Super Pancakes to Barley-Crusted Tuna Sandwiches, these 150 recipes fan the craft beer fire with flavors that enhance the taste of a good cold one.

■ **55,000 COPIES IN PRINT**

Paper; 352 pages; 8 x 9
Full-color
\$22.95 US
ISBN 978-1-61212-090-4

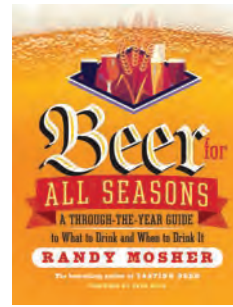

Beer for All Seasons

RANDY MOSHER

This book highlights the best brew fests and seasonal beer releases and describes the beers that will perfectly complement warm spring afternoons, barbecues with friends, traditional Thanksgiving dinners, and icy winter nights.

Paper; 200 pages; 6 1/2 x 8 1/2
Full-color
\$14.95 US
ISBN 978-1-61212-347-9

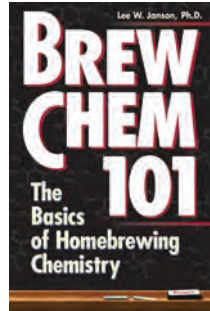

Brew Chem 101

LEE W. JANSON, PhD

Now homebrewers can make better beer with this thoroughly readable primer on the basic science behind every step of the brewing process, from the life of yeast to avoiding off-flavors and tasting finished brews.

■ **36,000 COPIES IN PRINT**

Paper; 128 pages; 6 x 9
Full-color
\$14.95 US
ISBN 978-0-88266-940-3



Vintage Beer

PATRICK DAWSON

Identify a cellar-worthy beer by learning what to look for when tasting aged beers and explore the fascinating science behind the aging process. This book also includes a guide to selecting already-aged beers and tips on setting up a beer cellar.

Paper; 160 pages; 6 x 8
Full-color
\$14.95 US
ISBN 978-1-61212-156-7



The Homebrewer's Garden, 2nd Edition

JOE FISHER & DENNIS FISHER

For homebrewers who take great pride in every aspect of their brew, including growing their own ingredients, this is the go-to reference for gardening guidance. This second and expanded edition includes 29 specialty homebrew recipes and grower/brewer profiles.

Paper; 216 pages; 6 x 9
One-color with 8-page full-color insert
\$16.95 US
ISBN 978-1-61212-686-9

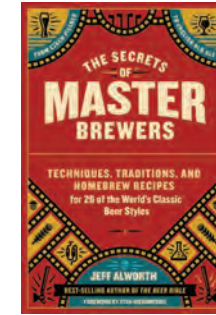

The Secrets of Master Brewers

JEFF ALWORTH

From how the Irish make stout to the secrets of traditional Czech pilsner, readers learn about the techniques, equipment, and geographies that shape 26 of the world’s classic beer styles. Major brewers share original recipes to guide experienced homebrewers in making their own versions of each style.

Paper; 304 pages; 6 x 9
Two-color
\$24.95 US
ISBN 978-1-61212-654-8



Making Wild Wines & Meads

PATTIE VARGAS & RICH GULLING

Herbs, fruits, and flowers take center stage in these 125 unique recipes for exquisite elixirs. Simple step-by-step instructions guide adventurous brewers through the process of making extraordinary wines from ingredients found in the backyard or local market.

■ **55,000 COPIES IN PRINT**

Paper; 176 pages; 6 x 9
\$16.95 US
ISBN 978-1-58017-182-3



“You won’t find a better or more complete guide to understanding and learning how to taste whiskey.”

—Drink Spirits

Tasting Whiskey

LEW BRYSON

Whiskey lovers will devour this fresh and comprehensive guide to everything there is to know about the world’s whiskeys. Exploring the traditions behind bourbon, Scotch, Irish, and even Japanese whiskey, readers discover how unique flavors are created through variations of ingredients and different distilling techniques.

With advice on how to collect, age, and serve whiskey, as well as recipes for cocktails and suggestions for proven food pairings, this is the guide no whiskey drinker will want to be without!

■ IACP Award Finalist
■ **66,000 COPIES IN PRINT**

Paper; 256 pages; 7 x 9 1/4
Full-color
\$22.99 US
ISBN 978-1-61212-301-1

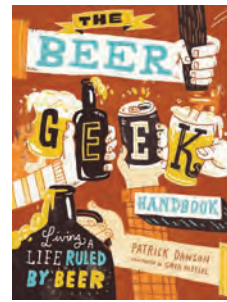

The Beer Geek Handbook

PATRICK DAWSON

To a beer geek, beer isn’t simply a drink, but a lifestyle. With guidance for pulling off a beer tasting, tips on gracefully correcting an uninformed bartender, the Ten Beer Geek Commandments, and much more, this handbook offers humor and savvy about what’s cool and what’s not in beer, breweries, personalities, and behavior.

Paper; 192 pages; 6 x 8
Full-color
\$14.95 US
ISBN 978-1-61212-531-2

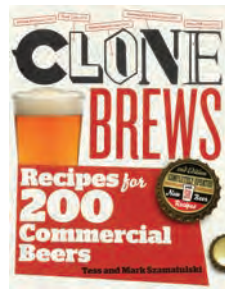

CloneBrews, 2nd Edition

TESS & MARK SZAMATULSKI

Revised, updated, and expanded, this second edition guide to making commercial-style beers at home contains 50 brand-new recipes, fully updated mashing guidelines, and a food-pairing feature that recommends the best foods for every beer.

Paper; 440 pages; 7 x 9
Two-color
\$19.95 US
ISBN 978-1-60342-539-1



Dave Miller's Homebrewing Guide

DAVE MILLER

Clear enough for the novice but thorough enough to earn a home in the library of brewmasters, this comprehensive guide takes homebrewers step by step through the best techniques for brewing great-tasting beer.

■ **96,000 COPIES IN PRINT**

Paper; 368 pages; 6 x 9
Illustrations throughout
\$16.95 US
ISBN 978-0-88266-905-2



The Homebuilt Winery

STEVE HUGHES

Home winemakers get all the know-how they need to set up their own winery and build the basic equipment for just a fraction of the cost of store-bought. This helpful guide has building plans and step-by-step instructions for more than 30 winemaking essentials—including a crusher, a destemmer, presses, pumps, and a bottle filler.

Paper; 208 pages; 8 1/2 x 10 1/2
Photographs and illustrations throughout
\$19.95 US
ISBN 978-1-60342-990-0



The Home Winemaker's Companion

GENE SPAZIANI & ED HALLORAN

Here are 115 delectable recipes to guide home winemakers through everything from making their first wine from a kit to mastering advanced techniques for making wine from grapes.

■ **58,000 COPIES IN PRINT**

Paper; 272 pages; 8 x 8
Two-color
\$19.95 US
ISBN 978-1-58017-209-7



From Vines to Wines, 5th Edition

JEFF COX

From breaking ground to savoring the finished product, this classic guide covers every aspect of growing flawless grapes and making extraordinary wine. Illustrated instructions explain how to choose and prepare a vineyard site; build effective trellising; select, prune, and harvest grapes based on climate; press, ferment, age, and bottle wine; and more!

Paper; 264 pages; 6 x 9
Illustrations throughout
\$19.99 US
ISBN 978-1-61212-438-4

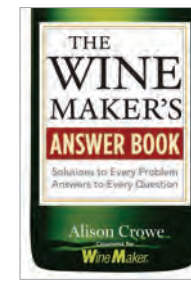

The Winemaker's Answer Book

ALISON CROWE

In a friendly Q&A format, this reassuring reference explains the entire winemaking process—from choosing grapes to sanitizing bottles—and offers proven solutions for fixing problems.

■ **39,000 COPIES IN PRINT**

Flexibind; 384 pages; 4 1/4 x 6 1/2
Two-color
\$14.95 US
ISBN 978-1-58017-656-9



Wild Winemaking

RICHARD W. BENDER

Accessible for first-timers and intriguing for seasoned winemakers, this intoxicating guide focuses on small-batch wines that require minimal equipment and use an unexpected range of readily available fruits, vegetables, flowers, and herbs.

Paper; 272 pages; 7 x 9
Full-color
\$19.95 US
ISBN 978-1-61212-789-7

ADVENTURE, EXPLORE, DISCOVER!

Colorful take-along field guides for kids encourage the littlest explorers to look, listen, touch, play, and discover the wonders of the natural world. Each book includes scavenger hunts, kid-friendly nature activities, a magnifying glass and stickers!



**Backpack Explorer:
On the Nature Trail**

\$12.95 US
ISBN 978-1-63586-197-6



**Backpack Explorer:
Beach Walk**

\$12.95 US
ISBN 978-1-61212-902-0



**Backpack Explorer:
Bird Watch**

\$12.99 US
ISBN 978-1-63586-251-5



**Backpack Explorer:
Bug Hunt**

\$12.99 US
ISBN 978-1-63586-313-0



**Backpack Explorer:
Rock Hunt**

\$12.99 US
ISBN 978-1-63586-553-0



Best-selling kids nature guides include:

- Full-color
- 48 pages; 7 7/8 x 9 1/4
- Magnifying Glass
- Hardcover Format
- 3 Sticker Sheets
- Pull-out Map/Journal

For ages 4+



**Backpack Explorer:
Discovering Trees**

\$12.95 US
ISBN 978-1-63586-346-8



**Backpack Explorer:
Plants And Flowers**

\$12.99 US
ISBN 978-1-63586-675-9



**Backpack Explorer
Stickers: Nature
Adventure**

\$14.99 US
ISBN 978-1-63586-862-3



**Backpack Explorer
5-Book Set with Nature
Collection Box**

5-book boxed set with sturdy nature collection box; 240 pages; 7.89 x 9.65 Full-color \$64.99 US ISBN 978-1-63586-666-7



LIFELIKE TATTOOS THAT LAST FOR DAYS

Realistic Art with Fascinating Facts.



Wild, Wonderful Tattoo Woodland Animals: 60 Temporary Tattoos That Teach

Illustrations by Nora Potwora
\$8.99 US
ISBN: 978-1-63586-800-5



Cool, Cosmic Tattoo Stars and Planets: 50 Temporary Tattoos That Teach

Illustrations by Meg Thacher; illustrations by Angela Rizza
\$8.99 US
ISBN: 978-1-63586-799-2



Cute, Cuddly Tattoo Cats & Kittens: 60 Temporary Tattoos That Teach

Illustrations by Nora Potwora
\$8.99 US
ISBN: 978-1-63586-797-8



Furry, Friendly Tattoo Dogs & Puppies: 60 Temporary Tattoos That Teach

Illustrations by Nora Potwora
\$8.99 US
ISBN: 978-1-63586-798-5



Slithering, Scaly Tattoo Snakes & Other Reptiles: 60 Temporary Tattoos That Teach

Illustrations by Artemis Roehrig; illustrations by K.L. Murphy
\$8.99 US
ISBN: 978-1-63586-667-4



Soaring, Singing Tattoo Birds: 60 Temporary Tattoos That Teach

Illustrations by Artemis Roehrig; illustrations by K.L. Murphy
\$8.99 US
ISBN: 978-1-63586-668-1



Super, Strong Tattoo Sharks: 50 Temporary Tattoos That Teach

Illustrations by Artemis Roehrig; illustrations by Aaron John Gregory
\$8.99 US
ISBN: 978-1-63586-318-5



Roaring, Rumbling Tattoo Dinosaurs: 50 Temporary Tattoos That Teach

Illustrations by Artemis Roehrig; illustrations by Aaron John Gregory
\$8.99 US
ISBN: 978-1-63586-319-2



Fluttery, Friendly Tattoo Butterflies and Other Insects: 81 Temporary Tattoos That Teach

Illustrations by Artemis Roehrig; illustrations by Jillian Ditner
\$8.99 US
ISBN: 978-1-63586-202-7



Creepy, Crawly Tattoo Bugs: 60 Temporary Tattoos That Teach

Illustrations by Artemis Roehrig; illustrations by Jillian Ditner
\$8.99 US
ISBN: 978-1-63586-196-9

Create Your Own Mix & Match Book Display!

ISBN: 978-0-7611-7972-6



Select your customized assortment of 32 titles and add FREE empty counter display to your order.

Display measures approximately 18" wide x 10.5" high x 2" deep

NEW BUSY LITTLE HANDS SERIES



"With this introduction, youngsters will develop good science habits while they are learning."
—Kirkus

Busy Little Hands: Science Play!

SUSAN EDWARDS RICHMOND

In this fourth book in the Busy Little Hands series, preschoolers wonder and explore with 20 hands-on experiments using everyday household objects and making daily activities such as snack time and play time into learning opportunities. Each play activity demonstrates a simple principle of physics, earth science, chemistry, or biology. Featuring easy-to-follow photos specially designed for pre-readers, this book is packed with learning fun.

■ For ages 3-5

Hardcover; 48 pages; 8 x 9
Full-color
\$12.99 US
ISBN 978-1-63586-465-6



Busy Little Hands: Math Play!

LINDA DAUKSAS & JEANNE WHITE

This activity book helps preschoolers cultivate a love of numbers, with hands-on learning projects and fun ways to integrate math into everyday life. Each activity is designed for little mathematicians to play with numbers as they count, compare, measure, and make patterns using toys, snacks, and other items that are part of everyday life.

Hardcover; 48 pages; 8 x 9
Full-color
\$12.95 US
ISBN 978-1-63586-375-8



Busy Little Hands: Food Play!

AMY PALANJIAN

Preschoolers can learn how to prepare their own food and develop healthy eating habits with activities that foster fun in the kitchen. Each photo-driven recipe is easy for little hands to manage and encourages kids to try new flavors and textures and discover their personal tastes.

Hardcover; 48 pages; 8 x 9
Full-color
\$14.99 US
ISBN 978-1-63586-267-6



Busy Little Hands: Art Play!

MEREDITH MAGEE DONNELLY

Using paint, colored paper, clay, and other basic art supplies, preschoolers learn to tap into their natural artistic abilities with fun-filled, creative projects. From bubble prints to a Super Kid cape, each activity is explained through easy-to-follow, colorful photos and encourages creative self-expression.

Hardcover; 48 pages; 8 x 9
Full-color
\$14.99 US
ISBN 978-1-63586-269-0

BEST-SELLING SERIES FROM DEANNA F. COOK



Kids Cook Dinner

This selection of 25 easy, budget-friendly dinner recipes from the best-selling Cooking Class series teaches kids how to make tasty, healthy meals with easy-to-follow step-by-step photos. With instructions on basic cooking skills, like chopping vegetables and stir-frying, grocery shopping, and kitchen safety, this book offers aspiring chefs ages 8 to 12 everything they need to know.

■ For ages 8-12
Paper; 64 pages; 8½ x 9½
Full-color
\$9.95 US
ISBN 978-1-63586-463-2

Includes cutting board

Cooking & Baking Class Box Set

This slipcase set features the best-selling combo of *Cooking Class* and the IACP Award-winning *Baking Class*, along with a bonus food-grade plastic cutting board.

■ For ages 6-12
Two paperbacks with concealed wire-o and a food-grade cutting board in a slipcase, shrink-wrapped; **\$40.00 US**
ISBN 978-1-63586-079-5

Cooking Class Global Feast!

Young chefs embark on a tasty tour of global cultures and cuisines with recipes from around the world. Infographics encourage taste-testing of foods from across the globe, and a pop-out food passport, language flashcards, and flag stickers provide extra fun.

■ For ages 6-12
Paper with concealed wire-o and bound-in cards and stickers; 144 pages; 9 x 9½
Full-color
\$18.95 US
ISBN 978-1-63586-126-6
Library edition; **\$28.99 US**
ISBN 978-1-63586-230-0

Baking Class

This delightful baking guide for kids features 50 easy-to-follow recipes for all their favorites. Lively step-by-step photos teach bakers-in-training how to knead dough, decorate cookies, and produce a perfect pie, along with essential skills like following directions and accurately measuring ingredients.

■ For ages 8-12
■ National Parenting Product Award
■ Gold Mom's Choice Award
■ IACP Award Finalist
■ **180,000 COPIES IN PRINT**

Paper with concealed wire-o, 4 sticker sheets, and 5 perforated cardstock sheets; 144 pages; 9 x 9½
Full-color
\$18.95 US
ISBN 978-1-61212-855-9

Cooking Class

Kids learn basic cooking techniques and simple recipes for favorite foods like French toast, applesauce, and buffalo chicken fingers with the help of stickers, recipe cards, and fun conversation starters.

■ For ages 6-12
■ National Parenting Product Award
■ Gold Mom's Choice Award
■ Silver Parents' Choice Award
■ IACP Award Finalist

Hardcover; 188 pages; 9 x 9½; includes 3 sticker sheets and 3 cardstock sheets
Full-color
\$19.99 US
ISBN 978-1-63586-779-4

NEW I WANT TO BE A ACTIVITY SERIES

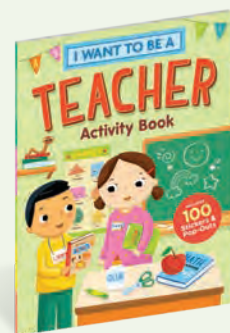

I Want to Be a Teacher Activity Book

With 100 stickers and pop-out props, preschoolers have everything they need to play teacher. Kids use colorful report cards, attendance sheets, reward stickers, and more to conduct classes for their stuffed animals and friends, laying the foundation for learning within the structure and routines of the classroom environment.

■ For ages 4-7
Paper with 3 sticker sheets and 3 cardstock sheets; 24 pages; 8½ x 10½
Full-color
\$7.95 US
ISBN 978-1-63586-347-5



I Want to Be a Farmer Activity Book

This interactive package will fuel hours of imaginative play, with illustrated stickers and sturdy pull-out components that offer everything a little farmer needs to plant, harvest, and sell fresh-from-the-farm crops at a pretend market.

■ For ages 4-7
Paper with 3 sticker sheets and 3 cardstock sheets; 20 pages; 8½ x 10½
Full-color
\$7.95 US
ISBN 978-1-63586-217-1



I Want to Be a Vet Activity Book

Aspiring vets will find everything they need to set up a pretend vet clinic and provide top-notch care for their stuffed animal friends, with stickers and sturdy paper pop-outs that promise hours of creative role-play.

■ For ages 4-7
Paper with 3 sticker sheets and 2 cardstock sheets; 20 pages; 8½ x 10½
Full-color
\$8.99 US
ISBN 978-1-63586-216-4



I Did It Myself!

SANIYAH KHALILALLAH

Montessori teacher Saniyiah Kahalilallah makes it fun and easy for kids to practice self-care, with step-by-step photos teaching how to wash hands, brush hair, get dressed, and features an interactive skills chart.

■ For ages 3-5
Hardcover; 32 pages; 7 x 10½
Full-color
\$16.99 US
ISBN 978-1-63586-551-6



I Help at Home!

SANIYAH KHALILALLAH

Montessori teacher Saniyiah Kahalilallah teaches practical life skills in a step-by-step photographic format specially designed for 3- to 5-year-olds. The interactive skills chart with sliding windows makes it fun for kids to record their daily accomplishments.

■ For ages 3-5
Hardcover; 32 pages; 7 x 10½
Full-color
\$16.99 US
ISBN 978-1-63586-523-3



Food Faces

DEANNA F. COOK

Eye-catching faces made from nutritious foods provide a playful introduction to animals, shapes, colors, and healthy eating. From the muffin-faced monkey to the kiwi-eyed owl, each creation features cleverly disguised fruits, vegetables, cheese, and other toddler favorites.

Board book; 22 pages; 6 x 6
Full-color
\$6.95 US
ISBN 978-1-63586-279-9



Baby's First Kind Words

HSPINING PAN

This sweet board book is a joyful way to teach the language of kindness at the earliest stages of learning. Charming illustrations bring the nicest words, such as "gentle," "share," "listen," and "friends," to life for the littlest children.

Board book; 20 pages; 6 x 6
Full-color
\$6.95 US
ISBN 978-1-63586-250-8



Give Thanks

NAOMI SHULMAN

Best-selling author-illustrator team of *Be Kind*, Naomi Shulman and Hsinping Pan, return with this collection of 50 simple gratitude prompts featuring hands-on activities, from starting a gratitude journal and taking a thankfulness walk to playing gratitude games at the dinner table, that go beyond simply saying "thanks."

Hardcover; 64 pages; 6 x 9
Full-color
\$12.95 US
ISBN 978-1-63586-399-4

"This beautifully illustrated book gives fresh and meaningful ways that each child — and adult — can make our world a happier place and prove that KINDNESS MATTERS!"

— Jill McManigal, cofounder executive director, Kids for Peace and The Great Kindness Challenge



Be Kind

NAOMI SHULMAN

Be Kind offers children aged 5 and up simple, actionable things they can do in their daily lives that help them cultivate kindness. With joyful illustrations and kid-friendly writing, this idea book serves as a delightful, easy-to-read collection of 125 concrete activities kids and their families can pick and choose from and act out in their daily lives, no special occasion required. On every page, *Be Kind* empowers kids to make the world a better, kinder place, one action at a time.

■ For ages 5 and up
■ Gold Mom's Choice Award
Hardcover; 80 pages; 6 x 9
Full-color
\$12.95 US
ISBN 978-1-63586-154-9

NEW CIRCLE ROUND SERIES



"The storytelling power in this book will leave you delighted and inspired and entertained!"

— Guy Raz, Wow in the World and How I Built This

The Great Ball Game

REBECCA SHEIR

A classic folktale originating from the Cherokee, Creek, Ojibway and Menominee people of North America, is adapted for a contemporary audience. A dispute between the animals and the birds over who is best leads to a ball game challenge where all the participants learn the value of diversity and celebrating those who seem "different."

■ For ages 5 and up
Hardcover; 44 pages; 8½ x 8½
 Full-color
\$14.99 US
 ISBN 978-1-63586-343-7

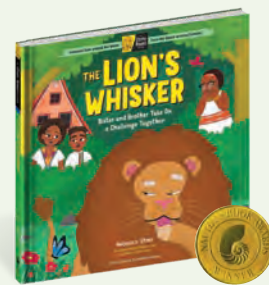

The Lion's Whisker

REBECCA SHEIR

Courage, patience, and sibling love prevail in this folktale with its roots in the Ethiopian tradition. *The Lion's Whisker* tells the story of siblings that learn valuable lessons about the strength gained by working together, being brave, and showing understanding for others.

■ For ages 5 and up
 Nautilus Book Awards, Gold Winner
 ■ For ages 5 and up
Hardcover; 44 pages; 8½ x 8½
 Full-color
\$14.99 US
 ISBN 978-1-63586-520-2



A Taste of Honey

REBECCA SHEIR

A story with roots in India, this folktale invites kids to explore the value of learning to use your smarts and develop confident problem-solving abilities. The colorful illustrations of Indian illustrator Chaaya Prabhat bring the story to life.

■ For ages 5 and up
Hardcover; 44 pages; 8½ x 8½
 Full-color
\$14.95 US
 ISBN 978-1-63586-492-2



The Tale of the Unwelcome Guest

REBECCA SHEIR

Circle Round podcast host Rebecca Sheir's original adaptation of this Middle Eastern folktale invites kids to explore the value of acceptance and the danger of judging others by their appearance. Specially designed to be read aloud and shared, the story is accompanied by creative storytelling activities.

■ For ages 5 and up
Hardcover; 44 pages; 8½ x 8½
 Full-color
\$14.95 US
 ISBN 978-1-63586-314-7



Guess My Animal!

KATHLEEN YALE

Learn about 40 endangered animals and their wild and wacky behaviors with this interactive card game featuring a pull-out poster showing every animal, and a colorful booklet with more fascinating facts about their habitat, diet, and behavior.

■ For ages 6 and up
Card deck with 44 page booklet and 15 x 21 poster; 44 pages; 5½ x 7½ x 1¼
 Full-color
\$18.99 US
 ISBN 978-1-63586-622-3

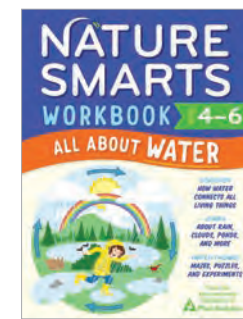

Nature Smarts Workbook: All about Water (Ages 4-6)

THE ENVIRONMENTAL EDUCATORS OF MASS AUDUBON

In this special water-themed workbook, kids ages 4 to 6 learn all about how water connects every living thing. Each page builds curiosity and early science skills, nature observation, and investigation with on-the-page puzzles and outdoor learning activities.

■ For ages 4-6
Paper; 96 pages; 8¼ x 11¼
 Full-color
\$12.99 US
 ISBN 978-1-63586-780-0

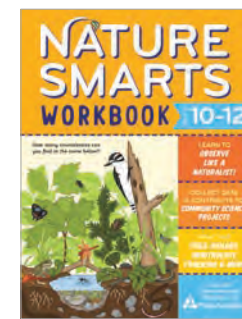

Nature Smarts Workbook, Ages 10-12

THE ENVIRONMENTAL EDUCATORS OF MASS AUDUBON

This activity book for kids ages 10-12 builds skills in field biology and nature observation with interactive learning activities. Adapted from Mass Audubon's acclaimed nature camps, this workbook includes in-depth lessons on plants, invertebrates, birds, habitats, herptiles, and mammals.

■ For ages 10-12
Paper; 112 pages; 8¼ x 11¼
 Full-color
\$9.99 US
 ISBN 978-1-63586-398-7

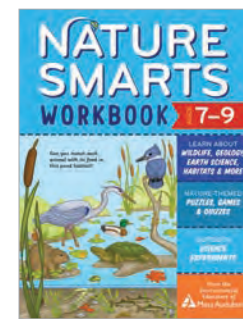

Nature Smarts Workbook, Ages 7-9

THE ENVIRONMENTAL EDUCATORS OF MASS AUDUBON

For kids ages 7-9, this collection includes matching games, puzzles, and hands-on outdoor activities to introduce earth science, weather, basic botany, and wildlife identification, while fostering skills in pattern identification and classification.

■ For ages 7-9
Paper; 96 pages; 8¼ x 11¼
 Full-color
\$9.95 US
 ISBN 978-1-63586-397-0

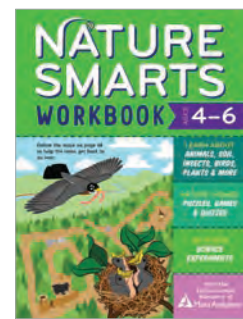

Nature Smarts Workbook, Ages 4-6

THE ENVIRONMENTAL EDUCATORS OF MASS AUDUBON

With an emphasis on teaching basic observational skills and introducing kids ages 4-6 to the investigation method, the worksheets follow the acclaimed nature curriculum developed by the environmental educators at Mass Audubon.

■ For ages 4-6
Paper; 96 pages; 8¼ x 11¼
 Full-color
\$9.95 US
 ISBN 978-1-63586-396-3



Love Your Amazing Self

OFOSU JONES-QUARTEY

This original, brightly illustrated collection of self-affirming lyrical meditations for kids ages 7 and up from Ofosu Jones-Quarthey, a meditation teacher and recording artist, celebrates joy, resilience, empowerment, and self-compassion.

■ For ages 7 and up
Hardcover; 72 pages; 9¼ x 9¼
 Full-color
\$17.99 US
 ISBN 978-1-63586-547-9



Mindful Moves

NICOLE CARDOZA

This guide provides children aged 5 and up with fun movement and mindfulness activities, all joyfully illustrated, to help them quiet their worries, relax their bodies, and discover the benefits of being present in the moment.

■ For ages 5-7
Hardcover; 64 pages; 8 x 9
 Full-color
\$14.95 US
 ISBN 978-1-63586-271-3



How to Sleep Tight Through the Night

TZIVIA GOVER & LESLÉA NEWMAN

This lushly illustrated nighttime companion is filled with practical ways to help children ages 5 to 9 with reassuring nighttime routines, creative visualizations, and kid-friendly techniques for addressing bedtime reluctance, managing fears and anxiety, and inviting pleasant dreaming.

■ For ages 5-9
Hardcover; 64 pages; 8 x 9
 Full-color
\$14.95 US
 ISBN 978-1-63586-424-3

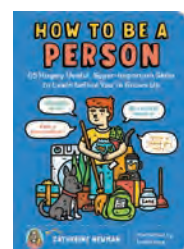

How to Be a Person

CATHERINE NEWMAN

Here is the ultimate kids' guidebook to becoming a beyond-helpful human—and someone who likes themselves better, too! Friendly, non-judgmental tips and tricks and irresistible graphic novel-style illustrations show young readers how to use a debit card, care for pets, build a fire, and more.

■ For ages 10 and up
102,000 COPIES IN PRINT
Paper; 160 pages; 6½ x 9
 Full-color
\$16.99 US
 ISBN 978-1-63586-182-2

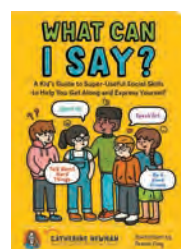

What Can I Say?

CATHERINE NEWMAN

Catherine Newman teaches kids essential communication and social skills including: how to get along with others, stand up for themselves, talk about hard things, be an ally, and a good friend. All of the 50+ scripts and tips are presented in an accessible, non-judgmental voice with graphic-novel style illustrations.

■ For ages 10 and up
Paper; 160 pages; 6½ x 9
 Full-color
\$16.95 US
 ISBN 978-1-63586-434-2



Howl Like a Wolf!

KATHLEEN YALE

This activity book invites kids ages six and up to learn all about the animal kingdom. Thirteen different mammals, reptiles, and insects introduce themselves, then invite kids to mimic their movements, sounds, and behaviors. Previously published in hardcover, the paperback edition features 11 pop-out, child-size paper masks ready for use.

■ For ages 10 and up
Paper with 16 perforated cardstock sheets; 72 pages; 8 x 10
 Full-color
\$9.95 US
 ISBN 978-1-63586-461-8



Let's Learn to Fish!

DAN ARMITAGE

In this skills-based book, kids ages 6 and up learn essential techniques on how to fish. Step-by-step photography shows the best beginner bait and tackle, key skills such as rigging, casting, and reeling in fish, and tips on where to fish.

■ For ages 6 and up
Paper; 128 pages; 7 x 9
 Full-color
\$16.99 US
 ISBN 978-1-63586-582-0

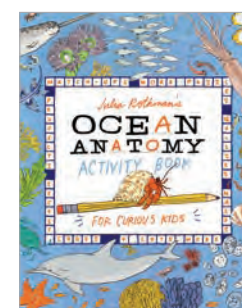

Julia Rothman's Ocean Anatomy Activity Book

JULIA ROTHMAN

The bestselling author and illustrator of *Ocean Anatomy* presents a companion activity book with creativity and learning activities, including matching challenges, mazes, ID and drawing exercises, nature journaling, and observational challenges.

■ For ages 8-12
Paper; 64 pages; 8 x 10
 Full-color
\$12.99 US
 ISBN 978-1-63586-778-7

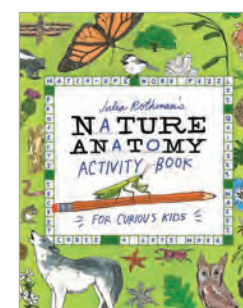

Julia Rothman's Nature Anatomy Activity Book

JULIA ROTHMAN

Julia Rothman's invites her many young fans to try their hand at identifying, drawing, and learning the parts and pieces of the natural world. Rothman's creative quizzes, puzzles, and nature activities will pique the curiosity for kids of all ages.

■ For ages 8-12
Paper; 64 pages; 8 x 10
 Full-color
\$12.99 US
 ISBN 978-1-63586-768-8



Julia Rothman's Farm Anatomy Activity Book

JULIA ROTHMAN

Loaded with Rothman's original illustrations, this interactive format a lively collection of on-the-page quizzes, puzzles, and activities will intrigue and entertain you, whether you live on a farm or not.

■ For ages 8-12
Paper; 64 pages; 8 x 10
 Full-color
\$12.99 US
 ISBN 978-1-63586-872-2

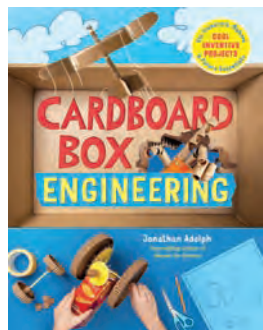

Cardboard Box Engineering

JONATHAN ADOLPH

Cardboard is a sturdy, easy-to-source material for young makers, tinkerers, and creative thinkers to work with. In this collection of cool cardboard projects, kids learn engineering, physics, and animatronics as they construct a robotic hand, a windpowered tractor, a marble roller coaster, and more.

Paper; 176 pages; 8½ x 10½
Full-color
\$16.99 US
ISBN 978-1-63586-214-0

Hardcover;
\$26.99 US
ISBN 978-1-63586-360-4



BEST SELLER

Mason Jar Science

JONATHAN ADOLPH

Heatproof, transparent, durable, and plentiful in many kitchens, the mason jar is a science lab waiting to be discovered. This book offers dozens of small-scale ways to illustrate the big-picture principles of chemistry, botany, biology, physics, and more in 40 dynamic experiments that budding scientists can conduct with a jar and a few ordinary household items.

Paper; 176 pages; 8 x 10
Full-color
\$16.99 US
ISBN 978-1-63586-214-0

Hardcover; 136 pages; 7 x 10
Full-color
\$18.99 US
ISBN 978-1-63586-360-4

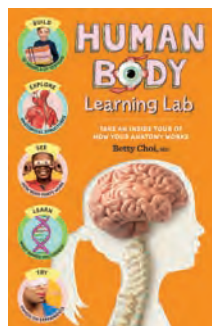

Human Body Learning Lab

BETTY CHOI, MD

Pediatrician Dr. Betty Choi takes kids ages 8 and up on an engaging exploration of the inner workings of all the major systems of the human body, with hands-on learning lab experiments, colorful diagrams and infographics, model building, and challenging games.

Paper; 144 pages; 7 x 10½
Full-color
\$18.99 US
ISBN 978-1-63586-479-3

Hardcover; 144 pages; 7 x 10½
Full-color
\$26.99 US
ISBN 978-1-63586-623-0



Wood Shop

MARGARET LARSON

The perfect gift for tinkerers and young makers, this kid-friendly woodworking book teaches essential tool-handling skills, and offers step-by-step photographs and clear instructions for 17 projects to furnish the wood shop, decorate a bedroom, and fuel the imagination.

Paper; 216 pages; 9 x 9½
Full-color
\$19.99 US
ISBN 978-1-61212-942-6



Say Cheese!

RICKI CARROLL & SARAH CARROLL

Making cheese at home is easy, and this fun guide shows families how. Step-by-step photos take kids through the cheesemaking process and teach them how to make 10 of their favorites, including mozzarella, feta, ricotta, and cream cheese.

Paper with concealed wire-o and sticker sheets; 136 pages; 9 x 9½
Full-color
\$18.95 US
ISBN 978-1-61212-823-8

BEST-SELLING SERIES SEWING SCHOOL®



Sewing School®

AMIE PETRONIS PLUMLEY & ANDRIA LISLE

With 21 inspired projects, kids can learn how to sew—no sewing machine needed. Step-by-step photography and full-size cut-out patterns guide children through making pillows, dolls, blankets, totes, and more.

Paper with concealed wire-o and patterns; 144 pages; 9 x 9½
Full-color
\$18.95 US
ISBN 978-1-60342-578-0



Sewing School® 2

AMIE PETRONIS PLUMLEY & ANDRIA LISLE

Kid-friendly step-by-step text and photographs teach children the skills and techniques they need to master machine sewing. Reusable full-size pattern pieces are included in a bound-in envelope.

Paper with concealed wire-o and patterns; 160 pages; 9 x 9½
Full-color
\$19.95 US
ISBN 978-1-61212-049-2



Sewing School® Quilts

AMIE PETRONIS PLUMLEY & ANDRIA LISLE

The creativity and timeless appeal of quilting reaches a new generation. Young sewists learn hand- and machine-sewing techniques and create projects both decorative and practical, including a patchwork pet bed, a crazy-quilt journal cover, and a recycled T-shirt quilt.

Paper with concealed wire-o and patterns; 160 pages; 9 x 9½
Full-color
\$18.95 US
ISBN 978-1-61212-859-7



Sewing School® Fashion Design

AMIE PETRONIS PLUMLEY & ANDRIA LISLE

This comprehensive kids' course comes with clothing patterns for sizes XS-XL. Step-by-step photos and actual kid-created examples teach young sewers the fundamentals of making three basic garments—a top, a pair of shorts, and a skirt.

Paper with concealed wire-o and patterns; 160 pages; 9 x 9½
Full-color
\$22.95 US
ISBN 978-1-61212-860-3

Includes fabric labels



Sewing School® Box Set

AMIE PETRONIS PLUMLEY & ANDRIA LISLE

This special box set features the bestsellers *Sewing School®* and *Sewing School® 2*, plus bonus "Made By" iron-on fabric labels for personalizing kids' creations.

Two paperbacks with concealed wire-o and a set of iron-on fabric labels in a slipcase, shrink-wrapped; 304 pages; Full-color
\$40.00 US
ISBN 978-1-63586-117-4

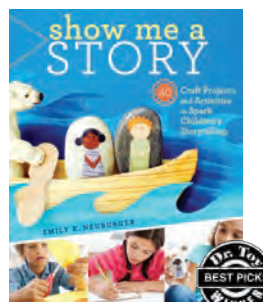

Show Me a Story

EMILY K. NEUBURGER

These 40 inventive craft projects and activities spark creativity and encourage children to let their imaginations run wild as they write and tell original stories.

Paper; 144 pages; 8 x 10
Full-color
\$16.95 US
ISBN 978-1-60342-988-7

Hardcover;
\$26.99 US
ISBN 978-1-63586-360-4

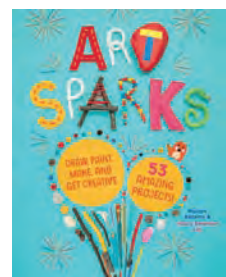

Art Sparks

MARION ABRAMS & HILARY EMERSON LAY

Every kid can be an artist with this rich collection of 53 inspiring art projects curated by two art educators with decades of experience. Working with basic art supplies—from paint, markers, paper, and glue to household finds like cardboard boxes and fabric scraps—children learn that if they can imagine it, they can create it!

Paper; 176 pages; 8 x 10
Full-color
\$16.95 US
ISBN 978-1-63586-118-1

Hardcover; 136 pages; 7 x 10
Full-color
\$18.99 US
ISBN 978-1-63586-360-4

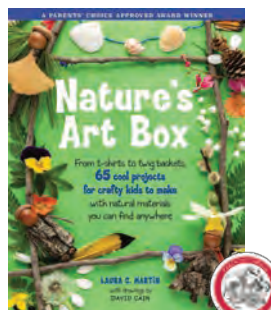

Nature's Art Box

LAURA C. MARTIN

Kids can make these 65 projects using materials found just about anywhere. Directions show how to make paints and inks from flowers and other plants; use shells, moss, and cones to embellish large objects; and make natural dyes to color T-shirts.

Paper; 224 pages; 8½ x 10½
Full-color
\$16.99 US
ISBN 978-1-58017-490-9

Hardcover; 144 pages; 7 x 10
Full-color
\$26.99 US
ISBN 978-1-63586-623-0

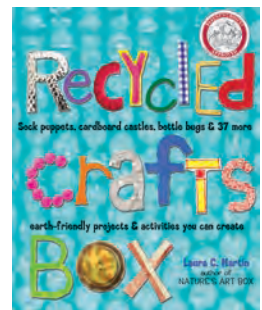

Recycled Crafts Box

LAURA C. MARTIN

With materials found in a typical recycling bin, kids can make 40 great craft projects. Children will also have fun reading about the history of rubbish and learning what they can do to make a difference by recycling.

Paper; 96 pages; 8½ x 10½
Full-color
\$10.95 US
ISBN 978-1-58017-522-7

Hardcover; 144 pages; 8 x 10
Full-color
\$16.95 US
ISBN 978-1-63586-035-1



Make Music!

NORMA JEAN HAYNES, ANN SAYRE WISEMAN & JOHN LANGSTAFF

This playful guide encourages kids to discover music—no lessons or special talents required! They'll explore beats; create "found sounds" with household items; compose, perform, and record their own melodies; and even craft their own instruments.

Paper; 144 pages; 8 x 10
Full-color
\$16.95 US
ISBN 978-1-63586-035-1



Stitch Camp

NICOLE BLUM & CATHERINE NEWMAN

Today's thriving maker culture is rubbing off on kids, who are hungry to create or hack stylish wearables, toys, and gifts. This lively guide teaches kids how to sew, knit, crochet, felt, embroider, and weave. Eighteen original projects give them plenty of opportunities to practice, improvise, and make.

Paper with flaps and 2 sheets of punch-out gift tags; 208 pages; 8 x 10
Full-color
\$19.99 US
ISBN 978-1-61212-750-7



Girls' Home Spa Lab

MAYA PAGÁN

Packed with all-natural recipes, activities, and tips for relaxation, this fun guide gives tween girls healthy ways to build essential self-care routines into daily life, from homemade bodycare formulas to easy yoga poses, sleep tea blends, and natural remedies.

Paper; 160 pages; 8 x 10
Full-color
\$16.95 US
ISBN 978-1-61212-964-8



Journal Sparks

EMILY K. NEUBURGER

These 60 interactive prompts, activities, and art how-tos provide endless inspiration for filling the blank page in fresh, inviting ways.

Paper; 164 pages; includes 2 sticker sheets, 3 sheets of paper punch-outs, and 10 sheets of decorative collage paper; 7½ x 9½
Full-color
\$18.99 US
ISBN 978-1-61212-652-4



The Kids' Building Workshop

J. CRAIG & BARBARA ROBERTSON

Boys and girls love woodworking projects! But most kids (and many parents) lack woodworking skills. In this lively, fully photographed and illustrated book, fun projects teach what every woodworker needs to know.

Paper; 144 pages; 8½ x 10½
Two-color
\$16.95 US
ISBN 978-1-58017-488-6



Make Your Own Money

TY ALLAN JACKSON

This lively, easy-to-read guide to financial literacy and entrepreneurship for young readers is narrated by the money-savvy fictional character Danny Dollar and features fun, graphic novel-style illustrations. Kids are empowered to dream big, be smart with money, and even start a business—all in a language they can understand.

Paper; 128 pages; 6½ x 9
Full-color
\$14.99 US
ISBN 978-1-63586-371-0

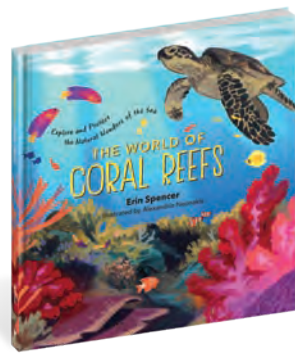

"An exciting guide for the next generation of ocean explorers, balancing the awe and wonder of the coral reef ecosystem with easy-to-understand science and facts that explore their importance and the immense threats they're currently facing."

—Joe Grabowski, Director and Founder of Exploring by the Seat of Your Pants and National Geographic Explorer

The World of Coral Reefs

ERIN SPENCER
The World of Coral Reefs introduces children ages 7 to 10 to the rich diversity of life that is supported by endangered coral reefs. From the anatomy and life cycle of coral to the many fish and other marine life that flourish in the reef, this colorful, large-format nature book takes kids on a wonder-filled underwater tour, with stunning illustrations that will engage and educate the next generation of environmental caretakers.

■ For ages 7-10
Hardcover; 48 pages; 11¼ x 11¼
 Full-color
\$16.95 US
 ISBN 978-1-63586-337-6



Monarch Butterflies

ANN HOBBIÉ
 This engaging book gives young readers a detailed look at the monarch's life cycle, anatomy, migration to Mexico, and cultural significance in Day of the Dead celebrations. With illustrations and fascinating facts, children learn how to create critical habitat, participate in citizen science efforts, support butterfly conservation organizations, and more.

Hardcover; 48 pages; 11 x 11
 Full-color
\$17.99 US
 ISBN 978-1-63586-289-8



Raptor!

CHRISTYNA M. LAUBACH, RENÉ LAUBACH & CHARLES W. G. SMITH
 This guide shows kids how to locate raptors in the wild and explores the mysteries of raptor flight, hunting strategies, and behavior.

■ For ages 8-12
 ■ **72,000 COPIES IN PRINT**
Paper with flaps; 128 pages; 7½ x 11
 Full-color
\$16.99 US
 ISBN 978-1-58017-445-9



What's That Bird?

JOSEPH CHOINIÉRE & CLAIRE MOWBRAY GOLDING
 The perfect tool for beginning bird enthusiasts of all ages, this easy-to-use guide offers basic bird literacy while teaching the best ways to observe and identify 30 common feathered friends. Additional fun facts highlight more than 20 incredible birds, including the fastest runner (wild turkey) and highest flier (bar-headed goose).

■ For ages 8-12
Paper; 128 pages; 7½ x 11
 Full-color
\$14.95 US
 ISBN 978-1-58017-554-8

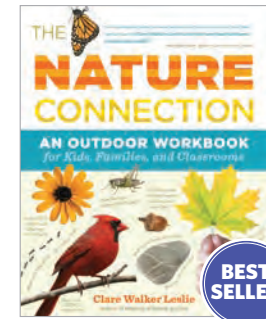

The Nature Connection

CLARE WALKER LESLIE
 Dozens of interactive projects keep kids engaged and learning in every season, with prompts to write a poem, record daily sunrise and sunset times, draw a local map, keep a moon journal, and collect leaves to identify.

■ For ages 8-12
 ■ Teachers' Choice Award for the Family
 ■ **84,000 COPIES IN PRINT**
Paper; 304 pages; 7¼ x 9¼
 Two-color
\$16.95 US
 ISBN 978-1-60342-531-5



Put On Your Owl Eyes

DEVIN FRANKLIN
 In this highly interactive nature education guide, 15 exploratory exercises help children hone their senses and observation skills and discover how much they can learn about their outdoor environment when they stop, look, and listen.

■ For ages 8-13
Paper; 160 pages; 7¼ x 9¼
 Full-color
\$16.95 US
 ISBN 978-1-63586-022-1



Wilderness Adventure Camp

FRANK GRINDROD
 Whether in the rugged backcountry or a suburban backyard, kids can master the wilderness skills necessary for a safe outdoor experience with this bushcraft handbook. They'll learn to pack for the outdoors, navigate using a map and a compass, choose and set up a campsite, handle a knife, build a fire, tie knots, make a lean-to out of sticks and leaves, and cook over an open fire.

Paperback; 160 pages; 7¼ x 9¼
 Full-color
\$16.95 US
 ISBN 978-1-63586-152-5

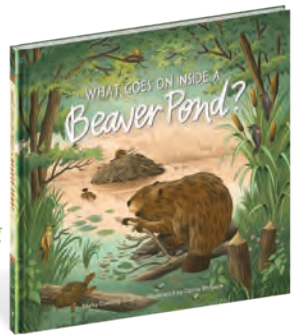

"Chocked full of facts and observations rendered in vibrant comic-style panels, this narrative nonfiction book provides lots to chew on for builders and budding aquatic naturalists."

—Orion

What Goes on Inside a Beaver Pond?

BECKY CUSHING GOP
 This stunning book takes kids ages 8 to 10 on a journey through a year in the life of a young beaver. Throughout the seasons, vibrant illustrations and descriptions reveal the hidden inner-workings of a beaver lodge and what daily life is like within a beaver colony. Educational side panels enhance the story with details about beaver behavior and anatomy.

■ National Outdoor Book Award Winner
 ■ John Burroughs Association Riverby Award Winner
 ■ Nautilus Book Awards, Silver Winner
Hardcover; 48 pages; 11¼ x 11¼
 Full-color
\$18.99 US
 ISBN 978-1-63586-527-1



Sky Gazing

MEG THACHER
 Curious kids will learn to observe the sky with the naked eye and understand the science behind what they see. Along with discovering how objects like Earth's moon were formed and the "why" behind astronomical phenomena such as eclipses and meteor showers, young sky gazers will learn how to find planets (no binoculars or telescopes required!), spot constellations, track the cycles of the sun and moon, and more.

■ For ages 8-13
Hardcover with glow-in-the-dark ink on cover; 132 pages; 11 x 11
 Full-color
\$22.99 US
 ISBN 978-1-63586-096-2



Owling

MARK WILSON
 Wildlife photojournalist and owl rehabilitator Mark Wilson invites young readers to take an up-close look at the world of owls. Kids will learn about the birds' silent flight, remarkable eyes and ears, and haunting calls while seeing owls in action through dramatic photographs of 19 North American species.

■ For ages 8-12
 ■ AAAS/Subaru Award
Hardcover with glow-in-the-dark ink on cover; 120 pages; 11 x 11
 Full-color
\$19.99 US
 ISBN 978-1-61212-962-4



Backyard Adventure

AMANDA THOMSEN
 With found and repurposed materials and a dash of wild imagination, kids can make their own fun! These 51 outdoor projects for open-ended play show them how to build an adventure course, weave a secret hideaway, and more.

■ For ages 6 and up
Paper; 160 pages; 8 x 10
 Full-color
\$16.95 US
 ISBN 978-1-61212-920-4



Gardening with Emma

EMMA BIGGS WITH STEVEN BIGGS
 Thirteen-year-old Emma Biggs shows young gardeners how to grow healthy food, raise cool plants, and cultivate fun! With tips for how to grow a flower stand garden, suggestions for veggies from tiny to colossal, and ways to make play spaces among the plants, she offers practical, entertaining advice and inspiration.

■ For ages 8-12
 ■ National Parenting Product Award
Paper; 144 pages; 8 x 10
 Full-color
\$19.99 US
 ISBN 978-1-61212-925-9



We Garden Together

JANE HIRSCHI THE EDUCATORS AT CITYSPROUTS
 This introductory garden book features hands-on planting and growing activities that can be done in a small yard, classroom, or community garden. Written by the staff of City Sprouts, each activity—encourages kids to roll up their sleeves and learn about seeds, planting, and gardening.

■ For ages 3-6
Hardcover; 48 pages; 8 x 9
 Full-color
\$12.99 US
 ISBN 978-1-63586-545-5

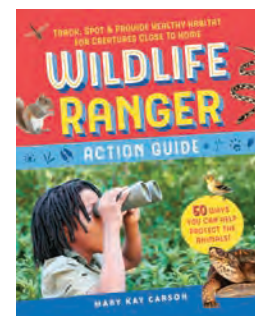

Wildlife Ranger Action Guide

MARY KAY CARSON
 Children can take an active role in protecting the animals and insects they love, starting in their own backyards, with dozens of hands-on activities, habitat creation projects, and photographic field guides to North American wildlife.

■ For ages 8 and up
Paper; 176 pages; 8 x 10
 Full-color
\$18.95 US
 ISBN 978-1-63586-106-8



Thank You, Farm

Featuring the adorable illustrations of Jade Orlando, *Thank You, Farm* invites babies and toddlers to say thank you to their animal friends and all the gifts that come from the farm. From thanking cows for their milk to thanking the garden for yummy carrots, this sweet book teaches appreciation to the youngest readers.

■ For ages 0-3
Board book; 22 pages; 6 x 6
 Full-color
\$6.95 US
 ISBN 978-1-63586-394-9



Thank You, Tree

Fiona Lee's charming illustrations invite little ones to celebrate a tree, learn its name, and say thank you for the tree's joyful, natural gifts. From thanking a magnolia tree for its pink blossoms to thanking an aspen for a secret hiding place, this book teaches pre-readers to appreciate trees.

■ For ages 0-3
Board book; 22 pages; 6 x 6
 Full-color
\$6.95 US
 ISBN 978-1-63586-426-7

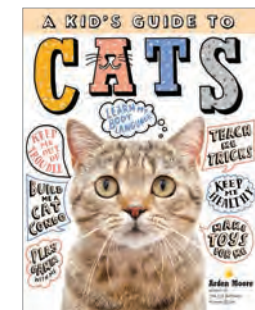

A Kid's Guide to Cats

ARDEN MOORE
 Combining humor with practical advice, this lively guide teaches young cat lovers how to read cat body language, litter box protocol, the history of cat-human relationships, and why cats purr. Features include "Ask the Vet" Q&As, trivia quizzes, and more.

■ For ages 0-3
Paper; 144 pages; 7 x 9
 Full-color
\$14.95 US
 ISBN 978-1-63586-101-3
Hardcover;
\$25.00 US
 ISBN 978-1-63586-102-0



A Kid's Guide to Dogs

ARDEN MOORE
 Fun, informative, and full of colorful photos and illustrations, this canine care handbook teaches kids how to decode dog body language, perform a wellness checkup, and train a new pup. Features include "Ask the Vet" Q&As, trivia quizzes, easy crafts, and more.

■ For ages 0-3
Paper; 144 pages; 7 x 9
 Full-color
\$14.95 US
 ISBN 978-1-63586-098-6
Hardcover;
\$24.95 US
 ISBN 978-1-63586-099-3



Cherry Hill's Horse Care for Kids

These equine care essentials will groom kids into responsible and successful horse or pony owners. Beginning with how to match the right horse to the rider and progressing through safe handling, grooming, feeding, stabling, and much more, this is the comprehensive horse-care book every young equestrian will use for years.

- For ages 8-14
- The ASPCA Henry Bergh Children's Book Honor

Paper; 128 pages; 7½ x 9½
Full-color
\$16.95 US
ISBN 978-1-58017-407-7



Horse Play!

DEANNA F. COOK & KATIE CRAIG

Horse-loving kids will treasure this kit-in-a-book, with stickers, pop-out pieces, colorful illustrations, fascinating insights into horse behavior, and creative craft and decorating projects for turning a bedroom into a horsey haven, planning a horse-themed slumber party, and more!

- For ages 8-12
- Gold Mom's Choice Award
- National Parenting Product Award

Paper with partially concealed wire-o, punch-out cards, stencil, stickers, and pull-out poster; 68 pages; 7 x 9
Full-color
\$12.95 US
ISBN 978-1-61212-759-0

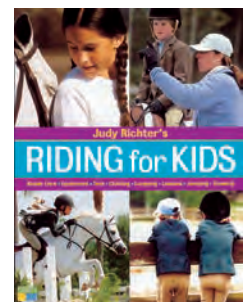

Riding for Kids

JUDY RICHTER

The perfect companion to lessons in the ring, here is the learn-to-ride program every young equestrian will refer to again and again. Step-by-step instructions and photos guide kids on everything from proper riding attire and tacking up the horse to jumping and showing.

- For ages 9-12
- 41,000 COPIES IN PRINT**

Paper; 144 pages; 7½ x 9½
Full-color
\$16.95 US
ISBN 978-1-58017-510-4



Jumping for Kids

LESLEY WARD

Jumping is a thrilling accomplishment for young riders. Covering all the safety and technique fundamentals, this complete learn-to-jump program features photos, diagrams, charts, and plenty of friendly, encouraging advice.

- For ages 10-14

Paper; 144 pages; 7½ x 9½
Full-color
\$16.95 US
ISBN 978-1-58017-672-9

**BEST-SELLING SERIES
GAMES & PUZZLES FOR KIDS**

425,000 COPIES IN PRINT

Each Games & Puzzles book is filled with 100 brainteasers, picture puzzles, word searches, mazes, and riddles that keep kids playing and laughing for hours! Educational as well as fun, these books help kids develop problem-solving skills while uncovering fascinating facts about their favorite animals.

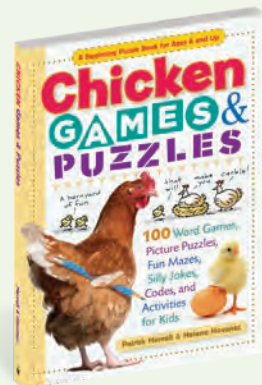

Chicken Games & Puzzles

PATRICK MERRELL & HELENE HOVANEC

- For ages 6-10

Paper; 144 pages; 8 x 10½
Illustrations throughout
\$9.95 US
ISBN 978-1-61212-087-4

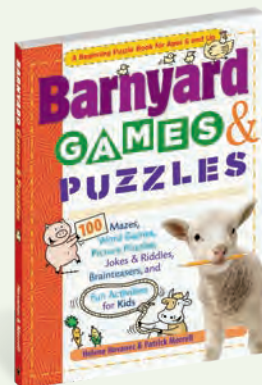

Barnyard Games & Puzzles

HELENE HOVANEC & PATRICK MERRELL

- For ages 6-10
- 35,000 COPIES IN PRINT**

Paper; 144 pages; 8 x 10½
Illustrations throughout
\$9.95 US
ISBN 978-1-58017-630-9

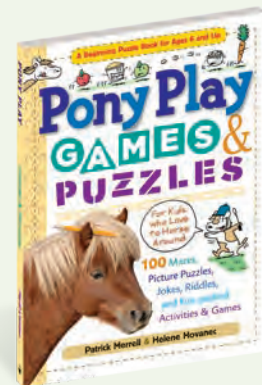

Pony Play Games & Puzzles

PATRICK MERRELL & HELENE HOVANEC

- For ages 6-10
- 37,000 COPIES IN PRINT**

Paper; 144 pages; 8 x 10½
Illustrations throughout
\$9.95 US
ISBN 978-1-60342-063-1

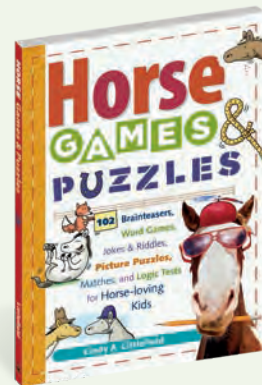

Horse Games & Puzzles

CINDY A. LITTLEFIELD

- For ages 8-12

Paper; 144 pages; 8 x 10½
Illustrations throughout
\$9.95 US
ISBN 978-1-58017-538-8

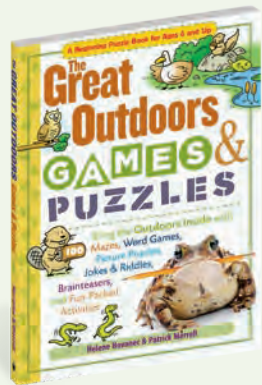

The Great Outdoors Games & Puzzles

HELENE HOVANEC & PATRICK MERRELL

- For ages 8-12
- 58,000 COPIES IN PRINT**

Paper; 144 pages; 8 x 10½
Illustrations throughout
\$9.95 US
ISBN 978-1-58017-679-8

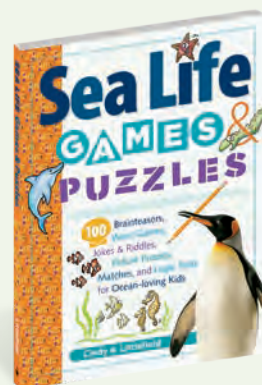

Sea Life Games & Puzzles

CINDY A. LITTLEFIELD

- For ages 8-12
- 55,000 COPIES IN PRINT**

Paper; 144 pages; 8 x 10½
Illustrations throughout
\$9.95 US
ISBN 978-1-58017-624-8

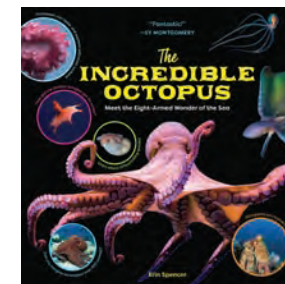

Incredible Octopus

ERIN SPENCER

This fascinating book invites kids ages 7 and up to explore the behavior and intelligence of this remarkable creature of the deep. Readers are introduced to the biology of the octopus, from its 3 hearts and 9 brains to suction cups and how they work and learn all about what it's like to be an octopus.

- For ages 7-10

Hardcover; 72 pages; 11 x 11
Full-color
\$19.99 US
ISBN 978-1-63586-628-5

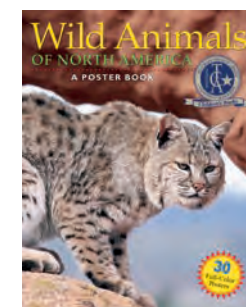

Wild Animals of North America

KARL MEYER

From coast to coast and from Canada to Mexico, North America is home to many truly amazing creatures. Here are 30 engaging, action-packed pull-out posters capturing the lives and habitats of birds, mammals, and reptiles across the wilds of the North American continent.

- For ages 7-12
- Teachers' Choice Children's Book Award

Paper; 64 pages; 9½ x 12
Full-color
\$9.95 US
ISBN 978-1-58017-643-9



Under the Sea Poster Book

Children can bring home the magical experience of their first trip to the aquarium, with its scary sharks, touchable tide pools, and brightly colored marine life. Thirty full-color pull-out portraits of fantastic sea creatures feature the ocean residents kids love, plus all the fun facts that make each creature unique and exciting.

- For ages 7-12

Paper; 64 pages; 9½ x 12
Full-color
\$9.95 US
ISBN 978-1-58017-623-1



The Horse Breeds Poster Book

PHOTOGRAPHY BY BOB LANGRISH

Suitable for hanging on bedroom walls, in school lockers, or even in barns, these 30 posters show horses in a range of colors and sizes, at work and in competition. Facts about the pictured horse breeds are included on the back of each poster.

- For ages 7-12

Paper; 64 pages; 9½ x 12
Full-color
\$10.95 US
ISBN 978-1-58017-507-4



Wild for Horses

This exquisite gift package features 24 full-color ready-to-hang posters that show off the noble beauty of horses. Two dozen punch-out flash cards—complete with stunning photos and fun facts—add an interactive element, and two 12 x 30 pull-out panoramic posters further illustrate the grandeur of horses.

- For ages 7-12

Paper; 50 plus 2 sheets of flash cards and 2 gatefold posters pages; 10 x 12
Full-color
\$12.95 US
ISBN 978-1-61212-888-7

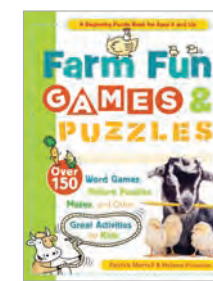

Farm Fun Games & Puzzles

From acclaimed puzzle creators Patrick Merrell and Helene Hovanec comes a barnyard full of fun farm-themed puzzles. From mazes and picture puzzles to brainteasers, word searches, jokes, riddles, and more, 200 puzzles will keep kids screen-free and entertained for hours.

- For ages 6-10

Paper; 240 pages; 7 x 9½
One-color illustrations throughout
\$12.95 US
ISBN 978-1-63586-522-6

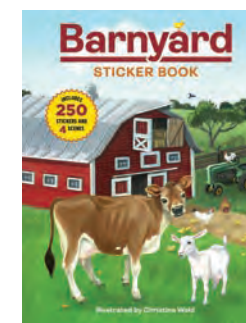

Barnyard Sticker Book

More than 250 colorful stickers capture every aspect of the farm, including all the animals, the equipment, tools, and supplies. There are four fold-out scenes on the laminated covers: the full farm, a barn interior, an animal pen, and a chicken coop.

- For ages 4-8

Paper; 12 pages with laminated gate-fold covers; 8½ x 10½
Full-color
\$7.99 US
ISBN 978-1-63586-494-6



A Kid's Guide to Keeping Chickens

MELISSA CAUGHEY

Kids can learn practical tips on housing, food, and equipment before bringing home their first chicks. Egg-centric dishes and crafts offer hours of fun.

- For ages 8-12
- AAAS/Subaru Award
- Teachers' Choice Award for the Family
- 65,000 COPIES IN PRINT**

Paper with pull-out poster; 144 pages; 7½ x 9½
Full-color
\$16.95 US
ISBN 978-1-61212-418-6



Creatures of the Ocean Sticker Poster

Kids ages 4 and up will love following the clues to match the creature to its place on the poster. The completed poster, measuring 15 x 28 inches, makes a stunning piece of ocean wall art.

- For ages 4-8

Paper; 14 pages includes 5 sticker sheets and a 15 x 28.5 poster; 8 x 10
Full-color
\$12.99 US
ISBN 978-1-63586-620-9

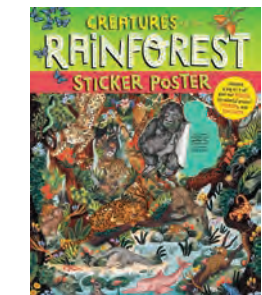

Creatures of the Rainforest Sticker Poster

This big, colorful poster activity book invites kids ages 4-8 to complete the scene by adding 50 sticker puzzle pieces, all featuring creatures who inhabit rainforests around the world.

- For ages 4-8

Paper; 14 pages includes 5 sticker sheets and a 15 x 28.5 poster; 8 x 10
Full-color
\$12.99 US
ISBN 978-1-63586-621-6



“If you’re new to knitting socks, there’s no easier way to get on your feet. The patterns that demonstrate the technique are varied, beautiful, and inspiring.”

—Kay Gardiner and Ann Shayne, Modern Daily Knitting



“One of my favorite voices in the knitting world brings us this clever take on socks that eliminates the dreaded second sock syndrome.”

—Clara Parkes, New York Times bestselling author of *Knitlandia* and *The Knitter’s Book of Socks*



Perfect for beginning knitters, Safiyyah Talley developed this technique specially for her new knitter classes. Featuring seven basic styles, with many variations, knitters will find 21 different patterns to choose from.

Knit 2 Socks in 1

SAFIYYAH TALLEY

Designer Safiyyah Talley shares her clever solution to knitting two socks at once; knit one BIG sock and then divide it into two! Knitters can choose from 21 different sock styles, featuring a wide range of stitch patterns, design elements, levels of difficulty, and sizes ranging from child to adult. Knit 2 Socks in 1 is a tried-and-true sock-knitting technique that allows knitters from all backgrounds to join in on the fun.

Hardcover; 160 pages; 7 x 9
Full-color
\$16.95 US
ISBN 978-1-63586-407-6

BEST-SELLING AUTHOR MARGARET RADCLIFFE



“An amazing book on knitting with various colors of yarn.”

—The Detroit News

The Essential Guide to Color Knitting Techniques

Here is the go-to reference for knitters looking to expand their colorwork skills or polish their techniques, from selecting harmonious colors to managing multiple balls of yarn or changing colors mid-row.

Paper; 320 pages; 8½ x 10½
Full-color
\$26.99 US
ISBN 978-1-61212-662-3



“A must-have for knitters of all levels who want to understand how to alter, control, and personalize their work.”

—Publishers Weekly

The Knowledgeable Knitter

This definitive reference helps knitters of all levels produce better-fitting garments and more professional-looking projects, with in-depth instruction on all the essential techniques.

Paper; 296 pages; 8½ x 10½
Full-color
\$24.95 US
ISBN 978-1-61212-040-9

Hardcover;
\$34.95 US
ISBN 978-1-61212-414-8



“Like having the wisest, least judgy knitting teacher right in your project bag.”

—Vogue Knitting

Circular Knitting Workshop

Fair Isle, twined, helix, tubular, double knitting, and other classic circular knitting techniques are detailed in step-by-step photographic sequences, in addition to instructions for converting any straight-needle pattern for use with circular needles. This is a complete course in one book, suitable even for beginners.

■ **60,000 COPIES IN PRINT**
Paper; 320 pages; 8½ x 10½
Full-color
\$29.95 US
ISBN 978-1-60342-999-3



2-at-a-Time Socks

MELISSA MORGAN-OAKES

Knitting one sock is fun and rewarding, but finishing the second one can be boring. This easy-to-learn technique lets stitchers work on two socks at one time. Step-by-step photographs illustrate the method of casting on and knitting two socks together on one long circular needle.

Hardcover with concealed wire-o;
144 pages; 7 x 9
Full-color
\$16.95 US
ISBN 978-1-58017-691-0



Toe-Up 2-at-a-Time Socks

MELISSA MORGAN-OAKES

Toe-up knitting allows the knitter to try on socks along the way and avoid using Kitchener stitch to finish off the toes. This book includes 15 original sock designs for men, women, children, and babies.

■ **99,000 COPIES IN PRINT**
Hardcover with concealed wire-o;
176 pages; 7 x 9
Full-color
\$16.95 US
ISBN 978-1-60342-533-9



Knit Your Socks on Straight

ALICE CURTIS

Finally, here is a way to knit socks on straight needles! With step-by-step visual instructions for this groundbreaking technique, along with 20 unique patterns that creatively incorporate the seam into the design, this book features a variety of yarn weights and motifs, plus instructions for a wide range of sizes.

Hardcover with concealed wire-o;
144 pages; 7 x 9
Full-color
\$17.00 US
ISBN 978-1-61212-008-9

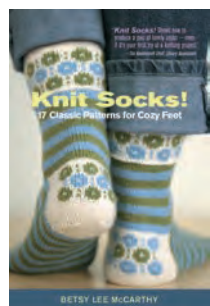

Knit Socks!

BETSY LEE MCCARTHY

With these cozy, colorful sock patterns and simple instructions, even beginners can make great socks on the first try. Friendly advice on topics such as choosing yarn and adapting patterns to any type of needle gives knitters the confidence to get started and the skills to tackle more challenging projects.

Paper; 176 pages; 6 x 9
Full-color
\$16.99 US
ISBN 978-1-60342-549-0

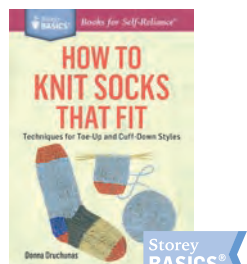

How to Knit Socks That Fit

DONNA DRUCHUNAS

Small and portable, sock projects are a perennial favorite of knitters of all levels, but the results are too often disappointing. This book reveals foolproof techniques for knitting socks that look great and fit well, including both toe-up and cuff-down approaches and three different heel styles.

Paper; 128 pages; 5 x 7
Illustrations throughout
\$8.95 US
ISBN 978-1-61212-541-1



Knit Christmas Stockings, 2nd Edition

EDITED BY GWEN W. STEEGE

Even beginning knitters can create treasured and timeless holiday items. This book explains techniques for felting and blocking and offers basic knitting instructions along with 19 project patterns for festive stockings, ornaments, and decorations.

Paper; 136 pages; 6 x 9
Full-color
\$12.95 US
ISBN 978-1-61212-252-6



The Knitting Answer Book, 2nd Edition

MARGARET RADCLIFFE

This pocket reference offers tips for measuring gauge on tricky fabrics, details how to adjust patterns to fit, guides readers on the best cast ons and bind offs for specific situations, and more!

Flexibind with cloth spine;
440 pages; 4½ x 6½
Two-color
\$14.95 US
ISBN 978-1-61212-404-9

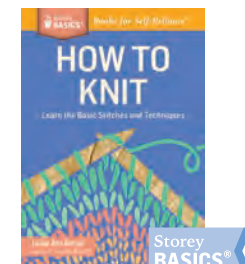

How to Knit

LESLIE ANN BESTOR

With this clearly illustrated guide, novice knitters will cast on with confidence and master the basics of knitting, from foundational stitches and shaping work to troubleshooting, casting off, and finishing.

Paper; 112 pages; 5 x 7
Illustrations throughout
\$9.95 US
ISBN 978-1-61212-359-2



Knitting Modular Shawls, Wraps, and Stoles

MELISSA LEAPMAN

Practical and versatile, shawls are an ever-popular knitting project. With noted designer Melissa Leapman's innovative technique, knitters can join together multiple knit triangles to create fashionable wraps in square, rectangular, trapezoidal, and semicircular shapes. This easy and customizable approach offers knitters endless flexibility in design and yarn choice, and charted patterns for 185 different stitches provide readers with the tools to select their favorite motif for the main fabric of their shawl.

Hardcover; 288 pages; 8½ x 10½
Full-color
\$32.00 US
ISBN 978-1-61212-996-9

“Melissa Leapman combines the plug-and-play ease she has brought to sweaters with an endlessly creative stitch selection to create the perfect book for every shawl knitter.”

—Patty Lyons, knitwear designer and teacher

BEST-SELLING SERIES ONE-SKEIN WONDERS®

OVER HALF A MILLION COPIES IN PRINT

It takes so little yarn to make something wonderful. Each One-Skein Wonders book has 101 projects that celebrate a variety of yarns and techniques for making beautiful creations—all with a single skein.

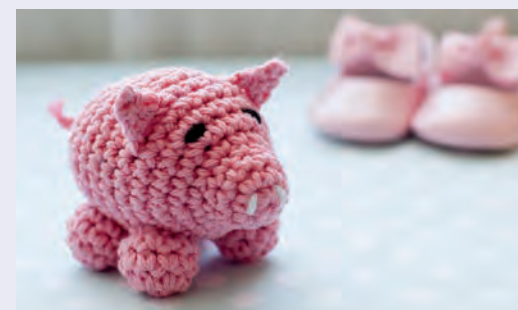

One-Skein Wonders®

EDITED BY JUDITH DURANT

Every knitter's closet has skeins of orphan yarn that never seem to get used. Now those skeins have a purpose, with 101 patterns for hats, mittens, scarves, bags, socks, baby sweaters, and more.

Paper; 240 pages; 8 x 8½
Two-color with 24-page full-color insert
\$19.95 US
ISBN 978-1-58017-645-3



101 Designer One-Skein Wonders®

EDITED BY JUDITH DURANT

For every lonely skein of yarn there is a perfect small project. Here, knitwear designers offer their favorite one-skein patterns for hats, scarves, bags, shawls, pillows, and other fun items that knit up in no time.

Paper; 256 pages; 8 x 8½
Two-color with 32-page full-color insert
\$18.95 US
ISBN 978-1-58017-688-0



Sock Yarn One-Skein Wonders®

EDITED BY JUDITH DURANT

Sock yarn isn't just for socks anymore! Knitters can use this colorful, sturdy yarn to new ends, with original patterns for baby clothes, warm mittens and hats, beautiful scarves, jewelry, bags, cozies, and items for the home.

Paper; 288 pages; 8 x 8½
Full-color
\$19.95 US
ISBN 978-1-60342-579-7



Lace One-Skein Wonders®

EDITED BY JUDITH DURANT

Lace adds delicate beauty to knitted items and is an addictive technique for knitters. This book includes 101 lace projects for single skeins of yarn, along with tips to help knitters expand their lace repertoire.

Paper; 304 pages; 8 x 8½
Full-color
\$18.95 US
ISBN 978-1-61212-058-4



One-Skein Wonders® for Babies

EDITED BY JUDITH DURANT

From soft, cozy hats to sure-to-become heirloom blankets, knitters of every level will find something adorable to make in this collection of original patterns for new arrivals and active toddlers.

Paper; 288 pages; 8 x 8½
Full-color
\$24.99 US
ISBN 978-1-61212-480-3



Crochet One-Skein Wonders® for Babies

EDITED BY JUDITH DURANT & EDIE ECKMAN

This collection of irresistibly cute projects for dressing and accessorizing infants and toddlers features original patterns for everything from hats and caps to socks and booties, tops and dresses, blankets, wraps, and soft toys.

Paper; 288 pages; 8 x 8½
Full-color
\$18.95 US
ISBN 978-1-61212-576-3



Crochet One-Skein Wonders®

EDITED BY JUDITH DURANT & EDIE ECKMAN

Organized by yarn weight, this stunning collection of projects makes it easy for crocheters to put single skeins to use, making jewelry, gloves, hats, home décor, baby clothes, stuffed toys, and more!

Paper; 288 pages; 8 x 8½
Full-color
\$19.95 US
ISBN 978-1-61212-042-3



"This is a great reference for the knitter looking to customize her own projects, and is an ideal companion for anyone who dares to try her own hand at design."

—The Oregonian

Cast On, Bind Off

LESLIE ANN BESTOR

This one-of-a-kind reference presents more than 50 ways to start and finish knitting projects. Detailed instructions for each technique are combined with step-by-step photography so that nothing is left to chance. At-a-glance charts identify the right cast on or bind off for various types of knitting, as well as cast on/bind off pairs that work well together.

Paper with partially concealed wire-o;

216 pages; 5½ x 7

Full-color

\$18.99 US

ISBN 978-1-60342-724-1



Includes Bonus Online Tool

Design Your Own Crochet Projects

SARA DELANEY

Today's avid crocheters are eager to move beyond the granny square. With Sara Delaney's unique, flexible formulas, crocheters of all levels learn how easy it is to design scarves, cowls, fingerless mitts, mittens, gloves, hats, and socks using their favorite yarn and stitch pattern. The fill-in-the-blank templates and stitch dictionary make it possible to create one-of-a-kind accessories that fit perfectly.

Hardcover with concealed wire-o;

256 pages; 7 x 9

Full-color

\$18.95 US

ISBN 978-1-61212-658-6

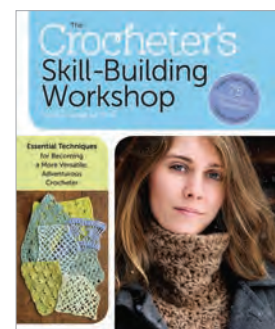

The Crocheter's Skill-Building Workshop

DORA OHRENSTEIN

This surprising range of stitch patterns and shapes shows off the fresh, fashionable face of crochet. The book features 75 stitch-along swatches, plus projects for using the swatch techniques to make a hat, shawl, neck warmer, bag, and scarf.

Paper; 256 pages; 8¼ x 10

Full-color

\$19.95 US

ISBN 978-1-61212-246-5

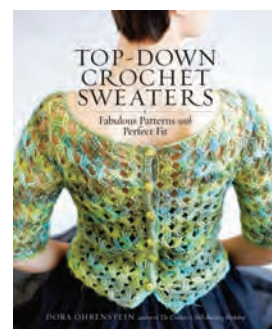

Top-Down Crochet Sweaters

DORA OHRENSTEIN

Making garments from the top down is a favorite technique among knitters that allows them to test and adjust the fit as they go. Now, the first pattern book of its kind lets crocheters use the same approach. These 14 sophisticated designs are sure to flatter bodies of all shapes and sizes, and instructions on how and why to adjust the patterns will ensure an exquisite customized fit.

Paper; 176 pages; 8¼ x 10

Full-color

\$19.99 US

ISBN 978-1-61212-610-4



At Knit's End

STEPHANIE PEARL-MCPHEE

This humorous book will have obsessive knitters—defined as anyone who has snuck new yarn purchases into the house, uttered the words “just one more row,” or planned a vacation around yarn store locations—laughing in relieved recognition.

■ **129,000 COPIES IN PRINT**

Paper; 320 pages; 4 x 6

\$12.99 US

ISBN 978-1-58017-589-0



Things I Learned from Knitting . . . whether I wanted to or not

STEPHANIE PEARL-MCPHEE

Age-old aphorisms like “Patience is a virtue” and “There’s no accounting for taste” take on new, fresh, and funny meaning when the best-selling Yarn Harlot applies them to the knitting universe.

■ **51,000 COPIES IN PRINT**

Hardcover with jacket; 160 pages;

4¼ x 6¼

Two-color

\$10.95 US

ISBN 978-1-60342-062-4

BEST-SELLING AUTHOR EDIE ECKMAN



"This encyclopedia of cute crocheted borders, which range from simple to extravagant, really expands the options of anyone looking to add a little flair to their knit, crocheted, and even sewn projects."

—Debbie Stoller, author of the Stitch 'n Bitch series

Around the Corner Crochet Borders

A crochet border is the perfect finishing touch on the edges of any fiber project, but creating one often means shaping the edging around an unforgiving 90-degree angle. It's no easy task, but Edie Eckman guides you through it with style and poise. This collection includes 150 vibrant crochet frames to suit every fiber need, with color photographs by John Polak that showcase the beautiful details of each technique. Now painless, marvelous crochet borders are just around the corner!

■ **146,000 COPIES IN PRINT**

Paper; 320 pages; 8½ x 6

Full-color

\$18.95 US

ISBN 978-1-60342-538-4



"You may never want to put your crochet book down again, at least not until you've created one of the 144 fun-to-make colorful squares, rectangles, circles, hexagons and stars featured in the spiral-bound book."

—Detroit News

Beyond the Square Crochet Motifs

Move beyond granny squares and get ready for crocheted circles, triangles, hexagons, and stars. Edie Eckman opens up the door to crocheting creativity with more than 140 motifs of every shape and size. Embellish your clothing, linens, housewares, and bags with colorful patterns as you put odd yarn leftovers to good use. Step-by-step instructions and color photographs provide the building blocks to limitless possibilities.

■ **178,000 COPIES IN PRINT**

Hardcover with concealed wire-o;

208 pages; 7 x 9

Full-color

\$20.00 US

ISBN 978-1-60342-039-6



Christmas Crochet for Hearth, Home & Tree

Readers can crochet contemporary stockings, adorable and festive ornaments, a tree skirt, and other seasonal decorations for the home using these 18 easy patterns.

Paper; 184 pages; 6 x 9

Full-color

\$14.95 US

ISBN 978-1-61212-329-5



Connect the Shapes Crochet Motifs

Many crocheters love to stitch motifs but dread the process of joining them. Detailed instructions for creative joining techniques show how to combine multiples of a motif to form a whole new pattern.

■ **48,000 COPIES IN PRINT**

Hardcover with concealed wire-o;

272 pages; 7 x 10

Full-color

\$24.00 US

ISBN 978-1-60342-973-3

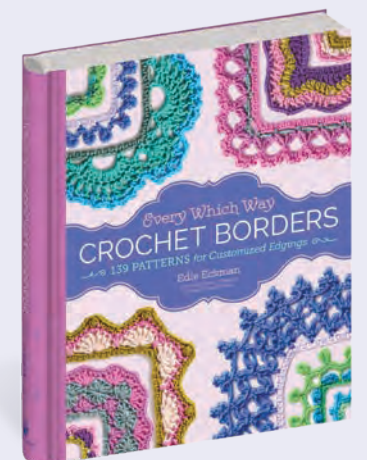

Every Which Way Crochet Borders

Step-by-step instructions and symbol charts make these 139 original designs accessible to all crocheters. In addition to plenty of practical design advice for those ready to chart their own course, each pattern is diagrammed to approach in rounds or rows, making this an inventive and invaluable resource for fiber enthusiasts.

■ **41,000 COPIES IN PRINT**

Hardcover with concealed wire-o;

224 pages; 7 x 9

Full-color

\$20.00 US

ISBN 978-1-61212-740-8



“Clearly written and comprehensive in scope, I wish I had had this book when I began to design.”

—Beth Brown-Reinsel, author of *Knitting Ganseys*

The Knitting Pattern Writing Handbook

KRISTINA MCGRATH, SARAH WALWORTH

An essential guidebook from two professional knitting tech editors that sets much-needed standards for writing clear, accurate instructions—perfect for those interested in writing and selling original patterns. Includes how to devise and present gauge, charts, and sizing information that is correct and easy-to-follow. With a focus on how to make patterns accessible to contemporary knitters—especially beginning knitters—this much-needed reference book is destined to become a classic.

Hardcover; 176 pages; 6 x 8
Full-color
\$20.00 US
ISBN 978-1-63586-624-7

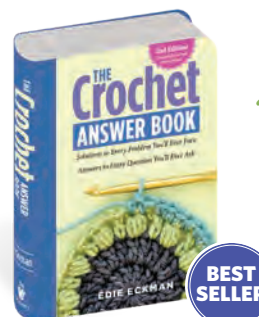

“A definitively revised guide that reflects the latest trends.”

—Booklist

BEST SELLER

The Crochet Answer Book, 2nd Edition

EDIE ECKMAN

Hundreds of crochet conundrums are solved in a friendly Q&A format. Eckman delivers straightforward guidance with plenty of encouragement from beginning basics like yarn styles, stitch types, and necessary tools to detailed outlines of more advanced techniques. There's information for every skill level, including illustrations for left-handed crocheters and tips for broomstick lace, linked stitches, and crochet cables. *The Crochet Answer Book* is full of expert advice on every page.

Flexibind with cloth spine; 408 pages;
4½ x 6½
Two-color
\$16.99 US
ISBN 978-1-61212-406-3

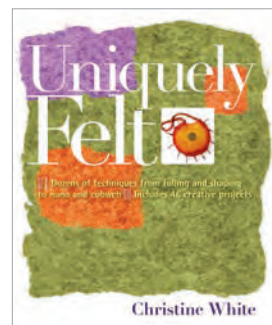

Uniquely Felt

CHRISTINE WHITE

Suitable for all skill levels, this is the essential resource on feltmaking—a complete primer on felting equipment and techniques, including traditional, needle, and nuno, with step-by-step instructions for 46 projects and profiles of professional feltmakers.

■ **42,000 COPIES IN PRINT**

Paper; 320 pages; 8¼ x 10
Full-color
\$24.95 US
ISBN 978-1-58017-673-6

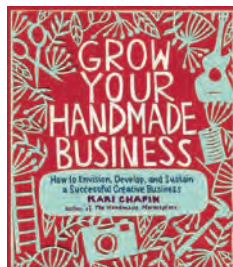

Grow Your Handmade Business

KARI CHAPIN

With supportive “you-can-do-it” coaching, this book covers all of the issues involved in turning a creative hobby into a successful business. Sprinkled throughout are words of wisdom from business-savvy creatives who share their advice on how to achieve profitability.

Paper; 272 pages; 6½ x 7½
Two-color
\$16.95 US
ISBN 978-1-60342-989-4



The Handmade Marketplace, 2nd Edition

KARI CHAPIN

This completely updated second edition of the best-selling crash course in DIY entrepreneurship includes online resources, such as Pinterest and Instagram, and addresses recent trends in craft marketing. It features wisdom and insider advice from a collection of successful crafters and artists.

Paper; 256 pages; 6½ x 7½
Two-color
\$16.95 US
ISBN 978-1-61212-335-6



Hand Dyeing Yarn and Fleece

GAIL CALLAHAN

With just some yarn, dye, and heat, fiber enthusiasts can satisfy every color craving without leaving their home kitchens. This accessible reference includes advice on color theory and types of dyes, as well as eight projects using colorful yarns.

■ **43,000 COPIES IN PRINT**

Hardcover with concealed wire-; 168 pages; 7 x 9
Full-color
\$20.00 US
ISBN 978-1-60342-468-4



The Weaving Explorer

DEBORAH JARCHOW & GWEN W. STEEGE

This collection introduces an unexpected range of materials and methods for making beautiful, functional creations with a contemporary feel. Crafters and artists will discover an array of projects that are achievable with a simple home-made loom or no loom at all!

Hardcover; 320 pages; 8 x 10
Full-color
\$29.95 US
ISBN 978-1-63586-028-3



Inventive Weaving on a Little Loom

SYNE MITCHELL

This complete guide to rigid-heddle looms explores their full potential with a surprisingly broad array of techniques and projects. Step-by-step photography leads readers through the warping and setup process. Projects range from pillows and curtains to bags, shawls, and even jewelry, showcasing a range of textural effects and materials, including silky threads, rayon chenille, and wire.

■ **54,000 COPIES IN PRINT**

Paper; 296 pages; 8¼ x 10
Full-color
\$29.99 US
ISBN 978-1-60342-972-6

BEST SELLER



How to Crochet

SARA DELANEY

From choosing yarn and working single chain to swatching for gauge and reading patterns, beginner crocheters will find success from the start with the expert instructions in this introductory guide to crochet fundamentals.

Paper; 128 pages; 5 x 7
Illustrations throughout
\$9.99 US
ISBN 978-1-61212-392-9

Storey BASICS®



How to Spin

BETH SMITH

Spinning yarn from raw fiber is gaining followers, especially among knitters. This book offers a succinct introduction for anyone new to the craft, beginning with selecting a spinning wheel and guiding readers through every stage of preparing the fiber, plying, winding off, and finishing.

Paper; 128 pages; 5 x 7
Illustrations throughout
\$9.95 US
ISBN 978-1-61212-612-8

Storey BASICS®



The Spinner's Book of Fleece

BETH SMITH

Demonstrated here are specific methods for working with fiber from 21 different breeds to achieve the best results, no matter what the project. Each chapter covers a group of sheep with similar characteristics: fine wool, longwool, down, and multicoat. Profiles include photos of the sheep and its locks, as well as a brief history of the breed.

Hardcover; 256 pages; 8 x 9
Full-color
\$32.00 US
ISBN 978-1-61212-039-3



The Field Guide to Fleece

DEBORAH ROBSON & CAROL EKARIUS

This pocket-size reference covers 100 sheep breeds, the characteristics of their fleece, and the kinds of projects for which their fleece is most suited. Each breed profile includes a photograph of the animal and details about its origin and conservation status, as well as the weight, staple length, fiber diameter, and natural colors of its fleece.

Paper; 232 pages; 5 x 7
Full-color
\$14.99 US
ISBN 978-1-61212-178-9



Yarnitecture

JILLIAN MORENO

This beautiful volume leads knitters through every phase of yarn construction, with step-by-step photos showing how to select the fiber, establish a foundation, and achieve the desired structure, texture, and color patterning. In addition, 12 original patterns from leading knitwear designers showcase handspun yarn.

Hardcover; 240 pages; 8¼ x 10
Full-color
\$32.00 US
ISBN 978-1-61212-521-3

BEST SELLER



The Spinner's Book of Yarn Designs

SARAH ANDERSON

Lush photographs illustrate the process of turning fleece into yarn, reveal the unique architecture of 80 distinctive yarns, and show exactly how to manipulate and combine fibers to get the desired results. A must-have reference for every spinner!

Hardcover with 32 technique cards in an envelope; 256 pages; 8 x 9
Full-color
\$29.95 US
ISBN 978-1-60342-738-8

“This is an excellent resource for fiber artists curious about different types of animal fibers and how best to use them.”

—Vogue Knitting

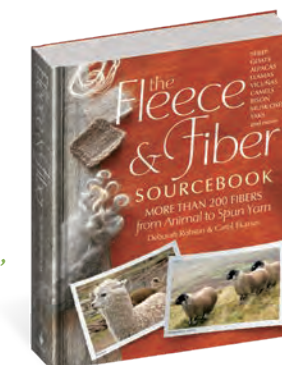

The Fleece & Fiber Sourcebook

DEBORAH ROBSON & CAROL EKARIUS

This one-of-a-kind encyclopedia shines a spotlight on more than 200 animals and their wondrous fleece. Profiling a worldwide array of fiber-producers that includes northern Africa's dromedary camel, the Navajo churro, and the Tasmanian merino, Carol Ekarius and Deborah Robson include photographs of each animal's fleece at every stage of the handcrafting process, from raw to cleaned, spun, and woven. The Fleece & Fiber Sourcebook is an artist's handbook, travel guide, and spinning enthusiast's ultimate reference source all in one.

■ **53,000 COPIES IN PRINT**

Hardcover with jacket; 448 pages;
8¼ x 10
Full-color
\$40.00 US
ISBN 978-1-60342-711-1

“It is rare that a book covers a subject with such depth as this one does.”

—Jane Patrick, creative director, Schacht Spindle Company

The Art of Tapestry Weaving

REBECCA MEZOFF

Tapestry weaving has a whole new look, and fiber enthusiasts of all levels are eager to try their hand at creating images with yarn. Rebecca Mezoff, a renowned teacher of contemporary tapestry weaving, shares her techniques in this in-depth guide to every aspect of the process, from developing a color palette to selecting yarn, warping the loom, and weaving the image. Detailed step-by-step photos and inspiring examples from a range of weaver-artists make this a one-stop how-to resource.

Hardcover; 320 pages; 8¼ x 10
Full-color
\$35.00 US
ISBN 978-1-63586-135-8

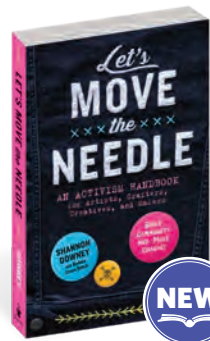

“Much more than a craft book ... Shannon’s warmth and wit shine through as she challenges you to step out of your comfort zone and start crafting for the greater good.”

—Stephanie Rohr, author of *Feminist Cross-Stitch*

Let's Move the Needle

SHANNON DOWNEY
Shannon Downey, an outspoken voice in the craftivist movement for over a decade, provides a roadmap and accessible toolkit for burgeoning art activists. Filled with self-reflective activities, exercises, prompts, and stories, *Let's Move the Needle* educates and empowers creatives to center their art around collective action in service of political, social or community issues they are most passionate about; affirming that everyone can be a changemaker and that change-making can be generative, enjoyable, and a bit sassy!

Paper; 264 pages; 5½ x 8½
Full-color
\$19.99 US
ISBN 978-1-63586-890-6



“Accessible skill-building over a range of needle-crafts—and the delight with which the authors encourage readers to upcycle, improvise, and break the rules is utterly contagious.”

—Margaret Bloom, author of *Making Peg Dolls and More*

Stitch Camp

NICOLE BLUM & CATHERINE NEWMAN
Authors Nicole Blum and Catherine Newman get kids ages 9-14 started with complete instructions for mastering six favorite fiber crafts. Step-by-step photos teach the basics of how to sew, knit, crochet, felt, embroider, and weave, plus how to make three projects for each craft. From woven patches and a knitted backpack to embroidered merit badges and a crocheted bracelet, the fresh projects encourage creative variations and build confidence along with valuable life skills.

■ For ages 9-14
Paper with flaps and 2 sheets of punch-out gift tags; 208 pages; 8 x 10
Full-color
\$19.99 US
ISBN 978-1-61212-750-7



All Points Patchwork

DIANE GILLELAND
This is a complete course in English paper piecing techniques: cut the desired shapes from paper, baste the paper to the back of the fabric, then hand-sew the pieces together. This ingenious method ensures perfectly matched points every time. Step-by-step photos illustrate how to connect triangles, octagons, diamonds, and other shapes.

Paper; 224 pages; 9 x 9½
Full-color
\$19.99 US
ISBN 978-1-61212-420-9



How to Make a Quilt

BARBARA WEILAND TALBERT
With basic sewing skills and step-by-step instructions, any sewer can make a patchwork quilt. The complete process is outlined, from selecting a design and fabric to cutting pieces, assembling blocks and the quilt top, and finishing.

Paper; 128 pages; 5 x 7
Illustrations throughout
\$9.95 US
ISBN 978-1-61212-408-7

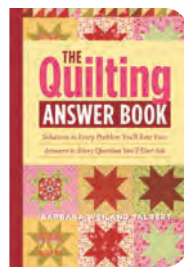

The Quilting Answer Book

BARBARA WEILAND TALBERT
This handy pocket reference solves more than 275 quilting quandaries related to cutting, piecing, appliqué, borders, binding, and more. Readers also get helpful advice on materials, equipment, and storage.

■ **76,000 COPIES IN PRINT**
Flexibind with paper spine; 432 pages; 4½ x 6½
Two-color
\$16.99 US
ISBN 978-1-60342-144-7



Wonder Walls

ROXY PRIMA & PHOEBE CORNOG
This colorful book features DIY how-to wall painting techniques that will help readers discover the possibilities of paint and see their walls as their canvas. With easy step-by-step instructions, the book includes tips for wall preparation and paint selection along with techniques from gradient blending and sponging to geometric design, lettering, and more.

Paper; 204 pages; 9 x 9
Full-color
\$24.95 US
ISBN 978-1-63586-277-5



The Sandalmaking Workshop

RACHEL CORRY
Making shoes is a surprisingly accessible, with this photo-rich guide and just a few simple tools and materials, even a beginner can make a comfortable, modern, stylish pair of sandals in the course of a day. The book includes traceable patterns for 14 of author Rachel Corry's original designs—both open- and closed-toe styles, including mules and slides—and covers every step of the process.

Hardcover with three gatefolds; 208 pages; 8 x 10
Full-color
\$30.00 US
ISBN 978-1-63586-235-5



Spruce: A Step-by-Step Guide to Upholstery and Design

AMANDA BROWN
These 900 step-by-step photographs from projects in the author's own house illustrate the stunning effect upholstery can have on an interior space. Through the six featured projects, readers learn the skills to create one-of-a-kind pieces. There are also chapters on interior design principles and how to sew throw pillows to accent reupholstered furnishings.

Hardcover; 400 pages; 8 x 10
Full-color
\$35.00 US
ISBN 978-1-61212-137-6

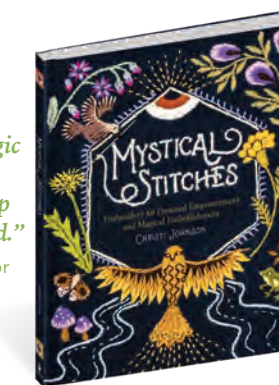

“The links between magic and creativity and spirituality are so deep and beautifully expressed.”

—Sarah K. Benning, author of *Embroidered Life*

Mystical Stitches

CHRISTI JOHNSON
Hand embroidery can be a joyous respite from busy daily life. *Mystical Stitches* combines this beloved and accessible craft with a spiritual element, introducing nearly 200 different symbols that readers can use or combine to create unique talismans infused with personal meaning. Along with basic techniques and an illustrated encyclopedia of stitches, a full-color treasury of Christi Johnson's patterns—inspired by botanicals, animals, the cosmos, earth elements, and more—will inspire crafters to create powerful, personalized designs they can stitch on clothes, hang on the wall, place on an altar, carry with them, or display in a place of prominence.

Hardcover; 208 pages; 8 x 10
Full-color
\$25.00 US
ISBN 978-1-63586-334-5



Quilting with a Modern Slant

RACHEL MAY
Modern quilting allows artists the freedom to play with traditions and take liberties with fabrics and patterns. This book is chock-full of ideas to inspire quilters of every level, offering a glimpse into more than 70 unique visions, with profiles of quilters and artists who have developed their own aesthetic.

Paper; 224 pages; 9 x 9½
Full-color
\$19.95 US
ISBN 978-1-61212-063-8



The Sewing Answer Book

BARBARA WEILAND TALBERT
Perfect for everyone from beginners to experienced sewers, this friendly, reassuring resource with its question-and-answer format is easy to use and offers information for both machine and hand sewing as well as tips on specific techniques.

Flexibind with cloth spine; 432 pages; 4½ x 6½
Two-color
\$14.95 US
ISBN 978-1-60342-543-8

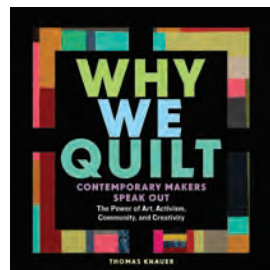

Why We Quilt

THOMAS KNAUER
Thomas Knauer blends bits of the craft's history with the stories and work of today's leading quilters, highlighting themes of tradition, community, consumerism, change, and creativity. With stunning photos of contemporary quilts, this book will enthrall all types of handcraft enthusiasts.

Hardcover; 224 pages; 8 x 8
Full-color
\$29.95 US
ISBN 978-1-63586-033-7

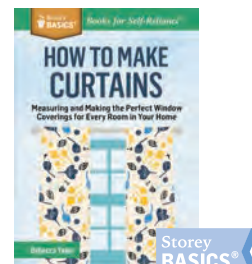

How to Make Curtains

REBECCA YAKER
This is a complete introduction to making curtains, from measuring to calculating yardage and selecting the appropriate fixtures and hardware for hanging. Included are step-by-step instructions for making five curtain styles.

Paper; 128 pages; 5 x 7
Illustrations throughout
\$8.95 US
ISBN 978-1-61212-539-8



How to Make Slipcovers

PATRICIA HOSKINS
Tired furniture gets a new lease on life with step-by-step instructions for making slipcovers. This book tackles everything from selecting fabric to perfecting curved seams, applying trims, and finishing with zippers, envelope backs, or ties.

Paper; 128 pages; 5 x 7
Illustrations throughout
\$8.95 US
ISBN 978-1-61212-525-1



Fabric-by-Fabric One-Yard Wonders

REBECCA YAKER & PATRICIA HOSKINS
From lightweight cottons to cozy flannels and durable coated fabrics, sewers will find the perfect pattern for every fabric in this collection of 101 projects, complete with illustrated instructions, cutting layouts, and pattern pieces.

■ **71,000 COPIES IN PRINT**
Hardcover with concealed wire-o and patterns; 416 pages; 8 x 8½
Full-color
\$29.95 US
ISBN 978-1-60342-586-5



“Talk about quality and quantity, *One Yard Wonders* is an impressive volume of super creative projects all utilizing our favorite scraps and a simple yard of fabric. This book is a keeper!”

—Library Journal

One-Yard Wonders

REBECCA YAKER & PATRICIA HOSKINS
Discover all that you can make with just one yard of fabric! Rebecca Yaker and Patricia Hoskins offer 101 stylish projects that use a single yard of fabric to make clothes, accessories, baby items, and more. With simple step-by-step instructions that are accompanied by templates and pattern pieces, each project is designed to be completed in just a few hours. Get inspired and turn a yard of your favorite fabric into a quilted lunch bag, bright sundress, or a cuddly plush turtle.

■ **230,000 COPIES IN PRINT**
Hardcover with concealed wire-o and patterns; 304 pages; 8 x 8½
Full-color
\$27.99 US
ISBN 978-1-60342-449-3

BEST-SELLING SERIES SEWING SCHOOL®



“Offers tempting projects that cover basic knowledge, like threading a needle, and then moves on to easy, fun projects, such as drawstring bags or a superhero cuff.”

—Booklist’s Top 10 Craft Books for Youth

Sewing School®

AMIE PETRONIS PLUMLEY & ANDRIA LISLE

This inspiring guide includes 21 fun sewing projects for children ages 5 and up. With easy-to-follow illustrated instructions and cut-out patterns, young crafters will quickly be sewing up colorful pillows, potholders, dolls, blankets, and more. These kid-tested projects require only minimal supervision, and most can be made using simple hand stitches, so no sewing machine is required. With plenty of encouragement and helpful tips, young sewers will develop their skills while sparking a passion that will last a lifetime.

- For ages 5–10
- **256,000 COPIES IN PRINT**

Paper with concealed wire-o and patterns; 144 pages; 9 x 9½
Full-color
\$18.95 US
ISBN 978-1-60342-578-0



Sewing School® 2

AMIE PETRONIS PLUMLEY & ANDRIA LISLE

Kid-friendly step-by-step text and photographs teach children the skills and techniques they need to master machine sewing. Reusable full-size pattern pieces are included in a bound-in envelope.

- For ages 8–12
- **72,000 COPIES IN PRINT**

Paper with concealed wire-o and patterns; 160 pages; 9 x 9½
Full-color
\$19.95 US
ISBN 978-1-61212-049-2



Sewing School® Quilts

AMIE PETRONIS PLUMLEY & ANDRIA LISLE

The creativity and timeless appeal of quilting reaches a new generation. Young sewists learn hand- and machine-sewing techniques and create projects both decorative and practical, including a patchwork pet bed, a crazy-quilt journal cover, and a recycled T-shirt quilt.

- For ages 8–12

Paper with concealed wire-o and patterns; 160 pages; 9 x 9½
Full-color
\$18.95 US
ISBN 978-1-61212-859-7



Sewing School® Fashion Design

AMIE PETRONIS PLUMLEY & ANDRIA LISLE

This comprehensive kids’ course comes with clothing patterns for sizes XS–XL. Step-by-step photos and actual kid-created examples teach young sewers the fundamentals of making three basic garments—a top, a pair of shorts, and a skirt.

- For ages 8–12

Paper with concealed wire-o and patterns; 160 pages; 9 x 9½
Full-color
\$22.95 US
ISBN 978-1-61212-860-3



Includes fabric labels

Sewing School® Box Set

AMIE PETRONIS PLUMLEY & ANDRIA LISLE

This special box set features the bestsellers *Sewing School®* and *Sewing School® 2*, plus bonus “Made By” iron-on fabric labels for personalizing kids’ creations.

- For ages 8–12

Two paperbacks with concealed wire-o and a set of iron-on fabric labels in a slipcase, shrink-wrapped; 304 pages; Full-color
\$40.00 US
ISBN 978-1-63586-117-4



Color-Your-Own Greeting Cards

CAITLIN KEEGAN

These 30 ready-to-color cards and envelopes have images and hand-lettered messages for celebrations throughout the year—including birthdays, weddings, anniversaries, new baby, and congratulations and thanks—as well as more general all-purpose pictures.

Paper; 30 pages; 5½ x 7½
Illustrations throughout
\$17.99 US
ISBN 978-1-61212-885-6

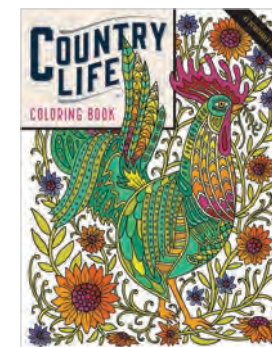

Country Life Coloring Book

CAITLIN KEEGAN

These 45 ready-to-color pages include a mixture of intricately hand-lettered phrases and charming scenes of farm life and outdoor beauty—including chickens, honey bees on flowers, and barns.

Paper; 90 pages; 8½ x 11
Illustrations throughout
\$12.95 US
ISBN 978-1-61212-884-9



“If Marie Kondo inspired you to change the way you fold T-shirts, then artist Megumi Lorna Inouye’s guide to creating beautiful gift-wrapping is for you.”

—BookPage, starred review

The Soul of Gift Wrapping

MEGUMI LORNA INOUE

With a combination of inventive wrapping designs, inspiring personal essays, and step-by-step techniques, Megumi Inouye invites readers to transform the act of wrapping into a gratitude practice. Drawing on the gift-giving traditions of her Japanese heritage, Inouye explores how the act of giving a thoughtfully wrapped gift can be a creative, caring act for both the giver and the receiver. Detailed photos teach Inouye’s artful approach to every aspect of wrapping—including tape-free folding, paper and fabric bows, message tags, and approaches for odd-shaped items.

Hardcover; 208 pages; 6 x 8
Full-color
\$25.00 US
ISBN 978-1-63586-554-7



“Summer art camps, art clubs, and after-school groups will find the creative projects in this enticing and beautiful book easy to understand, prepare for, and implement.”

—Cathy Topal, author of *Thinking with a Line*

Art Sparks

MARION ABRAMS & HILARY EMERSON LAY

Every kid can be an artist when they crack open this rich collection of 53 inspiring art projects curated by two art educators with decades of experience. Working with basic art supplies—from paint, markers, paper, and glue to household finds like cardboard boxes and fabric scraps—children learn that as long as they can imagine it, they can create it!

- For ages 9–14

Paper; 176 pages; 8 x 10
Full-color
\$16.95 US
ISBN 978-1-63586-118-1



Journal Sparks

EMILY K. NEUBURGER

These 60 interactive prompts, activities, and art how-tos provide endless inspiration for filling the blank page in fresh, inviting ways.

- For ages 10–100
- Gold Mom’s Choice Award
- Teachers’ Choice Award for the Classroom
- Dr. Toy Award
- National Parenting Product Award
- Gold Foreword INDIES Award
- **45,000 COPIES IN PRINT**

Paper; 164 pages; includes 2 sticker sheets, 3 sheets of paper punch-outs, and 10 sheets of decorative collage paper; 7½ x 9½
Full-color
\$18.99 US
ISBN 978-1-61212-652-4

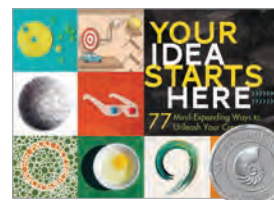

Your Idea Starts Here

CAROLYN ECKERT

This cleverly illustrated guide shows that creativity is a learnable skill and inspires everyone to try, with original graphics and simple text prompts that offer quick, outside-the-box approaches to cultivating innovative thinking and creative problem solving.

- Silver Nautilus Award

Hardcover; 224 pages; 7 x 5
Full-color
\$14.95 US
ISBN 978-1-61212-779-8



Make Your own Board Game

JESSE TERRANCE DANIELS

Jesse Terrance Daniels reveals exactly what makes a successful game and teaches how to create an original, customized tabletop game. Daniels leads readers through the design process, including how to develop a unique theme and select components. Includes four original sample games, four fold-out game boards, and a set of reproducible components, complete this in-depth guide.

Paper with 4 fold-out game boards; 144 pages; 8 x 10
Illustrations throughout
\$18.95 US
ISBN 978-1-63586-341-3

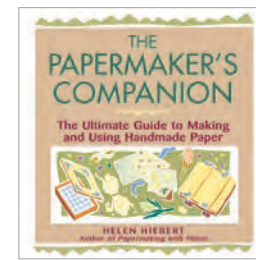

The Papermaker's Companion

HELEN HIEBERT

Clear, easy-to-follow instructions and step-by-step illustrations make this the ultimate guide to making paper with a variety of easy-to-obtain materials—from harvested plants to junk mail—and then using it creatively to craft lanterns, decorative boxes, and much more.

Paper; 224 pages; 8 x 8
Illustrations throughout
\$19.99 US
ISBN 978-1-58017-200-4



Papermaking with Garden Plants & Common Weeds

HELEN HIEBERT

With these illustrated, step-by-step instructions, readers can make exquisite decorative papers in their home kitchens from the fibers of weeds and common backyard plants like birch, cattail, daffodil, hollyhock, and milkweed. Additional directions show how to use the handcrafted papers to create one-of-a-kind envelopes, lampshades, specialty books, and more.

Paper with flaps; 112 pages; 9¼ x 10
Full-color
\$19.99 US
ISBN 978-1-58017-622-4



Collage Your Life

MELANIE MOWINSKI

Artist and teacher Melanie Mowinski teaches a variety of core techniques including lettering, stamping, stenciling, transfers, and adhesive methods, and provides dozens of prompts to jumpstart the creative process and encourage crafters to explore the versatility of collage.

Paper; 224 pages; 8¼ x 10
Full-color
\$22.95 US
ISBN 978-1-63586-356-7

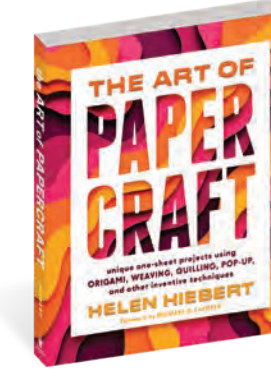

“You’ll want to sit down and start making right away!”

—Ann Martin, quilling artist and author of *All Things Paper*

The Art of Paper Craft

HELEN HIEBERT

Paper artist and teacher Helen Hiebert compiles a one-of-kind collection of 40 unique projects, each using just one sheet of paper. Combining decorative paper techniques like marbling, stamping, and stenciling with dimensional techniques like origami, cutting, folding, quilling, stretching, weaving, and pop-ups, *The Art of Papercraft* offers a rich variety of projects that will delight crafters, artists, and designers alike, including paper votive lights, pop-up cards, folded paper gift boxes and envelopes, woven paper wall hangings, miniature one-sheet books, and much more.

Paper; 320 pages; 8 x 10
Full-color
\$24.95 US
ISBN 978-1-63586-265-2

BEST-SELLING AUTHOR ANNE-MARIE FAIOLA



“An indispensable reference for every natural artisan soapmaker, with some of the most innovative recipes I’ve ever seen! Be prepared to get inspired.”

—Britanie Faith, influencer and founder of *Beauty by Britanie*

Milk Soaps

For beginners and experts alike, this focused guide to making soaps enriched with animal and plant milks takes soapmaking skills in new and exciting directions. Expert soapmaker Anne-Marie Faiola illuminates the process for creating milk-based soaps with step-by-step techniques and 35 recipes for bars that are beautiful to look at and beneficial for the skin.

Hardcover with concealed wire-o; 272 pages; 7 x 9
Full-color
\$21.95 US
ISBN 978-1-63586-048-1



Pure Soapmaking

These 32 original recipes for cold-process soaps, scented with all-natural essential oils, feature a surprising range of organic ingredients. Step-by-step photography guides the reader through creating different soap styles, from simple castile bars to disks and bricks with swirls, embeds, and layers.

■ **104,000 COPIES IN PRINT**
Hardcover with concealed wire-o; 240 pages; 7 x 9
Full-color
\$22.00 US
ISBN 978-1-61212-533-6



Soap Crafting

Making soap is easy with these 31 recipes, full-color photographs, and step-by-step instructions. With chapters on using unusual colors, molds, and molding techniques, this is the one-stop resource for soapmakers of any skill level.

■ **55,000 COPIES IN PRINT**
Hardcover with concealed wire-o; 240 pages; 7 x 9
Full-color
\$22.00 US
ISBN 978-1-61212-089-8



The Lavender Companion

TERRY BARLIN VESCI & JESSICA DUNHAM

This lavishly photographed celebration of the beloved herb, written by an acclaimed lavender farmer and cooking instructor, is brimming with ideas for bringing lavender into daily life. More than 40 recipes showcase lavender in delicious dishes as well as homemade craft and body products.

Hardcover; 176 pages; 7 x 9
Full-color
\$26.00 US
ISBN 978-1-63586-684-1



Herbal Activities for Kids

MOLLY MEEHAN BROWN

A compendium of crafts, cooking, gardening, and nature exploration activities introduces kids ages 7 and up to the versatility and creative fun of working and playing with herbs. With bits of lore about herbs sprinkled throughout, this is the perfect introduction to the versatility of herbs.

Paper; 112 pages; 8½ x 10½
Full-color
\$18.99 US
ISBN 978-1-63586-584-4

“Trawn and Roxas are putting the ‘fun’ in fungus.”

—Frank Hyman, author of *How to Forage Mushrooms Without Dying*

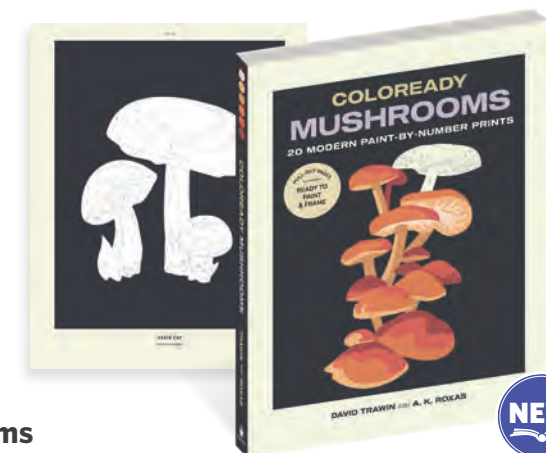

Coloready Mushrooms

DAVID TRAWIN & A.K. ROXAS

A fresh, modern take on paint-by-number features 20 frame-worthy mushroom images, accompanied by step-by-step instructions and humorous profiles of each mushroom. This book is an open invitation to create art. Inside you’ll find tips and techniques for painting 20 mushrooms printed on premium cardstock along with a swatch palette for color matching. The 8” x 10” sheets have two background options—light or dark—and are designed to fit store bought, ready-made frames.

Paper; 112 pages; 8 x 10
Full-color
\$24.99 US
ISBN 978-1-63586-875-3

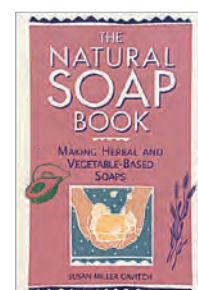

The Natural Soap Book

SUSAN MILLER CAVITCH

This book takes the mystery out of soapmaking with illustrations and clear directions for creating high-quality vegetable-based soaps that are good for the skin and free of synthetic additives.

■ **180,000 COPIES IN PRINT**
Paper; 192 pages; 6 x 9
Two-color
\$14.99 US
ISBN 978-0-88266-888-8

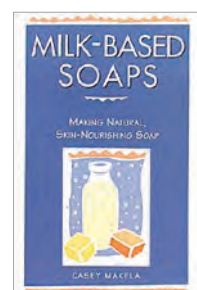

Milk-Based Soaps

CASEY MAKELA

It’s easy to blend moisturizing, skin-nourishing, milk-based soaps using these specialized yet simple techniques. Recipes for soaps, baths, and creams use common ingredients and equipment.

■ **38,000 COPIES IN PRINT**
Paper; 112 pages; 6 x 9
Two-color
\$12.95 US
ISBN 978-0-88266-984-7



Making Natural Liquid Soaps

CATHERINE FAILOR

All-natural, inexpensive hand soaps, shampoos, shower gels, bubble baths, and much more can be created using a simple double-boiler technique. Readers learn to blend oils, additives, color, and scent to develop one-of-a-kind liquid soaps.

■ **77,000 COPIES IN PRINT**
Paper; 144 pages; 7 x 10
Full-color
\$16.95 US
ISBN 978-1-58017-243-1



Making Transparent Soap

CATHERINE FAILOR

With common ingredients and easy-to-follow, step-by-step directions, crafters can produce transparent soaps that are milder, richer, and creamier than any commercial soap on the market.

Paper; 144 pages; 7 x 10
Full-color
\$16.95 US
ISBN 978-1-58017-244-8

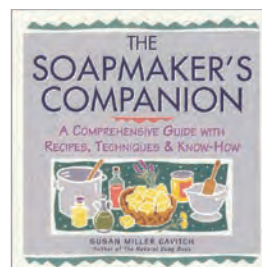

The Soapmaker's Companion

SUSAN MILLER CAVITCH

Readers learn every step of the soapmaking process—from basic skills to special techniques for marbling and stained glass effects—with these clear, easy-to-follow instructions. Detailed recipes for 40 specialty soaps will get readers crafting exotic and practical soaps in no time.

■ **160,000 COPIES IN PRINT**
Paper; 288 pages; 8 x 8
Two-color
\$21.99 US
ISBN 978-0-88266-965-6



Beaded Jewelry: Knotting Techniques

CARSON EDDY, RACHAEL EVANS & KATE FELD

Working with pearls, gemstones, and other precious beads requires mastering the classic method of knotting between each bead. This illustrated guide leads crafters step-by-step through every aspect of the technique.

Paper; 88 pages; 5 x 7
Illustrations throughout
\$8.95 US
ISBN 978-1-61212-486-5

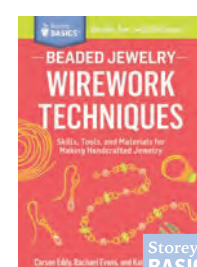

Beaded Jewelry: Wirework Techniques

CARSON EDDY, RACHAEL EVANS & KATE FELD

This highly illustrated, step-by-step guide demystifies the tools and techniques needed for crafting handmade beaded jewelry with wire. Crafters will learn how to select the right size wire for any project and how to bend it to create hanging earrings or beaded necklaces.

Paper; 88 pages; 5 x 7
Illustrations throughout
\$8.95 US
ISBN 978-1-61212-484-1



Beaded Jewelry: Stringing Techniques

CARSON EDDY, RACHAEL EVANS & KATE FELD

From choosing the right string for a project to finishing options with clasps and hooks, this guide introduces crafters to the tools and techniques needed to make beautiful beaded necklaces and bracelets with clear instructions and helpful illustrations.

Paper; 88 pages; 5 x 7
Illustrations throughout
\$8.95 US
ISBN 978-1-61212-482-7



The Beading Answer Book

KAREN MORRIS

Here are solutions to beading problems big and small, from organizing tips to stringing techniques, weaving with beads, and repairs. This indispensable reference is filled with illustrated instructions and insightful advice to help every beader solve the most vexing dilemmas.

Flexibind with cloth spine; 432 pages; 4½ x 6½
Two-color
\$14.95 US
ISBN 978-1-60342-034-1



The Candlemaker's Companion

BETTY OPPENHEIMER

The illustrated, step-by-step instructions and detailed source list will inspire and instruct crafters of all skill levels on how to roll, pour, dip, and mold candles for every occasion.

Paper; 208 pages; 8 x 8
Illustrations throughout
\$19.95 US
ISBN 978-1-58017-366-7



“Filled with beautiful photos and packed with practical diagrams, this extensively researched reference is essential for any horse-lover’s library.”

—Allan J. Hamilton, author, *Zen Mind, Zen Horse*



Grab the Reins with This Definitive Reference to All Things Equine.



Horses bring out the best in us. No matter what the rest of our lives are like, with horses we learn to be sensitive, courageous, responsible, and honest.

The Horse-Lover's Encyclopedia, 2nd Edition

EDITED BY JESSIE HAAS

Bridging gaps in the equestrian universe between English and Western styles, this completely revised second edition features more than 1,700 entries on wide-ranging topics such as breeds, tack, facilities, equine care and management, health and safety issues, riding styles and disciplines, shows, and much more.

Paper; 432 pages; 8½ x 10½
Full-color
\$29.95 US
ISBN 978-1-61212-678-4

Hardcover;
\$39.95 US
ISBN 978-1-61212-682-1

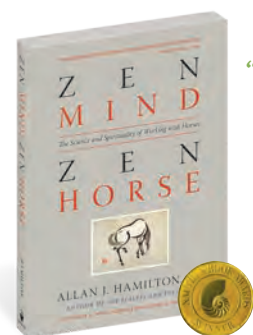

“Hamilton’s ideas will resonate with anyone who has ever formed a close relationship with a horse.”

—*Library Journal*

Zen Mind, Zen Horse

Eastern philosophy enters the stables in this unique guide to horsemanship. Allan Hamilton describes how horses understand and respond to the flow of vital energy around them. They use this energy, called chi, to communicate with their herd, express dominance, and sense predators. Hamilton shares safe, simple techniques to make you more receptive to your animal’s chi, so you can develop a calm and effective training style that will not only help your horse follow commands, but strengthen the spiritual bond between horse and rider.

■ Gold Nautilus Award

Paper; 320 pages; 7 x 10
Full-color
\$26.99 US
ISBN 978-1-60342-565-0

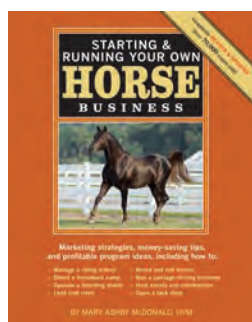

Starting & Running Your Own Horse Business, 2nd Edition

MARY ASHBY McDONALD, DVM

This handbook for launching a successful horse business, whether a riding school or a tack shop, guides readers through the ins and outs of business plans, marketing, safety issues, insurance, taxes, legal considerations, good horse management, and veterinary costs.

Paper; 224 pages; 8½ x 10½
Illustrations throughout
\$19.95 US
ISBN 978-1-60342-483-7

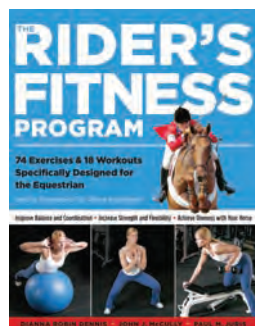

The Rider's Fitness Program

DIANNA ROBIN DENNIS, JOHN J. McCULLY & PAUL M. JURIS

More than 85 exercises, illustrated with step-by-step instructional photography, improve balance, flexibility, and coordination. New and experienced riders will gain strength, resulting in fewer aches and pains.

■ **41,000 COPIES IN PRINT**
Paper; 224 pages; 8½ x 10½
Photographs and illustrations throughout
\$22.99 US
ISBN 978-1-58017-542-5

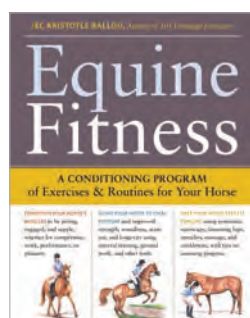

Equine Fitness

JEC ARISTOTLE BALLOU

These 50 conditioning exercises are designed to enhance a horse’s soundness, stamina, quality of motion, longevity, strength, and agility, with variations for horses of different ages and abilities. Individual and group exercise routines are described in detail, then condensed onto pull-out cards to which riders can refer throughout the exercise.

Paper; 168 (144 standard + 24 card stock) pages; 8½ x 10½
Illustrations throughout
\$22.99 US
ISBN 978-1-60342-463-9

BEST-SELLING AUTHOR CHERRY HILL



“Will intrigue anyone seeking to enrich and strengthen the horse-human relationship.”

—*Northwest Rider*



What Every Horse Should Know

Every horse needs a basic education to live among humans safely and confidently. Readers will come to understand how horses learn, how to handle a horse without fear, how to teach respect and patience, and how to help the horse master the actual “work” it needs to do.

Paper; 192 pages; 7½ x 10
Full-color
\$19.95 US
ISBN 978-1-60342-713-5

“An excellent look at an extraordinary animal.”

—*Bristol Herald Courier*

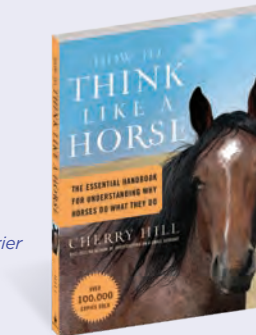

How to Think Like a Horse

Here is a unique in-depth discussion of how horses think, learn, respond to stimuli, and interpret human behavior. By understanding what causes a horse to feel happy or distressed, and by communicating with a horse in language it can understand, a human can make training much easier and more rewarding.

■ **258,000 COPIES IN PRINT**

Paper; 192 pages; 7½ x 10
Full-color
\$19.95 US
ISBN 978-1-58017-835-8



Horse Health Care

Packed with useful advice on mastering dozens of essential health-care skills and illustrated with step-by-step photographs, this volume covers wound care, leg wrapping, injections, dental exams, basic restraint, and more.

■ **66,000 COPIES IN PRINT**
Paper; 160 pages; 8½ x 10½
Photographs and illustrations throughout
\$19.95 US
ISBN 978-0-88266-955-7



Stablekeeping

From design to management to maintenance, good stablekeeping minimizes repair expenses, reduces feed and veterinary bills, keeps horses safe and content, and provides a pleasant workplace for owners and riders.

■ **40,000 COPIES IN PRINT**
Paper; 160 pages; 8½ x 10½
Photographs and illustrations throughout
\$19.99 US
ISBN 978-1-58017-175-5

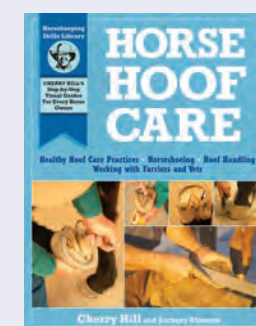

Horse Hoof Care

Good hoof care is key to every horse’s health and performance. This complete guide explains hoof anatomy, the farrier’s role, and the importance of daily routines and consistent care. If it affects horse foot health, it’s explained in this book.

Paper; 160 pages; 8½ x 10½
Photographs and illustrations throughout
\$19.99 US
ISBN 978-1-60342-088-4

“...a wealth of information for first-time horse owners as well as for more experienced horseman. In fact, about the only thing Hill hasn’t done is choose a horse for the reader.”

—*Paint Horse Journal*



Horsekeeping on a Small Acreage

Keeping your own horses requires dedication, hard work, and a sincere interest in the well-being of your animals. This practical guide shows you how to design efficient facilities and establish effective maintenance routines so that your horses can stay happy, healthy, and safe on even the smallest plots of land. Offering expert advice on barn designs, fencing options, and pasture management, Cherry Hill stresses the importance of understanding horse behavior and environmentally responsible land stewardship as integral aspects of a pleasurable and rewarding horsekeeping experience.

Paper; 320 pages; 8½ x 10½
Full-color
\$26.95 US
ISBN 978-1-58017-535-7

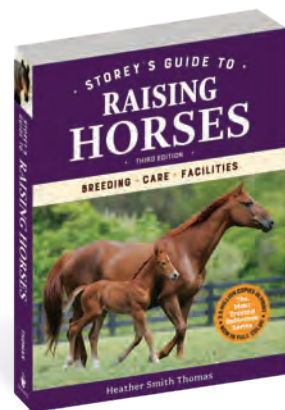

Storey's Guide to Raising Horses, 3rd Edition

HEATHER SMITH THOMAS

For everyone from experienced handlers to first-time buyers, this complete guide to horse raising covers all aspects of keeping a horse fit and healthy. Best-selling author Heather Smith Thomas provides calm, clear advice on safe fencing and paddock options, disease prevention and vaccination, hoof care, foaling and weaning, and even greener horsekeeping and pasturing methods.

Paper; 448 pages; 7 x 9 1/2
Full-color
\$26.95 US
ISBN 978-1-63586-085-6

Hardcover;
\$36.95 US
ISBN 978-1-63586-086-3

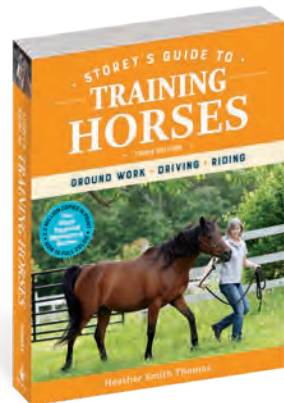

Storey's Guide to Training Horses, 3rd Edition

HEATHER SMITH THOMAS

This fully updated reference features a complete program for turning a shy, gangly foal into a calm, coordinated, and skillful equine partner, with a thorough grounding in both Western and English saddle work, driving, trailer training, and more.

Paper; 448 pages; 7 x 9 1/2
Full-color
\$24.95 US
ISBN 978-1-63586-120-4
Hardcover;
\$34.95 US
ISBN 978-1-63586-121-1



Knowing Horses

LES SELLNOW & CAROL A. BUTLER

New and experienced horse lovers alike will get to know their companions better with this companionable compendium of all things equine. It answers hundreds of questions about behavior, physiology, breed characteristics, training, sporting events, and the long-standing relationship between humans and horses.

Paper; 256 pages; 5 1/2 x 8
Two-color
\$16.99 US
ISBN 978-1-60342-798-2



Easy-Gaited Horses

LEE ZIEGLER

A horse that is calm, obedient, relaxed, and sure-footed is a pleasure to ride. With this comprehensive guide, riders will learn humane methods for training a variety of horses to specific gait, with emphasis on equine anatomy and good horsemanship.

Paper; 256 pages; 8 1/2 x 10 1/2
Illustrations throughout
\$19.95 US
ISBN 978-1-58017-562-3

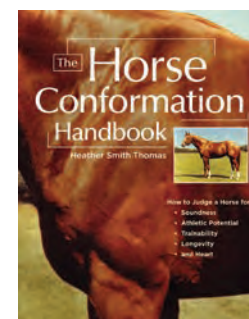

The Horse Conformation Handbook

HEATHER SMITH THOMAS

This comprehensive volume examines the critical components of horse evaluation—including body proportion and balance, body and leg angles, and height—and discusses how variations will affect a horse's performance and suitability for particular functions.

44,000 COPIES IN PRINT
Paper; 400 pages; 8 1/2 x 10 1/2
Illustrations throughout
\$27.95 US
ISBN 978-1-58017-558-6

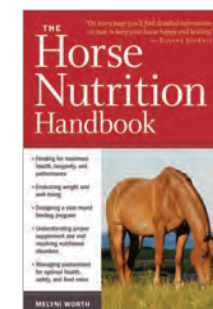

The Horse Nutrition Handbook

MELYNI WORTH

A balanced, nutritious diet is key to horse well-being. This handbook covers every element of horse nutrition, including the specific needs of brood mares, performance horses, and other working animals; the benefits of additives and herbal supplements; and dietary solutions to common health problems.

Paper; 256 pages; 6 x 9
Photographs and illustrations throughout
\$19.99 US
ISBN 978-1-60342-541-4

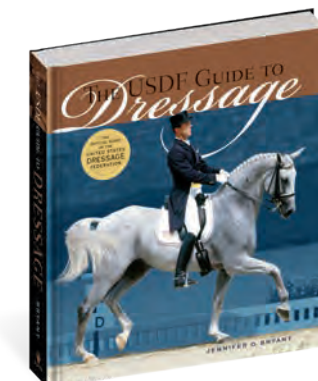

"This fantastic guide will be a treasured work for students of dressage."

—The American Quarter Horse

The USDF Guide to Dressage

JENNIFER O. BRYANT

Easy-to-follow photographic sequences demystify basic dressage techniques for riders of all disciplines. This thorough handbook also covers the history of dressage, terms and equipment, management of the dressage horse, and much more.

Hardcover with jacket; 352 pages; 9 x 10
Full-color
\$39.95 US
ISBN 978-1-58017-529-6

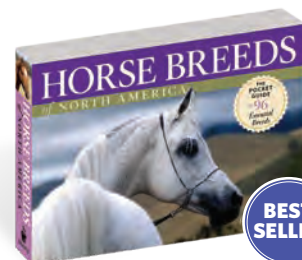

"If you're a horse lover, you'll want a copy of this little gem on your bookshelf."

—Washington Post

Horse Breeds of North America

JUDITH DUTSON

Collected in a perfect little pocket guide no horse lover will be able to resist, here are images of 96 breeds that call North America home. For each breed readers will find a full-page photograph accompanied by at-a-glance conformation and historical facts. A small map shows where the breed originated, and additional information includes the horse's special qualities and its most common uses.

126,000 COPIES IN PRINT

Paper; 208 pages; 6 x 4 1/4
Full-color
\$12.99 US
ISBN 978-1-58017-650-7



The Horse Training Problem Solver

JESSICA JAHIEL

Training a horse brings an array of vexing challenges. In an accessible Q&A format, this book offers sensible answers to common training problems. The combination of basic theory, effective solutions, and handy tips and strategies will ensure a more satisfying experience for both horse and rider.

Paper; 416 pages; 6 x 9
Illustrations throughout
\$19.95 US
ISBN 978-1-58017-686-6

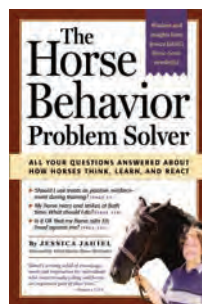

The Horse Behavior Problem Solver

JESSICA JAHIEL

Through a friendly Q&A format, readers will come to understand how a horse thinks and learns, why it acts the way it does, and how one should respond. Real-life case studies provide workable answers to common problems.

73,000 COPIES IN PRINT

Paper; 352 pages; 6 x 9
Illustrations throughout
\$19.95 US
ISBN 978-1-58017-524-1



Among Wild Horses

LYNNE POMERANZ

In this gorgeous photographic journal, photographer Lynne Pomeranz documents two years in the lives of the Pryor Mountain Mustangs of the American West, capturing the enduring courage, resilience, and freedom of these wild descendants of equine royalty.

Hardcover with jacket;
144 pages; 9 x 6 1/4
Full-color
\$18.95 US
ISBN 978-1-58017-633-0

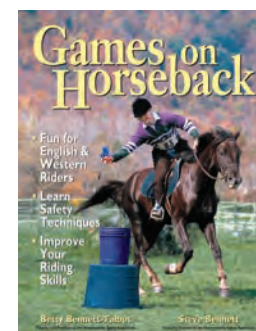

Games on Horseback

BETTY BENNETT-TALBOT & STEVE BENNETT

Riders of all levels will improve their equestrian skills and have fun with friends using this collection of more than 50 safe, exciting, and challenging games for horse and rider.

44,000 COPIES IN PRINT

Paper; 144 pages; 8 1/2 x 11
Full-color
\$19.95 US
ISBN 978-1-58017-134-2



The Foaling Primer

CYNTHIA McFARLAND

Chronicling the first year of a horse's life in amazing, up-close photographs, this introductory handbook guides the reader through this critical period. Detailed descriptions and instruction on birth, care, handling, training, and weaning, plus a month-by-month guide, offer everything needed to raise a healthy foal.

Paper; 160 pages; 8 x 10
Full-color
\$22.99 US
ISBN 978-1-58017-608-8



The Horse Doctor Is In

BRENT KELLEY, DVM

In a warm, conversational style, experienced veterinarian Brent Kelley writes about horse health care, using real-life stories from his 30 years of seeing equine patients to answer questions about everything from fertility to fractures to foot care.

Paper; 416 pages; 6 x 9
Illustrations throughout
\$19.99 US
ISBN 978-1-58017-460-2

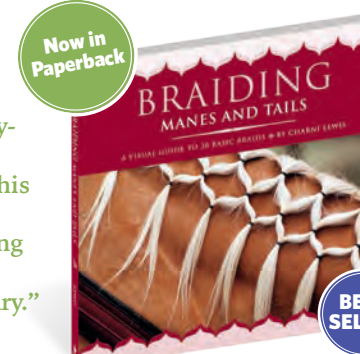

"Clear, step-by-step instructions make this sometimes overwhelming task seem a little less scary."

—Horsemen's Yankee Pedlar

Braiding Manes and Tails

CHARNI LEWIS

Next to riding, there is nothing horse people love more than pampering and grooming their horses, and braiding manes and tails is particularly enjoyable for horse and rider alike. Here are 30 mane and tail braids for every occasion—from casual rides to blue-ribbon events—described with step-by-step illustrations and color photographs.

Paper; 152 pages; 9 1/2 x 9
Full-color
\$16.95 US
ISBN 978-1-63586-309-3

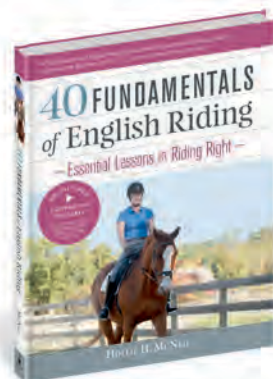

40 Fundamentals of English Riding

HOLLIE H. MCNEIL
Master the 40 basic elements essential to riders in dressage, jumping, and eventing. Each fundamental is defined and explained, with tips on proper technique and an emphasis on how to avoid common errors. Accompanying online videos serve as a helpful visual aid.

Hardcover; 192 pages; 8½ x 10½
Full-color
\$40.00 US
ISBN 978-1-60342-789-0

"McNeil's ... book brings us the top techniques that can help you reach your own riding goals by gaining a thorough understanding of the basics of classical riding."
—Horsemen's Yankee Pedlar

BEST-SELLING SERIES READ & RIDE

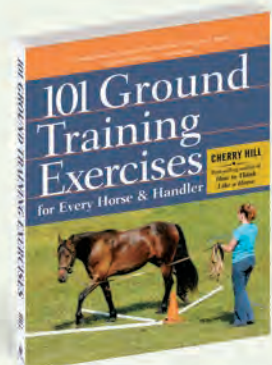

101 Ground Training Exercises for Every Horse & Handler

CHERRY HILL
Ground training is the key to safe, successful riding and creates a strong bond between horse and rider. These 101 exercises cover everything from haltering to driving and transitions.

41,000 COPIES IN PRINT
Paper; 256 pages; 8½ x 10½
Photographs and illustrations throughout
\$29.99 US
ISBN 978-1-61212-052-2

"Comprehensive and easy to follow."
—Equine Journal

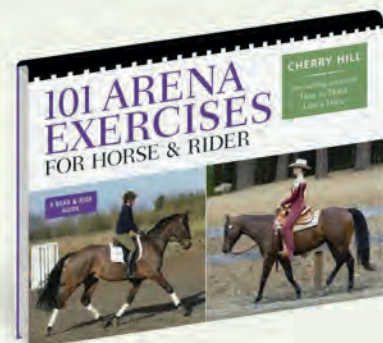

101 Arena Exercises for Horse & Rider

CHERRY HILL
This illustrated guide presents recognized classic exercises for both English and Western riders, plus original patterns and maneuvers useful for improving the skills of horses and riders alike.

174,000 COPIES IN PRINT
Paper with comb binding; 224 pages; 11 x 8½
Illustrations throughout
\$29.95 US
ISBN 978-0-88266-316-6

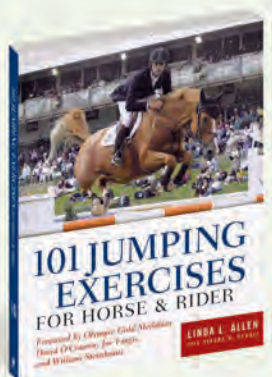

101 Jumping Exercises for Horse & Rider

LINDA L. ALLEN WITH DIANNA R. DENNIS
Here is a must-have workbook that provides a logical and consistent series of exercises with easy-to-follow maps and instructions for all riding abilities.

Paper; 240 pages; 8½ x 11
Illustrations throughout
\$29.99 US
ISBN 978-1-63586-662-9

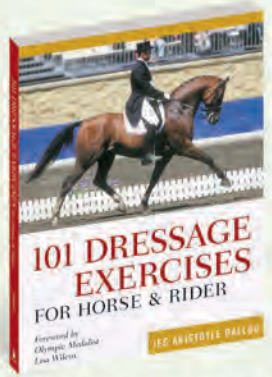

101 Dressage Exercises for Horse & Rider

JEC ARISTOTLE BALLOU
Moving from basic techniques to advanced maneuvers, the exercises here provide hours of satisfying dressage work for riders of all levels.

Paper; 240 pages; 8½ x 11
Illustrations throughout
\$29.99 US
ISBN 978-1-63586-663-6

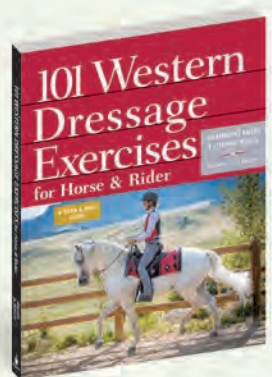

101 Western Dressage Exercises for Horse & Rider

JEC ARISTOTLE BALLOU & STEPHANIE BOYLES
Applying the principles of dressage to the training of Western horses, these exercises help riders take their horses to the next level.

Paper; 240 pages; 8½ x 10½
Photographs and illustrations throughout
\$29.99 US
ISBN 978-1-63586-661-2



Build Your Own Beekeeping Equipment

TONY PISANO
Illustrated with step-by-step instructions, these 35 building projects cover everything from hive components and frames to swarm catchers and even bear fences. All can be made using recycled materials and simple hand tools.

Paper; 160 pages; 8½ x 10½
One-color with 8-page color insert
\$19.95 US
ISBN 978-1-61212-059-1

"Beginners, dreamers, families, and educators will find this highly visual reference an indispensable guide to becoming a confident, happy beekeeper."
—Jenna Woginrich, author of *Barnheart and Made from Scratch*



Homegrown Honey Bees

ALETHEA MORRISON
PHOTOGRAPHY BY MARS VILAUDI
Discover the joys of harvesting honey from your own backyard. Alethea Morrison outlines what you'll need to know to make it through the first year, while stunning macrophotography by Mars Vilaubi brings the inner workings of the hive to life. With in-depth discussions of allergies, colony hierarchy, bee behavior, and more, this approachably informative guide bursts with enthusiastic encouragement. Keep your own bees, and enjoy the sweet buzz.

59,000 COPIES IN PRINT
Paper; 160 pages; 7 x 9
Full-color
\$15.99 US
ISBN 978-1-60342-994-8

"Kearney has woven together the soul and science of the honey bee. You'll see the bee and its place in the world like never before."
—Frederick Dunn, Cornell University Certified Master Beekeeper and host of *The Way To Bee*



Heart of the Hive

HILARY KEARNEY
Expert beekeeper and swarm-catcher Hilary Kearney offers a unique window into the social lives and biology of these remarkable creatures, accompanied by the photos of world-renowned bee photographer Eric Tourneret. Readers will be awestruck by the hive as superorganism and how the individual bee lives and behaves within it. This immersive journey into the world of bees offers an entirely new perspective on the wisdom of nature and our relationship to it.

Hardcover; 200 pages; 5½ x 7½
Full-color
\$28.00 US
ISBN 978-1-63586-483-0



Hive Management

RICHARD E. BONNEY
For the practicing beekeeper or the serious novice, this is an integrated year-round program of hive management season by season, explaining what to do and why. Beekeepers will get the knowledge and understanding they need to maintain a thriving hive.

44,000 COPIES IN PRINT
Paper; 160 pages; 6 x 9
Photographs and illustrations throughout
\$18.99 US
ISBN 978-0-88266-637-2



100 Plants to Feed the Bees

THE XERCES SOCIETY
This user-friendly field guide offers concise profiles of 100 common flowers, herbs, shrubs, and trees that attract and nourish bees, butterflies, moths, and hummingbirds.

66,000 COPIES IN PRINT
Garden Writers Association Silver Award of Achievement

Paper; 240 pages; 6 x 8
Full-color
\$18.99 US
ISBN 978-1-61212-701-9
Hardcover; **\$26.95 US**
ISBN 978-1-61212-886-3



Attracting Native Pollinators

THE XERCES SOCIETY
This essential reference provides comprehensive information on every kind of pollinator and shows how to encourage activity from bees, wasps, butterflies, moths, and flies by creating flowering habitats and inviting nesting sites. Anyone can do it! Instructions for building nesting structures and an extensive resource list are included.

55,000 COPIES IN PRINT
Paper; 348 pages; 7 x 10
Full-color
\$29.95 US
ISBN 978-1-60342-695-4

"Entertaining and educational. A great read for bee lovers and new-bees alike!"
—Melissa Hayes, MinuteEarth



QueenSpotting

HILARY KEARNEY
Beekeeper and swarm catcher Hilary Kearney brings the marvels and mysteries of honey bees to life, exploring happenings within the hive and creating an evocative portrait of the queen at the center of it all. Forty-eight photographic challenges invite readers to spot the queen among hundreds of bees, and accounts of Kearney's adventures rescuing wandering swarms will educate and captivate.

Hardcover; 128 plus 48 fold-out photo puzzles pages; 7 x 8
Full-color
\$19.99 US
ISBN 978-1-63586-037-5

BEST-SELLING SERIES STOREY'S GUIDES TO RAISING

NEWLY REVISED EDITIONS ensure the most trusted animal-husbandry series continues to be the go-to reference for the next generation of farmers and homesteaders.

- NOW WITH FULL-COLOR PHOTOS AND DIAGRAMS
- LARGER, FRIENDLIER TRIM SIZE
- UPDATED SECTIONS ON HEALTH CARE, BREEDING, MARKETING, AND MORE



Storey's Guide to Raising Sheep, 5th Edition

PAULA SIMMONS & CAROL EKARIUS

With expert coverage of everything from shearing a sheep to building a lambing shed, assisting with lambing, and much more, this is the essential bible for the shepherd.

Paper; 368 pages; 7 x 9 1/4
Full-color
\$24.95 US
ISBN 978-1-61212-980-8

Hardcover;
\$34.95 US
ISBN 978-1-61212-984-6

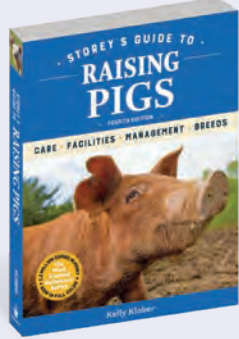

Storey's Guide to Raising Pigs, 4th Edition

KELLY KLOBER

This trusted resource provides authoritative advice on every aspect of raising pigs, with sections covering green farming methods and rare and heritage breeds.

Paper; 344 pages; 7 x 9 1/4
Full-color
\$24.95 US
ISBN 978-1-63586-042-9

Hardcover;
\$34.95 US
ISBN 978-1-63586-043-6

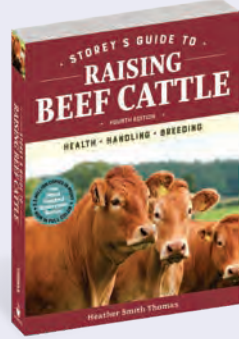

Storey's Guide to Raising Beef Cattle, 4th Edition

HEATHER SMITH THOMAS

Every cattle rancher needs this comprehensive, expert advice, which includes essential information on health care, raising grass-fed animals, toxic pasture plants, and much more.

Paper; 320 pages; 7 x 9 1/4
Full-color
\$24.95 US
ISBN 978-1-63586-039-9

Hardcover;
\$34.95 US
ISBN 978-1-63586-040-5



Storey's Guide to Raising Rabbits, 5th Edition

BOB BENNETT

This guide to raising rabbits for meat or fiber or as pets offers full-color breed photos and up-to-date information on preventive health care, treating diseases, marketing, and showing.

Paper; 240 pages; 7 x 9 1/4
Full-color
\$24.95 US
ISBN 978-1-61212-976-1

Hardcover;
\$34.95 US
ISBN 978-1-61212-982-2

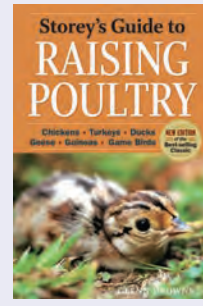

Storey's Guide to Raising Poultry, 4th Edition

GLENN DROWNS

This invaluable resource contains essential information on selection, housing, breeding, hatching, feeding, behavior, and health care.

Paper; 464 pages; 6 x 9
Illustrations throughout
\$19.99 US
ISBN 978-1-61212-000-3



Storey's Guide to Raising Turkeys, 3rd Edition

DON SCHRIDER

Turkeys produce lean, delicious, and nutritious meat. This essential reference covers breed selection, housing, feeding, breeding, health care, and much more.

Paper; 320 pages; 6 x 9
Illustrations throughout
\$19.99 US
ISBN 978-1-61212-149-9

Hardcover;
\$29.95 US
ISBN 978-1-61212-150-5



Storey's Guide to Raising Ducks, 2nd Edition

DAVE HOLDERREAD

From choosing the right breed to butchering, this essential guide covers it all, with an expanded breed section and helpful information on facilities, health care, and marketing.

Paper; 368 pages; 6 x 9
Photographs and illustrations throughout
\$19.95 US
ISBN 978-1-60342-692-3

OVER 2.7 MILLION COPIES IN PRINT

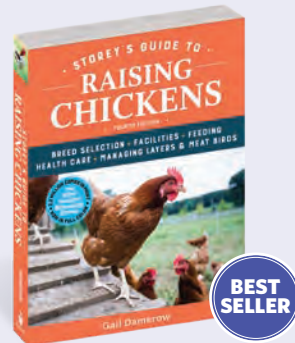
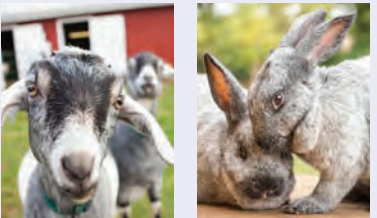
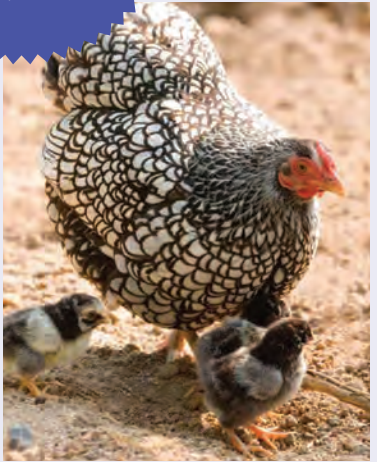

Storey's Guide to Raising Chickens, 4th Edition

GAIL DAMEROW

This reliable reference for flock owners brims with information on shelter, food, health care, eggs, chicks, meat, and recent research into chicken behavior and communication.

Paper; 424 pages; 7 x 9 1/4
Full-color
\$24.95 US
ISBN 978-1-61212-930-3

Hardcover;
\$34.95 US
ISBN 978-1-61212-934-1

BEST SELLER



Storey's Guide to Keeping Honey Bees, 2nd Edition

MALCOLM T. SANFORD & RICHARD E. BONNEY

From installing a colony and honey bee health to managing productive hives, this go-to reference covers everything new and experienced beekeepers need to know.

Paper; 224 pages; 7 x 9 1/4
Full-color
\$24.95 US
ISBN 978-1-61212-978-5

Hardcover;
\$34.95 US
ISBN 978-1-61212-983-9

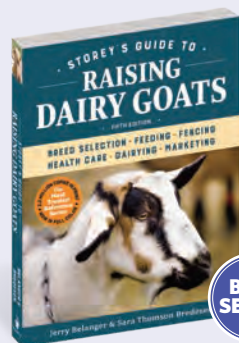

Storey's Guide to Raising Dairy Goats, 5th Edition

JERRY BELANGER & SARA THOMSON BREDESEN

Dairy goat raisers will keep a healthy, happy herd with this guide to housing, feeding, fencing, health, breeding, kidding, and milking.

Paper; 296 pages; 7 x 9 1/4
Full-color
\$24.95 US
ISBN 978-1-61212-932-7

Hardcover;
\$34.95 US
ISBN 978-1-61212-935-8

BEST SELLER

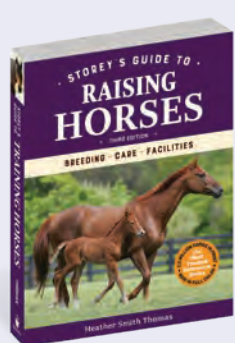

Storey's Guide to Raising Horses, 3rd Edition

HEATHER SMITH THOMAS

For everyone from experienced handlers to first-time buyers, this complete guide to raising horses covers all aspects of keeping a horse fit and healthy.

Paper; 448 pages; 7 x 9 1/4
Full-color
\$26.95 US
ISBN 978-1-63586-085-6

Hardcover;
\$36.95 US
ISBN 978-1-63586-086-3

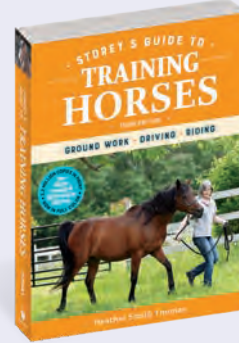

Storey's Guide to Training Horses, 3rd Edition

HEATHER SMITH THOMAS

This fully updated reference features a complete program for turning a shy, gangly foal into a calm, coordinated, and skillful equine partner, with a thorough grounding in both Western and English saddle work, driving, trailer training, and more.

Paper; 448 pages; 7 x 9 1/4
Full-color
\$24.95 US
ISBN 978-1-63586-120-4

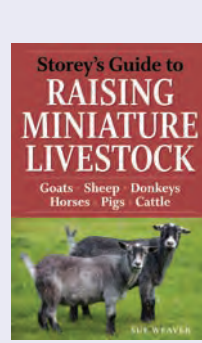

Storey's Guide to Raising Miniature Livestock

SUE WEAVER

New and experienced farmers alike will appreciate these clear explanations of the ins and outs of breeding, feeding, housing, diet, nutrition, exercise, disease prevention and treatment, and more.

Paper; 464 pages; 6 x 9
One-color with 16-page color insert
\$19.95 US
ISBN 978-1-60342-481-3

Hardcover;
\$29.95 US
ISBN 978-1-60342-482-0



Storey's Guide to Raising Meat Goats, 2nd Edition

MAGGIE SAYER

The essential reference on raising, caring for, and marketing meat goats also offers advice on starting or expanding a meat-goat business.

Paper; 344 pages; 6 x 9
Photographs and illustrations throughout
\$19.99 US
ISBN 978-1-60342-582-7

BEST-SELLING AUTHOR GAIL DAMEROW



“A must-have book for all chicken lovers.”
—Jeff Smith, Cackle Hatchery

The Chicken Health Handbook, 2nd Edition

Healthy chickens are happy chickens. This one-of-a-kind reference book covers the health problems that plague chickens of all breeds and ages. Practical charts identify common symptoms and causes of infection, while an alphabetic listing of diseases provides advice on treatment. You'll find helpful descriptions of troublesome ailments of all types, from poor egg production to crooked toe syndrome. Practical remedies and gentle preventative care measures will help your beloved flock stay happy, healthy, and safe.

Paper; 496 pages; 7 x 9 1/4
Full-color
\$24.95 US
ISBN 978-1-61212-013-3

Hardcover;
\$34.95 US
ISBN 978-1-61212-479-7



What's Killing My Chickens?

For backyard chicken keepers and large-scale farmers alike, the single greatest challenge is protecting poultry from predators. In this detective-style manual, chicken expert Gail Damerow teaches readers how to follow clues such as tracks, trails, scat, and other signs to identify the attacker.

Paper; 272 pages; 7 x 9 1/4
Full-color
\$19.95 US
ISBN 978-1-61212-909-9

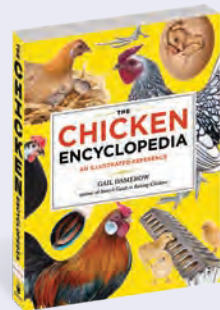

The Chicken Encyclopedia

From *addled* to *zygote*, chicken terminology is demystified in this informative and entertaining illustrated reference. Whether it's the characteristics of droopy wing or the translation of a chicken's alarm call, here are answers to every chicken owner's question and quandary.

■ **110,000 COPIES IN PRINT**
Paper; 320 pages; 7 x 9 1/4
Full-color
\$19.95 US
ISBN 978-1-60342-561-2

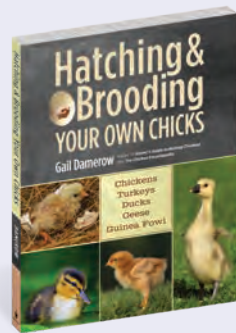

Hatching & Brooding Your Own Chicks

This authoritative guide explains how to hatch baby chickens, ducklings, goslings, turkey poults, and guinea keets, addressing everything from selecting a breed and choosing the best incubator to ensuring sanitary conditions and feeding newborns in a brooder.

Paper; 240 pages; 8 1/2 x 10 1/4
Full-color
\$24.99 US
ISBN 978-1-61212-014-0



An Absolute Beginner's Guide to Keeping Backyard Chickens

JENNA WOGINRICH
PHOTOGRAPHY BY
MARS VILAUBI

Delightful photographs chronicle the journey of three chickens as they grow from newly hatched chicks to adult hens laying eggs. Following their progress from day to day and week to week, absolute beginners will learn everything they need to know about chicken behavior, feeding, housing, hygiene, and health care.

Paper; 128 pages; 7 x 9
Full-color
\$14.95 US
ISBN 978-1-63586-518-9

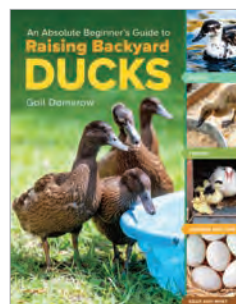

An Absolute Beginner's Guide to Raising Backyard Ducks

GAIL DAMEROW

This accessible introductory guide features original photography tracking the growth of a small flock of backyard ducks, and addresses breed selection, housing, feeding, health care, understanding behavior, and egg and meat production.

Paper; 160 pages; 7 x 9
Full-color
\$16.99 US
ISBN 978-1-63586-529-5



Let's All Keep Chickens!

DALIA MONTERROSO

Dalia Monterroso brings a fresh voice to the community of backyard chicken keeping with this entry-level guide focused on empowering beginners with confidence with a special emphasis on urban and suburban chicken raisers, low-cost options, and natural practices from around the world.

Paper; 192 pages; 7 x 9
Full-color
\$16.99 US
ISBN 978-1-63586-477-9



Hentopia

FRANK HYMAN

From the Vending Machine Feeder to the Refilling Rainwaterer, these innovative building projects are designed to save time and money. Featuring easy-to-follow instructions and colorful photos, the 21 projects for the chicken yard range from nest boxes, fencing, and roosts to a predator-proof pen, and a sturdy but inexpensive coop made from wooden pallets.

Paper; 208 pages; 8 x 10
Full-color
\$24.95 US
ISBN 978-1-61212-994-5

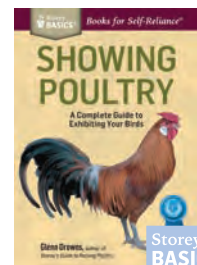

Showing Poultry

GLENN DROWN

For poultry raisers who want to show their best birds to others, this book offers all the guidance needed to be successful at exhibiting in county and state fairs and expositions, from selecting the best breeds to proper diet, care, and handling; cage training; and judging standards.

Paper; 88 pages; 5 x 7
Illustrations throughout
\$8.95 US
ISBN 978-1-61212-529-9

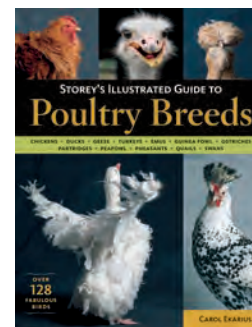

Storey's Illustrated Guide to Poultry Breeds

CAROL EKARIUS

For farmers and fanciers alike, here is the definitive guide to North American poultry, with more than 120 breeds strutting their stuff. Laying hens, heritage turkeys, exotic pheasants, and giant ostriches come to life with charming color photography, breed histories, and thorough descriptions of physical characteristics.

■ **81,000 COPIES IN PRINT**
Paper; 288 pages; 8 1/2 x 10 1/4
Full-color
\$24.95 US
ISBN 978-1-58017-667-5

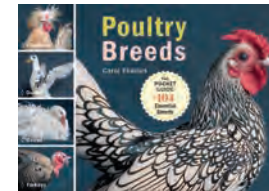

Poultry Breeds

CAROL EKARIUS

Stunning photos highlight the beauty and unique attributes of 104 poultry breeds. Each profile outlines the bird's history, physical characteristics, and common uses, with specially noted fun facts sprinkled throughout.

Paper; 272 pages; 6 x 4 1/4
Full-color
\$12.95 US
ISBN 978-1-61212-692-0

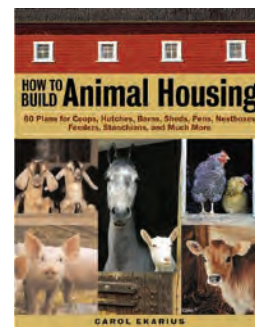

How to Build Animal Housing

CAROL EKARIUS

For the wide range of barnyard animals living on small-scale farms, here is a collection of 60 building plans for shelters that meet each animal's needs. There are sheds, coops, hutches, multipurpose barns, windbreaks, and shade structures, plus designs for watering systems, feeders, chutes, stanchions, and more.

■ **86,000 COPIES IN PRINT**
Paper; 272 pages; 8 1/2 x 10 1/4
Illustrations throughout
\$24.95 US
ISBN 978-1-58017-527-2

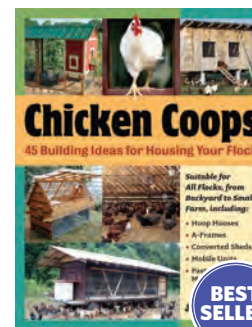

Chicken Coops

JUDY PANGMAN

Just like houses, chicken coops come in all sizes and styles. Here are basic plans, elevation drawings, and building ideas for 45 original coops, from the strictly practical to the fanciful. An eight-page color section shows detailed photos of many of the featured coops.

■ **137,000 COPIES IN PRINT**
Paper; 176 pages; 8 1/2 x 10 1/4
One-color with 8-page color insert
\$19.99 US
ISBN 978-1-58017-627-9



Reinventing the Chicken Coop

KEVIN MCELROY & MATTHEW WOLPE

Backyard chickens meet contemporary design! These 14 complete building plans for chicken coops range from the purely functional to the outrageously fabulous. Some are suitable for beginning builders, and others are challenging enough for experts. All are accompanied by detailed construction illustrations.

■ **40,000 COPIES IN PRINT**
Paper; 192 pages; 9 x 9 1/2
Full-color
\$19.95 US
ISBN 978-1-60342-980-1

BEST-SELLING AUTHOR MELISSA CAUGHEY



My Chicken Family

A beautifully designed keepsake album that invites chicken owners to create a lasting record of their chicken adventures, with spots for adding photos of their favorite flock members and write-in prompts customized to every phase of the chicken-keeping experience.

Hardcover; 80 pages; 9 1/4 x 9 1/4
Full-color
\$16.00 US
ISBN 978-1-63586-535-6



How to Speak Chicken

Combining her own observations with scientific findings, interviews, and colorful art, Melissa Caughey answers unexpected questions such as *Do chickens have names for each other?* and *How do their eyes work?* and *How do chickens learn?*

■ **175,000 COPIES IN PRINT**
Silver Foreword INDIES Award

Paper; 144 pages; 6 x 8
Full-color
\$16.95 US
ISBN 978-1-61212-911-2



A Kid's Guide to Keeping Chickens

Kids can learn practical tips on housing, food, and equipment before bringing home their first chicks. Egg-centric dishes and crafts offer hours of fun.

■ For ages 8-12
■ AAAS/Subaru Award
■ Teachers' Choice Award for the Family
■ **68,000 COPIES IN PRINT**

Paper with pull-out poster; 144 pages; 7 1/2 x 9 3/4
Full-color
\$16.95 US
ISBN 978-1-61212-418-6



Chicken Wisdom Frame-Ups

Sage and inspiring sentiments come together with delightful chicken photography in this collection of 50 individual, display-worthy cards. With a pull-out tabletop frame included, chicken enthusiasts and animal lovers can show off their favorite card or easily swap it out for one that fits the mood or suits the moment.

Paper with stand-up cardstock easel; 100 pages; 7 1/2 x 7
Full-color
\$14.95 US
ISBN 978-1-63586-243-0

BEST-SELLING AUTHOR TEMPLE GRANDIN



“Through keen observation, adaptive handling techniques, and intuitive predictions of animal behaviors and reactions, the small farmer can safely and compassionately tend [livestock].”

—Booklist

Temple Grandin’s Guide to Working with Farm Animals

Temple Grandin’s explanations of how herd animals think and how to analyze their behavior will help small-scale farmers and homesteaders managing a small herd of 3 to 25 cattle or pigs, or 5 to 100 goats or sheep, become more effective at safely handling their livestock.

Paper; 192 pages; 7½ x 10
Full-color
\$22.99 US
ISBN 978-1-61212-744-6

Hardcover;
\$29.95 US
ISBN 978-1-61212-760-6

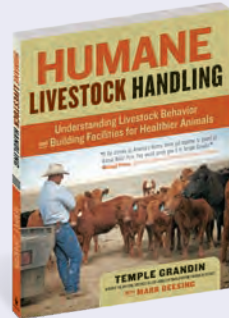

“An excellent book on how to incorporate an understanding of animal behavior to safely and calmly handle livestock for profitability and gratification.”

—Small Farm Today

Humane Livestock Handling

TEMPLE GRANDIN WITH MARK DEESING

Well-treated animals are healthier and calmer and deliver higher yields of marketable meat. Temple Grandin describes low-stress methods for handling cattle and provides construction plans for humane chutes, corrals, and sorting pens. Her facility designs show farmers how to process meat safely, efficiently, and humanely.

■ **37,000 COPIES IN PRINT**

Paper; 240 pages; 8½ x 10½
Illustrations throughout
\$24.99 US
ISBN 978-1-60342-028-0



TEMPLE GRANDIN, PhD, is the best-selling author of books on animal behavior and humane livestock handling. She consults on animal welfare to the fast-food industry, and her life was the subject of an Emmy Award-winning HBO movie. Grandin is a professor of animal science at Colorado State University.

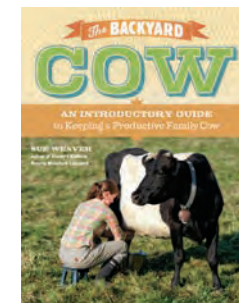

The Backyard Cow

SUE WEAVER

With this insightful guidebook to bovine care, hobby farmers and families will be able to select the most appropriate breed, understand their cow’s behavior, and provide adequate shelter, health care, and daily maintenance.

Paper; 240 pages; 7 x 9
One-color with 16-page color insert
\$18.95 US
ISBN 978-1-60342-997-9

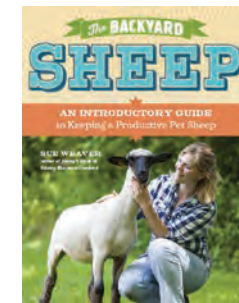

The Backyard Sheep

SUE WEAVER

Whether keeping two sheep or a dozen on a small plot of land, this go-to reference offers beginners guidance on breed selection, sheep health and safety, lambing, milking, and ensuring production of beautiful fleece and delicious dairy.

Paper; 224 pages; 7 x 9
One-color with 16-page full-color insert
\$16.95 US
ISBN 978-1-60342-967-2



The Backyard Goat

SUE WEAVER

For anyone who wants to keep goats, this book covers the essentials, from choosing the right goats to health, housing, feeding, milking, kidding, and training them for harness work or to serve as pack goats.

■ **45,000 COPIES IN PRINT**

Paper; 224 pages; 7 x 9
One-color with 16-page full-color insert
\$16.95 US
ISBN 978-1-60342-790-6

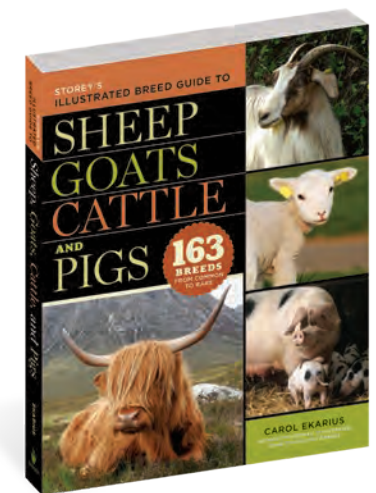

Storey’s Illustrated Breed Guide to Sheep, Goats, Cattle, and Pigs

CAROL EKARIUS

Comprehensive, colorful, and captivating, this at-a-glance reference covers 163 common and heritage North American breeds of cattle, goats, sheep, and pigs, with brief breed histories; information on unique quirks, qualities, and uses; and conservation status.

Paper; 320 pages; 8½ x 10½
Full-color
\$24.95 US
ISBN 978-1-60342-036-5

Hardcover with jacket;
\$34.95 US
ISBN 978-1-60342-037-2

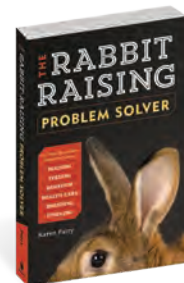

“An excellent, well-written book that will become a classic resource for experienced and novice rabbit breeders.”

—Don Atchison, President of the National Rex Rabbit Club

The Rabbit-Raising Problem Solver

KAREN PATRY

In a handy question-and-answer format Karen Patry expertly addresses every aspect of rabbit care, including housing, feeding, breeding, kindling, health, and behavior. This informative, easy-to-use guide has reliable, humane solutions that will keep your animals healthy and happy, whether they raise their animals as pets, for meat, or for fiber.

Paper; 328 pages; 6 x 9
Illustrations throughout
\$19.99 US
ISBN 978-1-61212-142-0



Rabbit Housing

BOB BENNETT

Here are plans for designing and building efficient facilities that shelter 2 to 100 backyard rabbits in safety and comfort. The book also guides readers through options for feeders, watering systems, nest boxes, and sheltering structures.

Paper; 144 pages; 8½ x 10½
One-color with 8-page color insert
\$19.95 US
ISBN 978-1-60342-966-5



Rabbit Breeds

LYNN M. STONE

This pocket-size reference spotlights all 49 breeds recognized by the American Rabbit Breeders Association with engaging descriptions and fun facts. Beautiful original photographs anchor each profile, while a playful history of rabbit domestication and glossaries of rabbit terminology and colors round out the collection.

Paper; 256 pages; 6 x 4½
Full-color
\$10.95 US
ISBN 978-1-61212-602-9

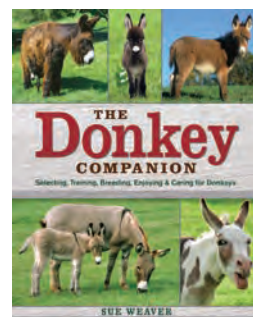

The Donkey Companion

SUE WEAVER

Friendly, dependable donkeys can pull carts, carry riders, tote gear, and act as stable companions and livestock guardians. From foaling and first aid to grooming and professional showing, this guide offers everything a donkey owner needs to know.

■ **39,000 COPIES IN PRINT**
Paper; 352 pages; 8 x 10
One-color with 16-page color insert
\$29.95 US
ISBN 978-1-60342-038-9



Homegrown Pork

SUE WEAVER

Pigs are an efficient and flavorful choice for the backyard meat producer, and this expert handbook outlines every aspect of choosing, raising, understanding, and caring for a pig, as well as meat processing at the slaughterhouse or at home.

Paper; 256 pages; 7 x 9
One-color with 8-page color insert
\$18.95 US
ISBN 978-1-61212-126-0

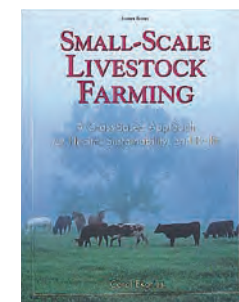

Small-Scale Livestock Farming

CAROL EKARIUS

A grass-based, organic approach to livestock management produces healthier animals, reduces feed and healthcare costs, and maximizes profit. This guide to creating a prosperous small-scale livestock farm includes case studies of successful farmers, planning tips, and more.

■ **58,000 COPIES IN PRINT**

Paper; 224 pages; 8½ x 11
Illustrations throughout
\$19.95 US
ISBN 978-1-58017-162-5



The Backyard Homestead Guide to Raising Farm Animals

EDITED BY GAIL DAMEROW

Anyone can raise chickens, ducks, geese, turkeys, rabbits, goats, sheep, cows, pigs, and honey bees—even in cities and suburbs. This book covers all the basics of feed, housing, health care, and much more.

■ **105,000 COPIES IN PRINT**

Paper; 360 pages; 8½ x 10½
Two-color with 8-page full-color fold-out insert
\$24.99 US
ISBN 978-1-60342-969-6



Lincoln Longwool



Ancient White Park



Nubian



Meishan

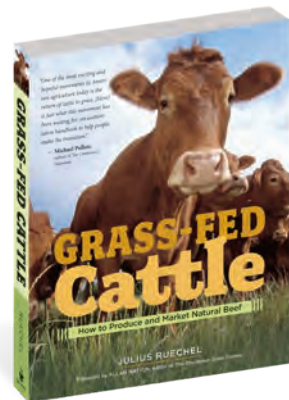

“An authoritative handbook on one of the most exciting and hopeful movements in American agriculture today—the return of cattle to grass.”

—Michael Pollan, author of *The Omnivore’s Dilemma*

Grass-Fed Cattle

JULIUS RUECHEL

As more consumers discover the benefits of grass-fed beef—sustainable, delicious, antibiotic-free—demand continues to grow. For any farmer interested in entering this profitable specialty area, here is advice on herd selection, pasture management, winter grazing, equipment, slaughter, labeling, marketing, and more.

■ **43,000 COPIES IN PRINT**

Paper; 384 pages; 8½ x 10½
 Illustrations throughout
\$29.95 US

ISBN 978-1-58017-605-7

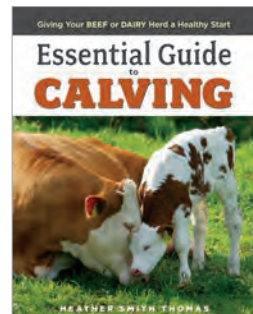

Essential Guide to Calving

HEATHER SMITH THOMAS

Healthy pregnancies, safe births, and thriving calves are critical to every cattle-farming operation. Here is complete coverage of what to expect at every step of the calving process and how to keep calves healthy through the first year of life.

Paper; 336 pages; 8½ x 10½
 Photographs and illustrations throughout
\$34.99 US
 ISBN 978-1-58017-706-1

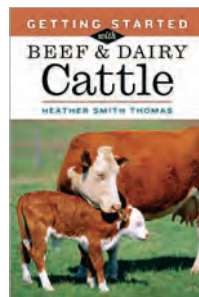

Getting Started with Beef & Dairy Cattle

HEATHER SMITH THOMAS

All the basics of cattle farming are covered in this first-time farmer’s guide to raising a family cow or a small herd for milk or beef, from breed selection and health care to feeding, calving, and bringing products to market.

Paper; 288 pages; 6 x 9
 One-color with 16-page color insert
\$16.95 US
 ISBN 978-1-58017-596-8

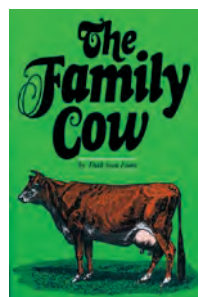

The Family Cow

DIRK VAN LOON

Keeping a single cow requires just a little land and offers big benefits. This book provides all the basics of keeping a cow, from bovine history and breeds to fencing, nutritional requirements, milking, using manure, and more.

Paper; 272 pages; 6 x 9
 Photographs and illustrations throughout
\$19.99 US
 ISBN 978-0-88266-066-0

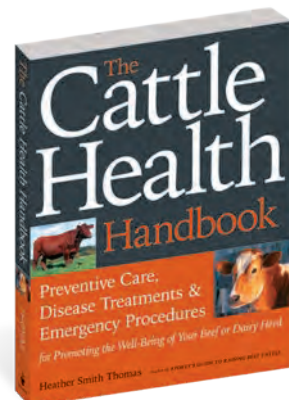

The Cattle Health Handbook

HEATHER SMITH THOMAS

For novice and experienced ranchers alike, this reliable medical reference offers expert advice from rancher and prolific animal health care author Heather Smith Thomas. Covering topics ranging from providing the day-to-day care cattle require and preventive health practices to easy-to-execute solutions for treating common diseases, ailments, and injuries—including bacterial diseases, parasites, nutritional deficiencies, and more—this handbook is a must-have for anyone caring for cattle.

Paper; 384 pages; 8½ x 10½
 Illustrations throughout
\$29.95 US

ISBN 978-1-60342-090-7

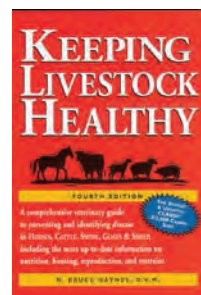

Keeping Livestock Healthy

N. BRUCE HAYNES, DVM

For livestock owners and farm workers alike, this comprehensive veterinary reference helps prevent disease in horses, cattle, pigs, goats, and sheep through proper nutrition, housing, and care and includes information on vaccines, disease testing, and drug treatments.

Paper; 352 pages; 6 x 9
 Photographs and illustrations throughout
\$22.99 US
 ISBN 978-1-58017-435-0



Tan Your Hide!

PHYLLIS HOBSON

Articles made from home-tanned leathers and furs are handsome and durable. With this step-by-step guide, readers will learn to prepare skins and use them to make belts, wallets, holsters, pillows, vests, hats, mittens, and more.

Paper; 144 pages; 6 x 9
 Illustrations throughout
\$14.99 US
 ISBN 978-0-88266-101-8

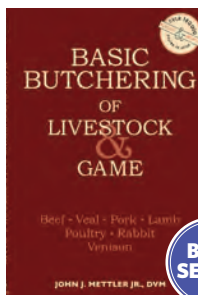

Basic Butchering of Livestock & Game

JOHN J. METTLER JR., DVM

Detailed instructions and easy-to-follow illustrations demystify slaughtering and butchering from start to finish. This classic covers beef, veal, venison, pork, lamb, and poultry and includes 30 recipes.

■ **285,000 COPIES IN PRINT**
Paper; 208 pages; 6 x 9
 Illustrations throughout
\$17.99 US
 ISBN 978-0-88266-391-3

BEST-SELLING AUTHOR ADAM DANFORTH

... “What’s more, this is not just academic data: there are practical applications, and not only for homestead butchers. Anyone who cooks or eats meat would benefit from much of this information.”

—HobbyFarms.com

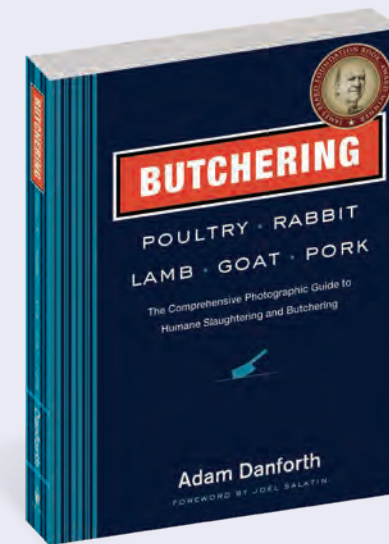

Butchering Poultry, Rabbit, Lamb, Goat, and Pork

Slaughter and butcher your own animals safely and humanely with this award-winning guide. Providing detailed photography of every step of the process, Adam Danforth shows you everything you need to know to butcher poultry, rabbit, lamb, goat, and pork. Learn how to create the proper slaughtering conditions, break the meat down, and produce flavorful cuts of meat. Stressing proper food safety at all times, Danforth provides expert advice on necessary tools and helpful tips on freezing and packaging. Enjoy the delicious satisfaction that comes with butchering your own meat.

■ James Beard Award ■ IACP Award
 ■ **59,000 COPIES IN PRINT**

Paper; 456 pages; 8½ x 10½
 Full-color
\$34.99 US
 ISBN 978-1-61212-182-6

Hardcover;
\$45.00 US
 ISBN 978-1-61212-188-8



Butchering Beef

Learn how to humanely slaughter cattle and butcher your own beef. In this straightforward guide, Adam Danforth provides clear instructions and step-by-step photography of the entire butchering process, from creating the right preslaughter conditions through killing, skinning, keeping cold, breaking the meat down, and perfecting expert cuts. With plenty of encouragement and expert advice on food safety, packaging, and necessary equipment, this comprehensive guide has all the information you need to start butchering your own beef.

Paper; 352 pages; 8½ x 10½
 Full-color
\$34.99 US
 ISBN 978-1-61212-183-3

Hardcover;
\$45.00 US
 ISBN 978-1-61212-189-5



To excel at butchering, you need only a few basic, modestly priced tools.



The frequent use of a honing rod is one of the keys to maintaining knife sharpness.



Deceptively simple in appearance, tub pluckers quickly turn a feathered bird into a clean carcass.



Butchering Chickens

For backyard chicken keepers and small-farm operations invested in raising meat responsibly, this visual guide makes the entire slaughtering and butchering process accessible. Focused specifically on working with chickens, expert butcher and teacher Adam Danforth delivers detailed instructions and step-by-step photos, with chapters dedicated to tools and equipment; essential food safety measures; preparing for slaughter and processing birds quickly and humanely; breaking down carcasses into cuts; and packaging and freezing cuts to ensure freshness.

Paper; 176 pages; 7 x 9
 Full-color
\$18.95 US
 ISBN 978-1-63586-165-5

... “On a scale of 1-10, these easily rank 12, minimum.”

—HobbyFarms.com

“These are not mere how-to guides: they are the equivalent of in-depth college courses.”

—HobbyFarms.com

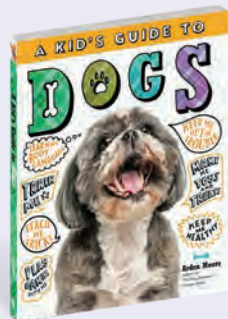

A Kid's Guide to Dogs

ARDEN MOORE

Fun, informative, and full of colorful photos and illustrations, this canine care handbook for young dog lovers teaches kids how to decode a dog's body language, perform a wellness checkup, and train a new pup. It even offers easy crafts and dozens of ideas for getting both kids and dogs active. Lively trivia quizzes, "Ask the Vet" Q&As, and dog breed profiles make this the perfect guide for new and seasoned dog companions.

Paper; 144 pages; 7 x 9
Full-color
\$14.95 US
ISBN 978-1-63586-098-6
Hardcover;
\$24.95 US
ISBN 978-1-63586-099-3

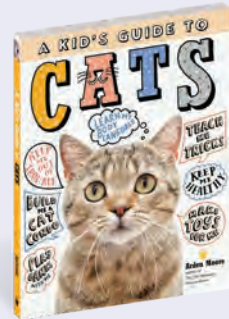

A Kid's Guide to Cats

ARDEN MOORE

Combining humor with plenty of practical advice, this lively guide equips kids with everything they need to know to be great cat caretakers and companions. Young cat lovers will learn how to read a cat's body language, proper litter box protocol, fun facts about the history of cat-human relationships, and why cats purr. Special features include "Ask the Vet" Q&As, trivia quizzes, DIY cat toys, and more.

Paper; 144 pages; 7 x 9
Full-color
\$14.95 US
ISBN 978-1-63586-101-3
Hardcover;
\$25.00 US
ISBN 978-1-63586-102-0

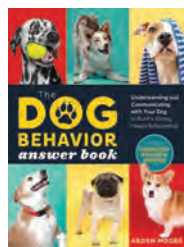

The Dog Behavior Answer Book, 2nd Edition

ARDEN MOORE
FOREWORD BY JOHN GROGAN

Real dogs' behavioral issues inspired the questions addressed in this friendly handbook with thorough explanations for everything from how dogs know their owners are coming home to why some dogs drink from the toilet bowl—and what to do about it.

Paper; 272 pages; 6 x 8
Full-color
\$16.99 US
ISBN 978-1-63586-451-9

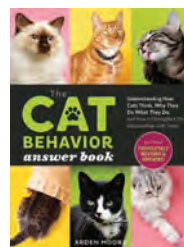

The Cat Behavior Answer Book, 2nd Edition

ARDEN MOORE
FOREWORD BY NANCY PETERSON, RVT

This browsable Q&A handbook invites cat lovers to better understand their companions. Practical advice and workable solutions to common kitty conundrums help prevent destructive behavior and embrace feline friends' charming quirks.

Paper; 272 pages; 6 x 8
Full-color
\$16.99 US
ISBN 978-1-63586-449-6



Compact Farms

JOSH VOLK

Small is beautiful, and these 15 real farm plans show that small-scale farmers can have big-time success. *Compact Farms* is an illustrated guide for anyone dreaming of starting, expanding, or perfecting a profitable farming enterprise on five acres or less. The farm plans explain how to harness an area's water supply, orientation, and geography in order to maximize efficiency and productivity while minimizing effort. Profiles of well-known farmers such as Eliot Coleman and Jean-Martin Fortier show that farming on a small scale in any region, in both urban and rural settings, can provide enough income to turn the endeavor from hobby to career. These real-life plans and down-and-dirty advice will equip you with everything you need to actually realize your farm dreams.

■ **46,000 COPIES IN PRINT**

Paper; 240 pages; 8 x 10
Full-color
\$19.95 US
ISBN 978-1-61212-594-7

"A trove of inspiration and practical advice for the next wave of young farmers. Even experienced farmers will glean new wisdom from the thoughtful tools and careful techniques in this book."

— **Lindsey Lusher Shute**, National Young Farmers Coalition executive director and co-founder



"Tools are such an important aspect of how we farm, why not build your own! This book is a little gem."

—Jean-Martin Fortier

Build Your Own Farm Tools

JOSH VOLK

For farmers with small-scale operations, the author of the best-selling *Compact Farms*, Josh Volk, offers an in-depth guide to building customized equipment that will save time, labor, and money. Beginning with the basics, such as workshop setup and safety considerations, Volk presents step-by-step illustrated instructions for making 19 tools suited to small-farm tasks and processes, including self-watering seedling benches, a mini barrel washer, a DIY germination chamber, and a rolling pack table. Projects range from the super-simple (requiring less than an hour to build) to the more complex and include tips for customizing the finished product. In addition, thoughtful planning and data collection tools will increase on-farm efficiency.

Paper; 208 pages; 8 x 10
Illustrations throughout
\$19.95 US
ISBN 978-1-63586-320-8



Animal Friends: Hello, Dogs!

EDITORS OF STOREY PUBLISHING

Dog-loving kids ages 4 and up learn all about the various breeds of dogs; how they see, hear, and communicate in this lively introduction to everything about dogs. Fifty stickers are included, along with a fold-out activity log.

■ For ages 4-8

Hardcover; 48 pages; 7 x 9
Full-color
\$14.99 US
ISBN 978-1-63586-776-3



Cute, Cuddly Tattoo Cats & Kittens

EDITORS OF STOREY PUBLISHING

A collection of 50 colorful, kid-friendly temporary tattoos featuring a wide range of breeds, colors, sizes, and poses. This *Tattoos that Teach* book includes text pages with fun facts about cat breeds, behavior, and origins.

Paper; 20 pages; 5½ x 10
Full-color
\$8.99 US
ISBN 978-1-63586-797-8



Furry, Friendly Tattoo Dogs & Puppies

EDITORS OF STOREY PUBLISHING

A collection of 60 colorful temporary tattoos featuring illustrations of favorite breeds and irresistibly cute puppies. The accompanying text pages in this *Tattoos that Teach* book feature fun facts about dogs and puppies, breeds and behaviors, and more.

Paper; 20 pages; 5½ x 10
Full-color
\$8.99 US
ISBN 978-1-63586-798-5

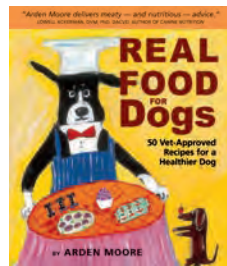

Real Food for Dogs

ARDEN MOORE
ILLUSTRATED BY ANNE DAVIS

From Great Gravy Cookies to Marvelous Mutt Meatballs, these 50 nutritionally balanced, easy-to-prepare recipes offer dog owners who want the very best for their canine companions a healthy, homemade occasional alternative to store-bought food.

■ **92,000 COPIES IN PRINT**

Paper; 128 pages; 6½ x 7½
Illustrations throughout
\$12.95 US
ISBN 978-1-58017-424-4

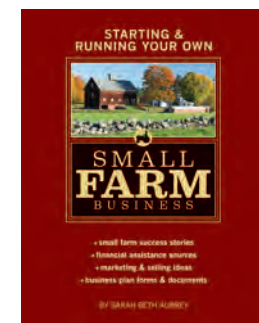

Starting & Running Your Own Small Farm Business

SARAH BETH AUBREY

After growing, raising, and crafting artisanal products, small-scale farmers also have to market and sell their items to wholesalers, retailers, and consumers. This business-savvy reference covers everything from financial plans and advertising budgets to website design and food-service wholesalers.

Paper; 176 pages; 8½ x 10½
Photographs and illustrations throughout
\$19.99 US
ISBN 978-1-58017-697-2

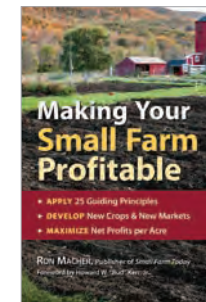

Making Your Small Farm Profitable

RON MACHER

Whether readers are buying a new farm or jump-starting an old one, this down-to-earth guide explains how to make a small farm reap big pay. Expert advice helps readers identify the right products to focus on and learn to process and promote them effectively.

■ **59,000 COPIES IN PRINT**

Paper; 288 pages; 6 x 9
Photographs and illustrations throughout
\$19.99 US
ISBN 978-1-58017-161-8



The "Have-More" Plan

ED & CAROLYN ROBINSON

First published in 1943, this back-to-the-land classic has taught generations of homesteaders practical techniques for creating a productive life in the country, from finding land and barn-building to gardening and raising livestock.

■ **533,000 COPIES IN PRINT**

Paper; 72 pages; 9 x 12
Photographs and illustrations throughout
\$12.99 US
ISBN 978-0-88266-024-0

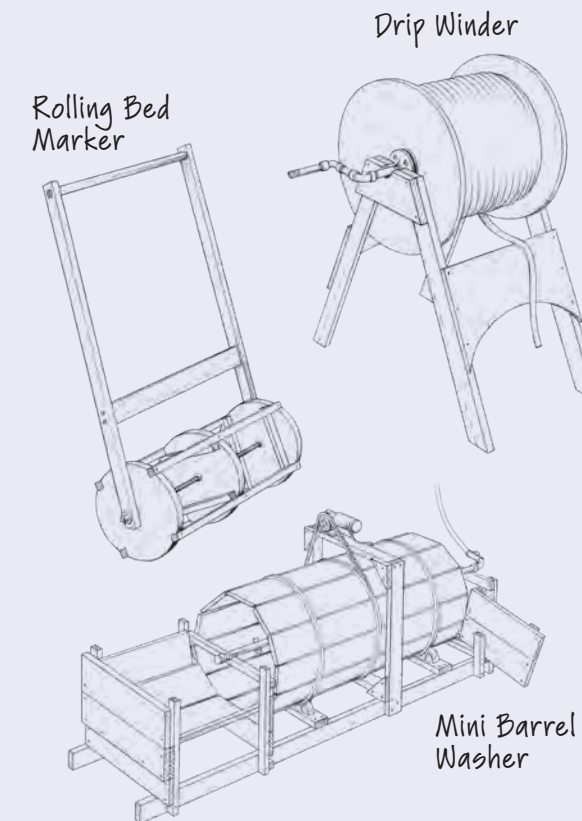

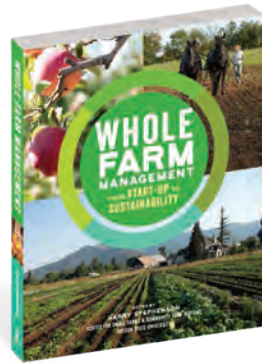

“Whole Farm Management empowers anyone to start planting seeds for a future farm business.”

—Lisa Kivirist, author of *Soil Sisters: A Toolkit for Women Farmers and Homemade for Sale*

Whole Farm Management

EDITED BY GARRY STEPHENSON

Developed by Oregon State University’s Small Farms Program, this essential handbook helps aspiring and beginner farmers make smart, strategic business decisions to ensure lasting success. Readers explore critical steps in starting, growing, and maintaining a farm or ranch, and farm case studies provide real-life examples of management practices in use.

Paper; 312 pages; 8 x 10
Full-color
\$26.95 US
ISBN 978-1-63586-074-0

DREAM IT



DO IT



SELL IT



MANAGE IT

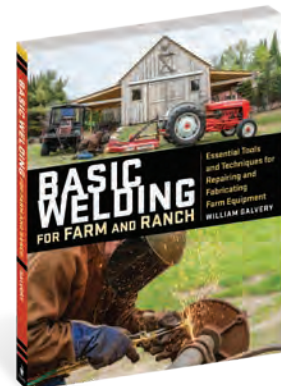

Basic Welding for Farm and Ranch

WILLIAM GALVERY

For farmers, ranchers, and homesteaders, knowing how to weld can prolong the life of essential equipment and save both time and money. From detailed coverage of the welding methods most commonly required on the farm to repair instructions and fabrication projects geared toward farm-related needs and scenarios, this guide provides self-sufficient readers with the fundamentals they need.

Paper; 256 pages; 8½ x 10½
Full-color
\$24.95 US
ISBN 978-1-61212-878-8

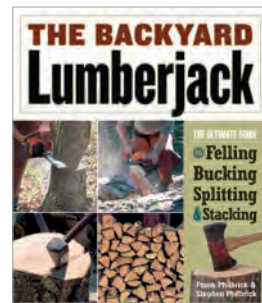

The Backyard Lumberjack

FRANK PHILBRICK & STEPHEN PHILBRICK

In this complete wood-cutting reference, Frank and Stephen Philbrick share their enthusiasm for the pleasures and rigors of bringing down trees, exploring subjects from choosing the perfect chainsaw to safely felling, bucking, splitting, and stacking wood.

Paper; 176 pages; 8 x 9¼
Full-color
\$18.95 US
ISBN 978-1-58017-634-7

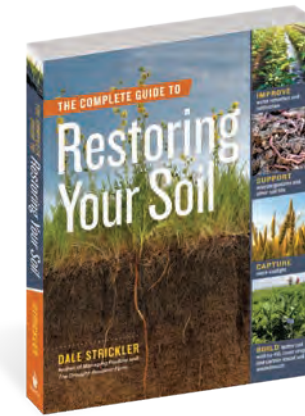

The Complete Guide to Restoring Your Soil

DALE STRICKLER

Healthy soil is key to sustaining life on Earth. While more and more people are starting to see the need for soil restoration, there is very little understanding of just how it can be accomplished. There is a rapidly emerging demand for a “how to” manual for soil restoration. Dale Strickler is an expert on building healthy soil and restoring degraded soil, and in *The Complete Guide to Restoring Your Soil*, he presents the science of soil, along with proven methods of restoring depleted soil and agricultural practices from around the world that continue to build soil, rather than cause it to

Paper; 352 pages; 8 x 10
Full-color
\$24.95 US
ISBN 978-1-63586-224-9

“Strickler gives us the tools to heal our damaged soil. This book should be on the shelf of every soil scientist, farmer, rancher, gardener, politician, landscaper, and informed citizen.”

—Hank Will, editor at large for Mother Earth News

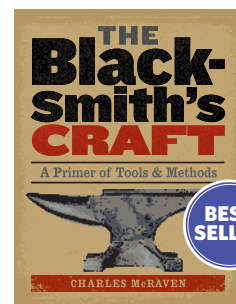

The Blacksmith's Craft

CHARLES McRAVEN

With this expert guide, aspiring smiths learn how to build a forge, make or acquire essential tools of the trade, and use techniques such as hammering iron, tempering steel, and forge welding to create items of lasting beauty and durability.

■ **87,000 COPIES IN PRINT**

Paper; 256 pages; 7 x 9
Photographs and illustrations throughout
\$19.95 US
ISBN 978-1-58017-593-7



A Landowner's Guide to Managing Your Woods

ANN LARKIN HANSEN, MIKE SEVERSON & DENNIS L. WATERMAN

This introductory resource explains how to sustainably manage a wooded property, from a few acres to a small commercial forest, with expert advice on assessing and improving tree health, ecosystem and wildlife habitat development, harvesting timber, and more.

Paper; 304 pages; 6 x 9
Illustrations throughout
\$19.95 US
ISBN 978-1-60342-800-2

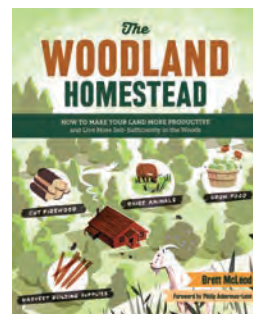

The Woodland Homestead

BRETT McLEOD

This innovative guide explains how to successfully use the forest’s resources to grow food, raise livestock, harvest wood, and much more.

Paper; 240 pages; 8 x 10
Two-color
\$19.95 US
ISBN 978-1-61212-349-3



100 Skills You'll Need for the End of the World (as We Know It)

ANA MARIA SPAGNA

What will we have to know how to do when the modern world is changed beyond recognition? These quirky illustrated interpretations reflect the simplicity that so many yearn for in today’s technology-driven existence.

■ Gold Nautilus Award

Paper; 224 pages; 5 x 7
Full-color
\$14.95 US
ISBN 978-1-61212-456-8



The Organic Farming Manual

ANN LARKIN HANSEN

Explaining the benefits of farming organically, this comprehensive guide details everything farmers need to know to grow, certify, and market organic produce, grains, meat, and dairy.

Paper; 448 pages; 8½ x 10½
Photographs and illustrations throughout
\$29.95 US
ISBN 978-1-60342-479-0



Farming with Native Beneficial Insects

THE XERCES SOCIETY

Encouraging native beneficial insects helps control pests, increase crop yield, and improve biodiversity. This comprehensive guide shows how to recognize and protect these insects and their habitats.

Paper; 272 pages; 7 x 10
Full-color
\$24.95 US
ISBN 978-1-61212-283-0

AUTHOR DALE STRICKLER

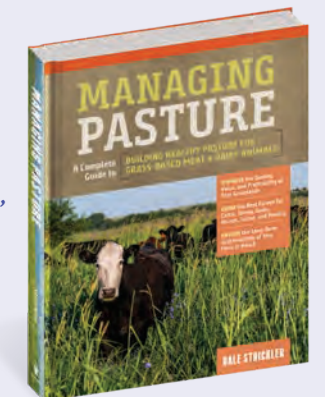

“If you want to understand why sustainable practices work, read this book.”

—Victoria G. Myers, senior editor, *The Progressive Farmer*

Managing Pasture

The health and profitability of grass-based livestock begin with the food they eat. With rancher and agronomist Dale Strickler’s approachable guide to creating healthy pastures, farmers and ranchers will learn to implement grazing and land management practices that go beyond better meat and dairy to increase profits, provide environmental benefits, and lead to long-term grassland improvement.

Hardcover; 288 pages; 8 x 10
Full-color
\$35.00 US
ISBN 978-1-63586-070-2

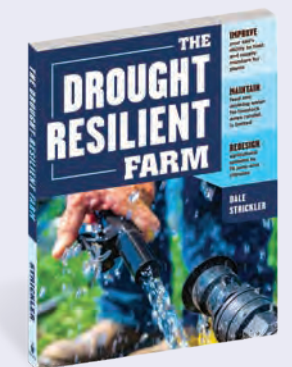

“When farmers ask me for direction on cover crops or soil health, I point them to Dale Strickler.”

—Donn Teske, vice president of the National Farmers Union

The Drought-Resilient Farm

Dale Strickler transformed his own drought-stricken family farm in Kansas into a water-wise, profitable enterprise. Now he introduces readers to the innovative methods he has used to hold more water in the soil and help plants and livestock access it.

Paper; 200 pages; 7 x 9
Full-color
\$24.95 US
ISBN 978-1-63586-002-3

BEST-SELLING SERIES THE BACKYARD HOMESTEAD

750,000 COPIES IN PRINT

Invaluable References for How to Live Successfully off the Land

For more than 10 years, the Backyard Homestead series has taught anyone with as little as one-quarter acre of land how to grow food, raise animals, improve their facilities, and enjoy the fruits of a productive, year-round family farm.

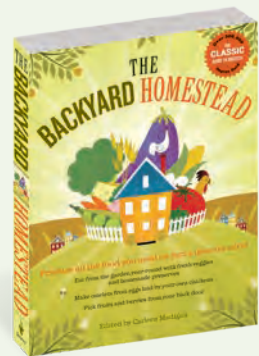

“This fascinating, friendly book is brimming with ideas, illustrations, and enthusiasm.”
—New York Times

The Backyard Homestead

EDITED BY CARLEEN MADIGAN

Put that backyard to work! Just one-quarter acre can yield 1,400 eggs, 50 pounds of wheat, 60 pounds of fruit, 2,000 pounds of vegetables, 280 pounds of pork, and 75 pounds of nuts. Plant, grow, harvest, cook, brew, keep animals, make cheese, preserve fruits and vegetables, gather eggs and honey, make sausage, and much more—the how-to is all here for the enterprising homesteader.

■ 487,000 COPIES IN PRINT

Paper; 368 pages; 7 x 9
Two-color
\$18.99 US
ISBN 978-1-60342-138-6



“The perfect tool for establishing and maintaining a productive, sustainable homestead and landscape.”

—John Mesko, executive director of the Midwest Organic & Sustainable Education Service (MOSES)

The Backyard Homestead Seasonal Planner

ANN LARKIN HANSEN

From midwinter soil preparation to early-summer haying, efficiently juggling a multitude of tasks is crucial to a farm’s success. This is the essential companion for farmers looking for expert advice on what to do and when to do it. Every critical turn of the year features an at-a-glance to-do list, along with tips and more in-depth exploration of key topics for the season.

■ 90,000 COPIES IN PRINT

Paper w/partially concealed wire-o; 208 pages; 7 x 9
Two-color
\$18.95 US
ISBN 978-1-61212-697-5



“If it isn't in this book, you don't need to know it.”

—Ed Smith, author of *The Vegetable Gardener's Bible*

The Backyard Homestead Guide to Growing Organic Food

TANYA DENCKLA COBB

This essential guide to growing a bountiful food garden includes detailed seed-starting, growing, and harvesting information for 62 vegetables, fruits, and herbs, a complete companion-planting guide, and organic pest-control handbook. Author Tanya Denckla Cobb presents key information including when to start seeds for each type of crop, how far apart to space seedlings, how to tell when a crop is ready to harvest, and notes on preservation.

Paper; 328 pages; 7 x 9
Illustrations throughout
\$24.99 US
ISBN 978-1-63586-790-9

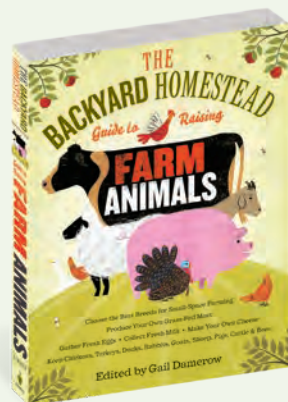

The Backyard Homestead Guide to Raising Farm Animals

EDITED BY GAIL DAMEROW

Enjoy a weekend breakfast featuring eggs, bacon, and honey from your own chickens, pigs, and bees, or a holiday meal with your own heritage-breed turkey as the main attraction. Gail Damerow covers everything you need to successfully raise your own farm animals. Even with just a small plot of land, you can become more self-sufficient, save money, and enjoy healthy, delicious animal products.

■ 105,000 COPIES IN PRINT

Paper; 360 pages; 8½ x 10½
Two-color with 8-page full-color fold-out insert
\$24.95 US
ISBN 978-1-60342-969-6



The Backyard Homestead Book of Building Projects

SPIKE CARLSEN

With simple, step-by-step instructions that even novices can use, this book of 76 projects is the go-to resource for anyone building DIY functional structures and essential pieces of equipment for house and garden, yard, and root cellar.

■ 55,000 COPIES IN PRINT

Paper; 296 pages; 8½ x 10½
Two-color with 8-page color insert
\$26.99 US
ISBN 978-1-61212-085-0



The Backyard Homestead Book of Kitchen Know-How

ANDREA CHESMAN

From milling flour to curing sausage, freezing or drying vegetables to preserving fruits, this go-to handbook teaches everything farm-fresh food enthusiasts need to know.

Paper; 368 pages; 7 x 9
Two-color
\$21.99 US
ISBN 978-1-61212-204-5



Worms Eat My Garbage, 35th Anniversary Edition

MARY APPELHOF & JOANNE OLSZEWSKI

This best-selling guide to the practice of vermicomposting (using worms to recycle food waste into nutrient-rich fertilizer for houseplants or gardens) features up-to-date information on the entire process, from building or purchasing a worm bin to maintaining the worms and harvesting the finished compost.

Paper; 192 pages; 6 x 9
Illustrations throughout
\$15.99 US
ISBN 978-1-61212-947-1

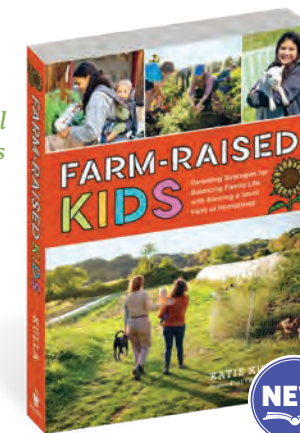

“A beautiful book full of real-life examples that will benefit the next generation of farmers and homesteaders.”

—Josh Volk, author of *Compact Farms* and *Build Your Own Farm Tools*

Farm-Raised Kids

KATIE KULLA

Author Katie Kulla offers her own hard-won wisdom, gleaned from more than a decade of raising kids while running a CSA farm with her husband. The book features invaluable advice and insights from other farmer-parents and a wealth of practical tips and ideas for how to engage children on the farm—including activities for learning and play, and suggestions for how to enlist kids in chores and other farm responsibilities.

Paper; 240 pages; 6 x 8
Full-color
\$24.99 US
ISBN 978-1-63586-671-1



One-Woman Farm

JENNA WOGINRICH

Beginning and ending in October—the conclusion of a successful growing season and the start of a long, reflective winter—these seasonal writings reveal the daily surprises and moments of pure grace that fill a farm year.

Hardcover with jacket; 208 pages; 6 x 7
Two-color
\$16.95 US
ISBN 978-1-60342-718-0

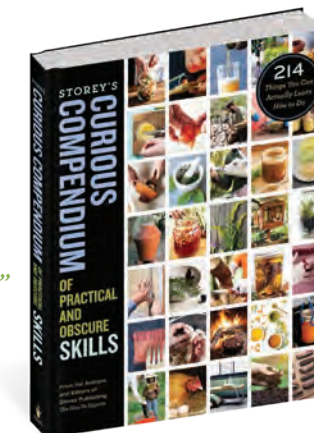

“The perfect book to spark a new interest or passion and have a lot of fun along the way.”

—Booklist starred review

Storey's Curious Compendium of Practical and Obscure Skills

Readers with a hunger for knowledge and an interest in the myriad ways people have taught themselves to make, grow, and build will discover the ins and outs of how to do everything they've ever wondered about in this colorful, inviting volume. With dozens of useful and intriguing visual tutorials that cover how to carve a turkey, capture a swarm of bees, predict the weather by the clouds, darn socks, create a butterfly garden, set up a dog agility course, keep a nature sketchbook, navigate by the stars, and more, this rich compendium will educate, fascinate, spark conversation, and inspire new hobbies and experiences.

Hardcover; 344 pages; 9½ x 11½
Full-color
\$29.95 US
ISBN 978-1-63586-191-4

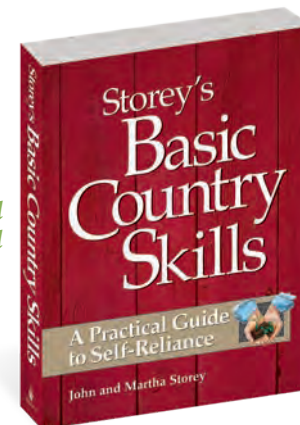

“[This book is] like having a whole community of seasoned gardeners, farmers, and homesteaders living next door to you.”

—New York Times

Storey's Basic Country Skills

JOHN & MARTHA STOREY

For anyone who wants to be more self-sufficient, more than 150 of Storey's expert authors share their knowledge of gardening, homesteading, building, animal husbandry, and more. This guide shows how to milk a cow, sharpen an axe, preserve fruits and vegetables, clean a chimney, and grow raspberries.

■ 197,000 COPIES IN PRINT

Paper; 576 pages; 8½ x 11
Two-color
\$24.99 US
ISBN 978-1-58017-202-8

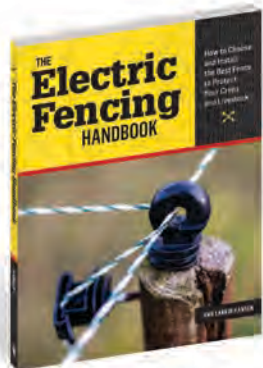

"Easy-to-follow instructions, regardless of whether you want to keep livestock in or wild animals out."
—Richard Banks, editorial director of FarmLife

The Electric Fencing Handbook

ANN LARKIN HANSEN
Farmers, ranchers, beekeepers, and gardeners will learn how to use electric fencing effectively to keep certain animals away while preventing others from getting out. The three most popular kinds of electric fencing are covered, with descriptions of when each kind should be used and how to incorporate it into rotational grazing.
Paper; 96 pages; 7 x 9
Full-color
\$14.95 US
ISBN 978-1-61212-891-7

FIT THE FENCE



RATION A PASTURE BY STRIP GRAZING

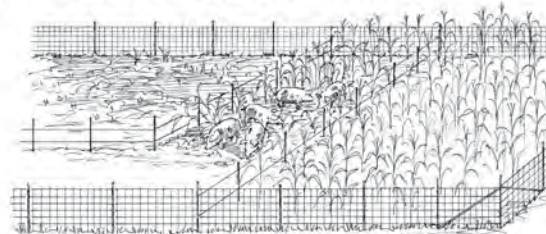

BUILD A PADDOCK SYSTEM

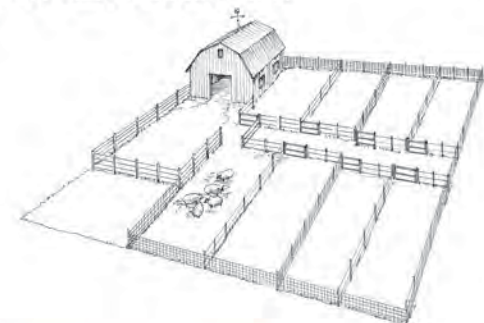

Managing Manure
MARK KOPECKY
Using manure to replenish soil is economical and easy! This book discusses the characteristics and nutrient content of various types of manure and describes the practices necessary to store and spread manure safely and effectively, including on organic farms.
Paper; 112 pages; 5 x 7
Illustrations throughout
\$9.95 US
ISBN 978-1-61212-458-2



Making Hay
ANN LARKIN HANSEN
Making hay is a profitable enterprise for farmers and livestock owners with extra land. This book details the five steps of haymaking, as well as the equipment it requires, which types of grass make the best hay, and how to improve a field.
Paper; 96 pages; 5 x 7
Illustrations throughout
\$9.95 US
ISBN 978-1-61212-367-7

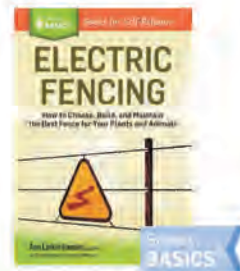

Electric Fencing
ANN LARKIN HANSEN
Electric fencing is an essential tool for successful rotational grazing and the protection of livestock and plantings from predators. Here, electric fencing is explained in everyday terms, with information on how to choose, install, and maintain systems that best suit farmers' needs.
Paper; 96 pages; 5 x 7
Illustrations throughout
\$9.95 US
ISBN 978-1-61212-143-7



Finding Good Farmland
ANN LARKIN HANSEN
Purchasing the perfect plot for a new small-scale farming enterprise requires careful consideration of many elements. From where to look for good farmland to financing the purchase and every step in between, this book is the essential guide to making it happen.
Paper; 128 pages; 5 x 7
Illustrations throughout
\$9.95 US
ISBN 978-1-61212-086-7



Maintaining Small-Farm Equipment
STEVE & ANN LARKIN HANSEN
This practical guide to proper maintenance and performance of minor repairs on mowers, trimmers, ATVs, plows, discs, planters, cultivators, balers, tractors, and more ensures that new and inexperienced farmers can keep equipment that's essential for small-farm success running smoothly.
Paper; 112 pages; 5 x 7
Illustrations throughout
\$9.95 US
ISBN 978-1-61212-527-5



Growing Christmas Trees
PATRICK WHITE & LEWIS HILL
In this invaluable resource, landowners who want to grow and sell Christmas trees will learn how to choose the best site and tree species, prepare the soil, plant and nurture trees to market size, and generate additional income with wreaths and greens.
Paper; 128 pages; 5 x 7
Illustrations throughout
\$9.95 US
ISBN 978-1-61212-365-3

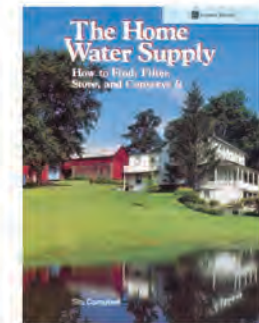

The Home Water Supply
STU CAMPBELL
This comprehensive handbook offers homeowners down-to-earth, money-saving solutions to every water-related problem they have had or are likely to have, including locating water on their property, and how to purify, store, and distribute it throughout the home.
62,000 COPIES IN PRINT
Paper; 240 pages; 8½ x 11
Photographs and illustrations throughout
\$19.95 US
ISBN 978-0-88266-324-1



How to Build Your Own Greenhouse
ROGER MARSHALL
Unlock new growing opportunities and increase your property value with an outdoor conservatory. In this illustrated guide, Roger Marshall shows you how to build your own greenhouse using simple, easy-to-follow techniques. Covering everything from selecting a site to glazing glass, Marshall includes tips on laying a foundation, construction materials, ventilation, and much more. Whether your goal is to stretch the growing season or create a lush space for a year-round hot tub, you can build the greenhouse of your dreams.
46,000 COPIES IN PRINT
Paper; 264 pages; 8½ x 10½
Illustrations throughout
\$24.95 US
ISBN 978-1-58017-647-7



The Water-Wise Home
LAURA ALLEN
Water is becoming increasingly precious around the world, yet the average American family uses approximately 400 gallons a day. This illustrated manual teaches homeowners how to lower their water bills, save water through conservation techniques and systems, and create a water-wise landscape. It is filled with solutions and detailed illustrated instructions for projects, such as a rooftop catchment system, a composting toilet, and a branched drain system.
Silver Nautilus Award
Paper; 256 pages; 8½ x 10½
Illustrations throughout
\$24.95 US
ISBN 978-1-61212-169-7

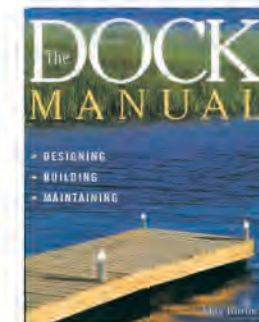

The Dock Manual
MAX BURNS
Add value and enjoyment to your waterfront property by building your own dock. From analyzing your shoreline and choosing an appropriate design to accessorizing with decorative trims, Max Burns covers every aspect of dock construction. Providing illustrated step-by-step instructions with complete materials and tools lists for 10 distinct docks, Burns also offers expert advice on different types of ramps and winterizing techniques. Encouraging you to get out on the water, this guide will inspire you create the dock of your dreams.
51,000 COPIES IN PRINT
Paper; 208 pages; 8½ x 11
Two-color
\$24.95 US
ISBN 978-1-58017-098-7

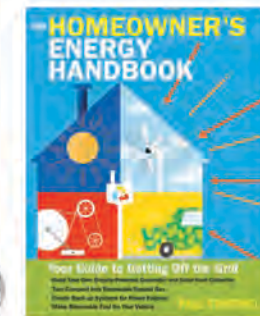

The Homeowner's Energy Handbook
PAUL SCHECKEL
Clear explanations of the fundamentals of solar, wind, and biofuel energy production help readers prepare their homes for renewables. This book features illustrated step-by-step instructions for building energy-saving—and energy-producing—equipment that can help homeowners reduce their energy use or take their home entirely off the grid.
Paper; 288 pages; 8½ x 10½
Two-color
\$24.95 US
ISBN 978-1-61212-016-4



Install Your Own Solar Panels
JOSEPH BURDICK & PHILIP SCHMIDT
These user-friendly instructions and step-by-step photos can save homeowners thousands of dollars in solar panel installation costs. From assembling rooftop racking or building a ground-mount structure to setting up the electrical connections and making a battery bank for off-grid systems, this detailed manual follows the same process professional contractors use.
Paper; 200 pages; 8 x 10
Full-color
\$19.99 US
ISBN 978-1-61212-825-2

"Burdick and Schmidt help anyone interested in solar power to do it themselves."
—Dan Fink, professor in solar energy technology, Ecotech Institute

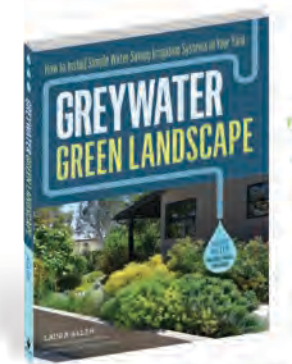

Greywater, Green Landscape
LAURA ALLEN
Keep your lawn and garden lush without wasting resources by capturing and recycling the greywater that drains from your sink, shower, and washing machine. This accessible and detailed guide walks you through each step of planning for and installing a variety of greywater systems, including laundry-to-landscape and branched drain gravity-fed systems. After identifying greywater sources in your home and estimating flow rate, you'll learn to pinpoint where to redirect the wastewater for the greatest benefit. No matter which system you decide to build, you'll have the information to construct it yourself or move forward with confidence to hire a professional.
Paper; 200 pages; 7 x 9
Full-color
\$16.95 US
ISBN 978-1-61212-839-9

"Simple, affordable projects and strategies to conserve water and reuse it."
—Gemma Bulos, director of Global Women's Water Initiative

BEST-SELLING AUTHOR DEREK “DEEK” DIEDRICKSEN

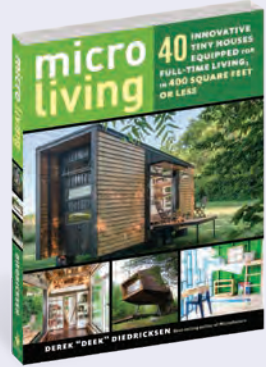

“Packed with engaging illustrations, gorgeous photographs, precise blueprints, and pragmatic advice for anyone working on their tiny home dream.”

—The Minimalists

Micro Living

Get an insider’s perspective on what tiny house life is really like, with profiles of 40 houses equipped for full-time living in 400 square feet or less. Detailed photography and a floor plan for each structure highlight inventive space-saving design features along with the nuts and bolts of heating, cooling, electric, and plumbing systems. The real-life stories of residents impart the pleasures and challenges of day-to-day living. With tips on what to consider before building, along with framing plans for a prototype small cabin, this book is the perfect starter guide for both dreamers and doers.

Paper; 256 pages; 7 x 9
Full-color
\$18.95 US
ISBN 978-1-61212-876-4

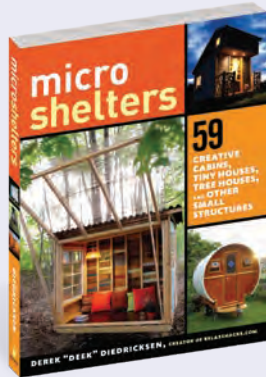

“Diedricksen zeroes in on the DIY art of small living.”

—Dwell

“Microshelters supports both dreamers and designers, and nearly every budget, aesthetic, and skill. Cheers and a big thank you to Deek!”

—Dee Williams, author of *The Big Tiny*

Microshelters

People looking to downsize their lives—or just create their own backyard (or backwoods) getaway—will enjoy this photographic survey of unique and inspiring cabins, tree houses, studios, and tiny houses that has been gathered from the foremost designers and bloggers in the field. The builder itching to get started will love the six plan sets, as well as tips on using recycled materials and advice on fun ways to add low-budget personal touches to any homemade shelter.

■ **101,000 COPIES IN PRINT**

Paper; 256 pages; 7 x 9
Full-color
\$18.95 US
ISBN 978-1-61212-353-0

BEST-SELLING AUTHOR GERALD ROWAN



“This is one neat book . . . Besides having 62 unique designs that will inspire you, it is full of useful construction information.”

—Kent Griswold, Tiny House Blog

Compact Cabins

In the woods, on a mountaintop, or at the water’s edge, a small cabin can fulfill big dreams. With attention to efficient living and minimizing energy footprints, Gerald Rowan provides 62 designs for compact and creative buildings that are flexible enough to fit whatever your needs may be. Rowan includes detailed floor plans with plenty of modular elements that make the designs adaptable and easy to recreate with cost-effective, low-maintenance materials. Make the most of the cabin you call home, regardless of its size.

■ **225,000 COPIES IN PRINT**

Paper; 216 pages; 8 x 9 3/16
Two-color
\$19.99 US
ISBN 978-1-60342-462-2

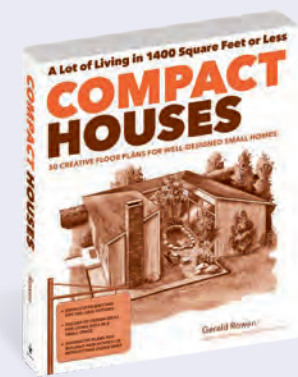

“A great book with wonderful designs for smaller homes. Just the inspiration you need to find the right design for a small home for your future needs..”

—Kent Griswold, Tiny House Blog

Compact Houses

Discover the huge possibilities of a small house! Whether you’re building from scratch or retrofitting an existing structure, these 50 innovative floor plans will show you how to make the most of houses measuring 1,400 square feet or less. Gerald Rowan presents creative and efficient layouts that use every inch of space, with tips on fully maximizing closets, porches, bathrooms, attics, and basements. From reorganizing a small storage area to building a brand-new home, you’ll find a detailed design to fit your family’s needs.

Paper; 208 pages; 8 x 9 3/16
Two-color
\$19.99 US
ISBN 978-1-61212-102-4



Guerilla Furniture Design

WILL HOLMAN

Today’s DIY “maker” culture meets the guerilla approach to life, resulting in handcrafted furnishings from found and sustainable materials. Featuring 31 step-by-step projects using reclaimed paper, wood, plastic, and metal, these clever, modern designs are functional, easy to assemble, economical, and simple to break down and move—perfect for apartment dwellers and homeowners on a budget.

Paper; 192 pages; 8 x 9 1/4
Full-color
\$19.95 US
ISBN 978-1-61212-303-5



HomeMade

KEN BRAREN & ROGER GRIFFITH

These 101 exciting projects for home and garden come with complete, easy-to-follow directions that will save time and money. Even readers with limited construction experience can follow the simple instructions and clear illustrations for a lawn chair, compost bin, movable shed, and more.

■ **108,000 COPIES IN PRINT**

Paper; 176 pages; 8 1/2 x 11
Illustrations throughout
\$14.95 US
ISBN 978-0-88266-103-2

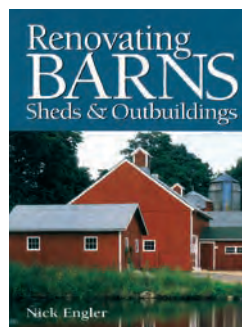

Renovating Barns, Sheds & Outbuildings

NICK ENGLER

Complete restoration techniques for frame, pole, post-and-beam, and masonry structures are covered, with step-by-step instructions on how to square and strengthen a barn’s structure, enlarge or modify the building, repair or replace the roofing and siding, install new windows and doors, and even add electricity and plumbing.

Paper; 256 pages; 8 1/2 x 11
Photographs and illustrations throughout
\$24.95 US
ISBN 978-1-58017-216-5

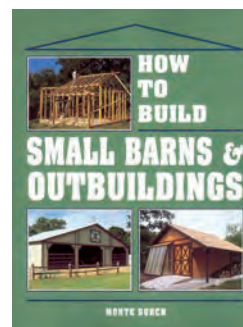

How to Build Small Barns & Outbuildings

MONTE BURCH

This collection of more than 20 projects offers complete plans and instructions for building a wide range of structures designed for adaptability and usefulness. Readers will learn the step-by-step fundamentals of general construction, from planning and laying out a site to do-it-yourself framing, roofing, wiring, and plumbing.

■ **171,000 COPIES IN PRINT**

Paper; 288 pages; 8 1/2 x 11
Photographs and illustrations throughout
\$19.95 US
ISBN 978-0-88266-773-7



The Classic Hewn-Log House

CHARLES McRAVEN

From hewing the first log to laying the last chimney stone, this guide covers every aspect of hewn-log construction and restoration. Clear, how-to line illustrations accompany the text throughout, and a full-color gallery shows finished structures. Readers will be inspired by these durable, inviting homes.

Paper; 208 pages; 8 1/2 x 10 1/8
One-color with 16-page full-color insert
\$24.99 US
ISBN 978-1-58017-590-6



Skoolie!

WILL SUTHERLAND

School buses made into mobile living spaces—known as skoolies—are a natural extension of the tiny house craze. Experienced builder Will Sutherland profiles eight fellow skoolie fans and their vehicles, and offers a complete, step-by-step guide to the conversion process, from seat removal to planning layout and installing insulation, flooring, and furnishings.

Hardcover; 208 pages; 10 1/2 x 8
Full-color
\$24.95 US
ISBN 978-1-63586-072-6



Building Small Barns, Sheds & Shelters

MONTE BURCH

Work, living, and storage areas can be expanded with these easy-to-follow plans and construction methods for low-cost barns, sheds, and animal shelters.

■ **337,000 COPIES IN PRINT**

Paper; 248 pages; 8 1/2 x 11
Photographs and illustrations throughout
\$19.99 US
ISBN 978-0-88266-245-9

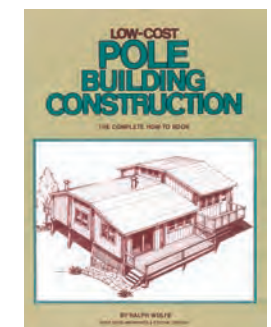

Low-Cost Pole Building Construction

RALPH WOLFE

This definitive how-to book will save money, labor, and time in building a small home, barn, or other structure.

■ **315,000 COPIES IN PRINT**

Paper; 192 pages; 8 1/2 x 11
Photographs and illustrations throughout
\$19.99 US
ISBN 978-0-88266-170-4

BEST-SELLING AUTHOR JACK A. SOBON

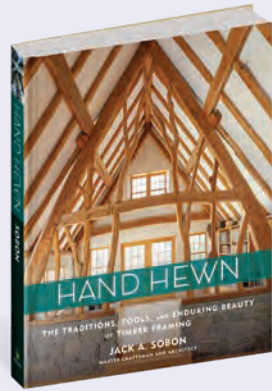

“Sobon has spent his career turning trees into magnificent structural frameworks for buildings that satisfy our yearning for real strength, warmth, and honesty.”

—Max Jacobson, coauthor of *A Pattern Language*

Hand Hewn

In this fascinating exploration of the traditions and artistry of timber framing, internationally renowned timber-frame architect and builder Jack A. Sobon explains how the organic forms of trees become the framework for a home. Inspiring photos of Sobon's original designs and profiles of the classic tools he uses to hand hew each timber make this an insightful and compelling tribute to the craft.

Hardcover with jacket; 272 pages; 9 x 11½
Full-color
\$37.00 US
ISBN 978-1-63586-000-9



Build a Classic Timber-Framed House

With the step-by-step instructions in this book, readers can build a classic timber-framed house that is enduring and features a level of craftsmanship rare in modern construction.

Paper; 208 pages; 8½ x 11
Photographs and illustrations throughout
\$24.99 US
ISBN 978-0-88266-841-3

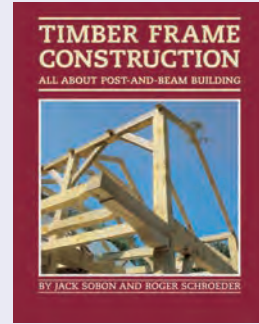

Timber Frame Construction

JACK SOBON & ROGER SCHROEDER
With dozens of illustrations and photos, here is a practical how-to for anyone who wants to try this method of building. It offers the basics of timber framing, how to design for strength and beauty, and how to use modern tools and time-tested methods.

■ **136,000 COPIES IN PRINT**
Paper; 208 pages; 8½ x 11
Photographs and illustrations throughout
\$19.99 US
ISBN 978-0-88266-365-4

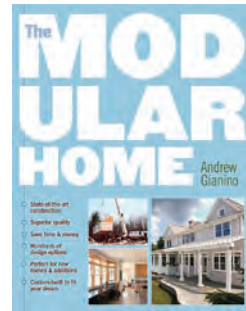

The Modular Home

ANDREW GIANINO
This comprehensive handbook for prospective modular home buyers explains every detail of buying and building a modular home—or a modular addition to an existing home.

Paper; 336 pages; 8½ x 10½
One-color with 16-page full-color insert
\$24.95 US
ISBN 978-1-58017-526-5



A racing axe in the hands of an accomplished chopper can cut several inches of wood with a single blow.



“Part ode, part how-to guide, American Axe is a fascinating look at the essential tool.”

—*Popular Mechanics*

“Even if you already live with an axe in your hands, Brett’s deep appreciation of our essential companion will bring you closer to it.”

—Roy Underhill, host of PBS’s *The Woodwright’s Shop*

American Axe

BRETT MCLEOD

From hand-forged axes of the Viking conquests to the American homesteader’s felling axe, this is a tool that has shaped human history like few others. *American Axe* pays tribute to this iconic instrument of settlement and industry, with rich history, stunning photography, and profiles of the most collectible vintage axes such as *The Woodslasher*, *Keen Cutter*, and *True Temper Perfect*. Combining his experiences as a forester, axe collector, and former competitive lumberjack, author Brett McLeod conveys the allure of this deceptively simple woodcutting implement and celebrates the resurging interest in its story and use.

■ **2021 POPULAR MECHANICS TOOL AWARD**

Hardcover; 192 pages; 7 x 11
Full-color
\$24.95 US
ISBN 978-1-63586-139-6

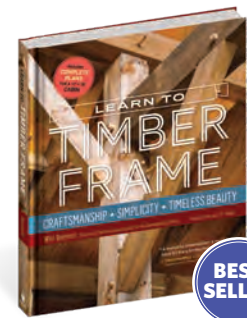
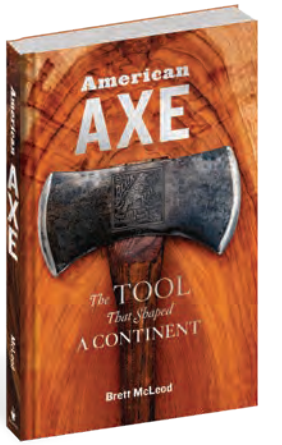

“Opens the world of timber framing to anyone wishing to invest good labor to make something beautiful, useful, and enduring.”

—Tedd Benson, author of *Timberframe* and founder of Bensonwood and Unity Homes

WILL BEEMER

Expert Will Beemer takes you through the entire process from start to finish, beginning with timber sourcing and ending with a finished building. Using full-color photos, detailed drawings, and clear step-by-step instructions, Beemer shows you exactly how to build one small (12' x 16') timber-frame structure — suitable for use as a cabin, workshop, or studio. He also explains how to modify the structure to suit your needs and location by adding a loft, moving doors or windows, changing the roof pitch, or making the frame larger or smaller. You'll end up with a beautiful building as well as solid timber-framing skills that you can use for a lifetime.

■ **77,000 COPIES IN PRINT**

Hardcover; 192 pages; 8 x 9½
Full-color
\$25.00 US
ISBN 978-1-61212-668-5

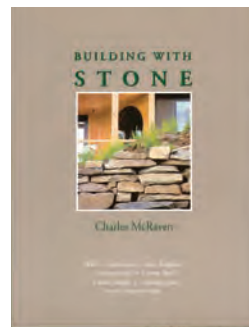

Building with Stone

CHARLES McRAVEN

Anyone can learn the art and craft of creating stone structures with these easy-to-follow building instructions for walls, dams, bridges, and more. Extolling the benefits of careful craftsmanship, this accessible handbook inspires readers to create works of enduring beauty with simple materials, honest labor, and concentrated patience.

■ **119,000 COPIES IN PRINT**

Paper; 192 pages; 8½ x 11
Photographs and illustrations throughout
\$17.95 US
ISBN 978-0-88266-550-4



Be Your Own House Contractor

CARL HELDMANN

With this book as a guide, anyone who can balance a checkbook and deal fairly with people can manage every stage of a construction project, from finding and buying land to securing financing, setting a budget and schedule, and hiring subcontractors to do the building.

Paper; 176 pages; 6 x 9
One-color with 14-page photo gallery
\$18.99 US
ISBN 978-1-58017-840-2



Build Your Own Low-Cost Log Home

ROGER HARD

This is the essential book for the log-house builder, with special tips that come only with experience. It covers how manufacturers' kits differ, how to pick the best site, and how to know when to hire help.

Paper; 200 pages; 8½ x 11
Photographs and illustrations throughout
\$19.95 US
ISBN 978-0-88266-399-9

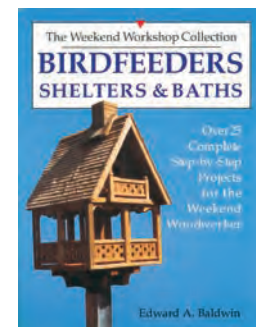

Birdfeeders, Shelters & Baths

EDWARD A. BALDWIN

Readers will find more than 25 creative designs for birdfeeders, birdbaths, and other structures, along with tips for controlling squirrels and other predators while attracting birds to the backyard. Step-by-step illustrations make these unique projects accessible to all bird lovers.

■ **144,000 COPIES IN PRINT**

Paper; 128 pages; 8½ x 11
One-color with 8-page color photographic insert
\$16.95 US
ISBN 978-0-88266-623-5

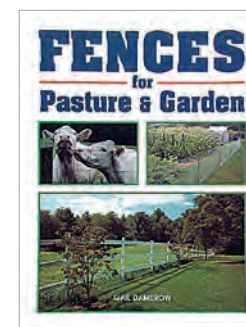

Fences for Pasture & Garden

GAIL DAMEROW

Filled with sound, up-to-date advice and instruction, this complete guide makes fence building a task anyone can tackle with confidence.

■ **55,000 COPIES IN PRINT**

Paper; 160 pages; 8½ x 11
Illustrations throughout
\$16.95 US
ISBN 978-0-88266-753-9

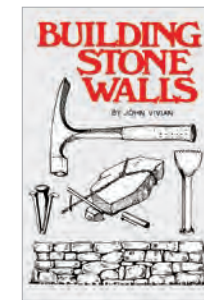

Building Stone Walls

JOHN VIVIAN

With a pile of rocks, a few tools, and this book full of techniques, plans, illustrations, and photographs, anyone can build a beautiful, enduring stone wall. Lively, step-by-step instructions will help readers overcome challenges such as poor drainage, sloping ground, and low-quality rubble material so they can create customized landscape features with gates, retaining walls, or stiles.

■ **134,000 COPIES IN PRINT**

Paper; 112 pages; 6 x 9
Photographs and illustrations throughout
\$14.99 US
ISBN 978-0-88266-074-5

“A treasure trove of great and useful building ideas for homeowners to implement in their backyards. The detailed and precise drawings leave very little to question.”

—Dean Johnson, Host and Executive Producer, *Hometime*

The Backyard Homestead Book of Building Projects

SPIKE CARLSEN

Expert woodworker Spike Carlsen offers simple, fully illustrated instructions for 76 projects that homesteaders, gardeners, and outdoor enthusiasts can build themselves. From plant supports and clotheslines to a greenhouse, and a root cellar with storage bins, most of the projects are suitable for complete novices, and all use just basic tools and easy-to-find materials. You'll find techniques to build whatever your outdoor world is missing, with additional tips to live sustainably.

Paper; 296 pages; 8½ x 10½
Two-color with 8-page color insert
\$26.99 US
ISBN 978-1-61212-085-0



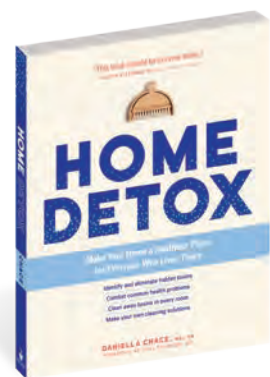

Home Detox

DANIELLA CHACE, MSc, CN

From the bedroom mattress and pillows to daily cleaning products for the kitchen and bath, toothbrushes, and even furniture and clothing, toxins are embedded in many products and items used regularly in the home—and they are making us sick. *Home Detox* is a practical, accessible guide to understanding the problem and how we can address it in our own homes in a manageable and affordable way. Daniella Chace, a professional toxicologist and health writer, teaches readers how to identify potential toxins, with an easy-to-follow, room-by-room evaluation of the “Toxic Ten” in each space. She explains the connection between toxins in everyday objects and chronic health issues such as headaches, asthma, high cholesterol, skin problems, and sleep problems and offers strategies for eliminating toxins, along with easy recipes for effective homemade cleaning solutions using essential oils, baking soda, vinegar, and other ingredients that are natural, affordable, and effective.

Paper; 208 pages; 7 x 9
Full-color
\$19.99 US
ISBN 978-1-63586-390-1

Make Your Home a Healthier Place for Everyone Who Lives There



Room-by-room guide to green cleaning for a healthier lifestyle.



Easy recipes for homemade cleaning solutions that are effective and affordable.



“This book supplies the practical advice we need to keep our homes safe. A guide for taking control of our health that addresses the hidden toxins in our homes.”

—from the foreword by Joel Fuhrman, MD,
#1 *New York Times* best-selling author of *Eat to Live*



Prepping 101

KATHY HARRISON

The next severe storm, power outage, or financial meltdown could hit at any time, and having a household contingency plan could mean the difference between life and death. In this highly accessible preparedness guide, critical information is presented in 40 doable steps that families and communities can take to ensure survival in the next short- or long-term emergency.

Paper; 176 pages; 7½ x 9¼
Full-color
\$16.95 US
ISBN 978-1-61212-957-0

“With Kathy Harrison’s reassuring help and thoughtful guidance, you can do this—and keep your loved ones safe and well.”

—Sharon Astyk, author of *Making Home: Adapting Our Homes and Lives to Settle in Place*

- **A practical, step-by-step preparedness program** suitable for every household
- **Teaches 40 essential steps to take and skills to learn**, including how to safely store and ration food, water, fuel, and more
- **Essential information for riding out weather emergencies and natural disasters**, which occur year-round and in every geographic region

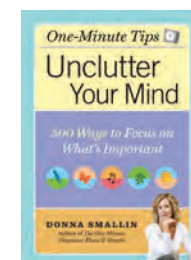
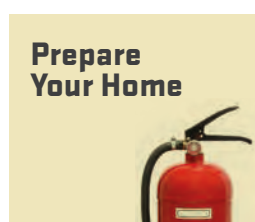

Unclutter Your Mind

DONNA SMALLIN

Readers learn to stay focused on their goals, develop strong relationships, and achieve emotional fulfillment with these 500 simple strategies and creative ideas for clearing away unnecessary worries, daily stresses, and unproductive habits.

■ **56,000 COPIES IN PRINT**

Paper; 288 pages; 5 x 7
Two-color
\$10.95 US
ISBN 978-1-58017-636-1



Clear the Clutter, Find Happiness

DONNA SMALLIN

This fresh set of one-minute tips is designed to inspire regular routines that minimize the amount of time spent on decluttering and cleaning, from making closet organization manageable to making a daily habit of cleaning the bathroom sink.

Paper; 288 pages; 4 x 6
Two-color
\$10.95 US
ISBN 978-1-61212-351-6

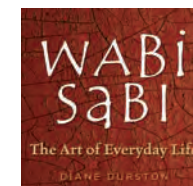

Wabi Sabi

DIANE DURSTON

The centuries-old Japanese concept of wabi sabi celebrates the beauty of simplicity, impermanence, and imperfection. This collection of profound insights and reflections for discovering the essence of wabi sabi is presented in an irresistible hold-in-the-hand package and is sure to inspire anyone seeking humble beauty in daily life.

■ **54,000 COPIES IN PRINT**

Paper; 384 pages; 4¼ x 4¼
Two-color
\$9.99 US
ISBN 978-1-58017-628-6



Just in Case

KATHY HARRISON

This indispensable guide offers detailed instructions for setting up a simple home system that will allow any household to survive comfortably for several days without outside services. Included are ideas for food storage, alternative heating sources, toiletries and clothing, pet supplies, emergency communication plans, and more.

■ **71,000 COPIES IN PRINT**

Paper; 240 pages; 7¼ x 9¼
Two-color
\$18.95 US
ISBN 978-1-60342-035-8



Feng Shui Dos & Taboos

ANGI MA WONG

This fun, A-to-Z format offers more than 350 feng shui practices, principles, and tips that will help readers improve their career, relationships, health, and prosperity.

■ **372,000 COPIES IN PRINT**

Paper; 416 pages; 4¼ x 4¼
Two-color
\$8.95 US
ISBN 978-1-58017-308-7



Naturally Bug-Free

STEPHANIE L. TOURLES

Nontoxic alternatives to chemical-laden insecticides are easy to make. These 75 all-natural recipes for balms, oils, tinctures, pet shampoos, flea collars, and powders work to safely and effectively repel biting insects as well as mice and other household vermin.

Paper; 176 pages; 5 x 7
Two-color
\$10.99 US
ISBN 978-1-61212-596-1

BEST SELLER

“Ashley Cantley’s modernized, customizable approach to Feng Shui makes it fun and easy to transform your space and your life.”

—Heather Askinosie,
cofounder of Energy Muse



High-Vibe Feng Shui

ASHLEY CANTLEY

Blending the traditional and the modern, this guide makes the ancient Chinese practice of feng shui accessible to a new generation. Its practical, customizable 11-step approach features guided exercises that help readers create intention and transform energy flow for balance, groundedness, prosperity, and wellness.

Paper; 192 pages; 6 x 8
Two-color
\$16.95 US
ISBN 978-1-63586-238-6

“A gem of a book! Useful, educational, and entertaining. Highly recommended!”

—Stephanie Tourles, author of the bestseller *Organic Body Care Recipes*



The Naturally Clean Home, 3rd Edition

KARYN SIEGEL-MAIER

In this updated edition of her best-selling book, Karyn Siegel-Maier brings together the formulas for home cleaning solutions that readers have trusted for years with new information and ingredients updated to today’s green standards. Along with a new focus on the antiseptic properties of essential oils, there are new recipes to create easy-to-make, nontoxic, environmentally friendly substitutes for popular cleaning products, including molded laundry and dishwasher tablets.

Paper; 224 pages; 5 x 7
Two-color
\$14.99 US
ISBN 978-1-63586-379-6

These information-packed mini-books focus on hundreds of traditional country skills. When a book covers too much and the Internet doesn't deliver reliable information, there's a bulletin to help you find it, fix it, make it, grow it, use it, or build it. Attractively packaged and priced, each **Country Wisdom Bulletin** features 32 pages of concise information on a single subject.

Country Wisdom Bulletins

- ▶ 32 pages
- ▶ Single-subject specific
- ▶ 5½ x 8½



ISBN 978-1-58017-784-9

FREE COUNTERTOP DISPLAY with the purchase of 48 Country Wisdom Bulletins

- Country Wisdom Countertop Display Holds 48 Country Wisdom Bulletins**
- ▶ Free with the purchase of 48 bulletins
 - ▶ 4-pocket display
 - ▶ Corrugated



67086	15 Herbs for Tea (A-184)	978-1-58017-086-4
66225	Baking with Sourdough (A-50)	978-0-88266-225-1
67219	Basic Bread Baking (A-198)	978-1-58017-219-6
67481	Cooking with Cranberries (A-281)	978-1-58017-481-7
66291	Cooking with Dried Beans (A-77)	978-0-88266-291-6
67269	Cooking with Edible Flowers (A-223)	978-1-58017-269-1
66276	Cooking with Honey (A-62)	978-0-88266-276-3
66326	Cooking with Yogurt (A-86)	978-0-88266-326-5
66231	Easy Game Cookery (A-56)	978-0-88266-231-2
66334	Favorite Pickles & Relishes (A-91)	978-0-88266-334-0
67218	Food Drying Techniques (A-197)	978-1-58017-218-9
66655	Great Rhubarb Recipes (A-123)	978-0-88266-655-6
66275	Grow 15 Herbs for the Kitchen (A-61)	978-0-88266-275-6
67274	Growing & Using Chives (A-225)	978-1-58017-274-5
67021	Growing & Using Cilantro (A-181)	978-1-58017-021-5
67085	Growing and Using Garlic (A-183)	978-1-58017-085-7

66607	Growing & Using Rosemary (A-161)	978-0-88266-607-5
67236	Growing & Using Tarragon (A-195)	978-1-58017-236-3
67267	Herbal Teas for Lifelong Health (A-220)	978-1-58017-267-7
67880	Jams, Jellies & More (A-282)	978-1-58017-880-8
66556	Making & Using Flavored Vinegars (A-112)	978-0-88266-556-6
67879	Making Cheese, Butter & Yogurt (A-283)	978-1-58017-879-2
66998	Making European Breads (A-172)	978-0-88266-998-4
66289	Making Homemade Wine (A-75)	978-0-88266-289-3
66414	Making Ice Cream and Frozen Yogurt (A-142)	978-0-88266-414-9
66499	Making Liqueurs for Gifts (A-101)	978-0-88266-499-6
66760	Making Quick Breads (A-135)	978-0-88266-760-7
66222	Making the Best Apple Cider (A-47)	978-0-88266-222-0
66054	Perfect Grilled Meats (A-146)	978-0-88266-054-7
67321	Sensational Soy: Recipes for a Healthy Diet (A-249)	978-1-58017-321-6
66720	Tea and Teatime Recipes (A-174)	978-0-88266-720-1

*Bestsellers in Boldface



67225	All the Onions (A-204)	978-1-58017-225-7
66207	Berries, Rasp- & Black (A-33)	978-0-88266-207-7
66290	Build Your Own Underground Root Cellar (A-76)	978-0-88266-290-9
67350	Easy-Care Orchids (A-250)	978-1-58017-350-6

66213	Building & Using Cold Frames (A-39)	978-0-88266-213-8
66344	Container Gardening (A-151)	978-0-88266-344-9
66719	Controlling Garden Weeds (A-171)	978-0-88266-719-5
66350	Easy Composters You Can Build (A-139)	978-0-88266-350-0

*Bestsellers in Boldface

67338	Easy-Care Water Garden Plants (A-236)	978-1-58017-338-4
67224	Fertilizers for Free (A-203)	978-1-58017-224-0
66378	Gardening in Clay Soil (A-140)	978-0-88266-378-4
67226	Gardening to Attract Birds (A-205)	978-1-58017-226-4
66209	Grafting Fruit Trees (A-35)	978-0-88266-209-1
66228	Great Grapes (A-53)	978-0-88266-228-2
66275	Grow 15 Herbs for the Kitchen (A-61)	978-0-88266-275-6
66600	Grow a Butterfly Garden (A-114)	978-0-88266-600-6
66713	Grow a Hummingbird Garden (A-167)	978-0-88266-713-3
66285	Grow Super Salad Greens (A-71)	978-0-88266-285-5
66277	Grow the Best Asparagus (A-63)	978-0-88266-277-0
66329	Grow the Best Blueberries (A-89)	978-0-88266-329-6
66282	Grow the Best Corn (A-68)	978-0-88266-282-4
66302	Grow the Best Peppers (A-138)	978-0-88266-302-9
67158	Grow the Best Strawberries (A-190)	978-1-58017-158-8
67157	Grow the Best Tomatoes (A-189)	978-1-58017-157-1
67274	Growing & Using Chives (A-225)	978-1-58017-274-5

67021	Growing & Using Cilantro (A-181)	978-1-58017-021-5
67085	Growing and Using Garlic (A-183)	978-1-58017-085-7
67280	Ginkgo Biloba (A-231)	978-1-58017-280-6
66475	Growing & Using Lavender (A-155)	978-0-88266-475-0
66607	Growing & Using Rosemary (A-161)	978-0-88266-607-5
67236	Growing & Using Tarragon (A-195)	978-1-58017-236-3
67266	Growing Herbs for Cold & Flu Relief (A-219)	978-1-58017-266-0
67014	Growing Herbs in Containers (A-179)	978-1-58017-014-7
66602	Growing Miniature Roses (A-116)	978-0-88266-602-0
67223	Improving Your Soil (A-202)	978-1-58017-223-3
66539	Landscaping with Annuals (A-108)	978-0-88266-539-9
66189	Pest-Proofing Your Garden (A-15)	978-0-88266-189-6
67339	Planning & Planting a Moon Garden (A-234)	978-1-58017-339-1
66229	Pruning Trees, Shrubs & Vines (A-54)	978-0-88266-229-9
66519	Starting Seeds Indoors (A-104)	978-0-88266-519-1
66195	What Every Gardener Should Know about Earthworms (A-21)	978-0-88266-195-7
66176	Wide Row Planting (A-02)	978-0-88266-176-6

*Bestsellers in Boldface



66177	Braiding Rugs (A-03)	978-0-88266-177-3
66180	Building Simple Furniture (A-06)	978-0-88266-180-3
67264	Easy-to-Build Adirondack Furniture (A-216)	978-1-58017-264-6
67230	Easy-to-Build Bird Feeders (A-209)	978-1-58017-230-1
67229	Easy-to-Build Birdbaths (A-208)	978-1-58017-229-5
67233	Easy-to-Build Birdhouses (A-212)	978-1-58017-233-2
66610	Holiday Gifts from Nature (A-162)	978-0-88266-610-5
66704	Holiday Gifts from the Workshop (A-163)	978-0-88266-704-1
66631	Hooking Rugs (A-120)	978-0-88266-631-0
66696	Knitting Problem Solver, The (A-128)	978-0-88266-696-9

66696	Knitting Problem Solver, The (A-128)	978-0-88266-696-9
66487	Making Country-Style Curtains (A-98)	978-0-88266-487-3
67303	Making Herbal Hand Creams and Salves (A-256)	978-1-58017-303-2
67341	Making Holiday Wreaths (A-262)	978-1-58017-341-4
67220	Making Natural Milk Soap (A-199)	978-1-58017-220-2
67275	Making Your Own Incense (A-226)	978-1-58017-275-2
66512	Picture Framing (A-153)	978-0-88266-512-2
66551	Quilting Basics (A-109)	978-0-88266-551-1
66588	Weaving Country Baskets (A-159)	978-0-88266-588-7

*Bestsellers in Boldface



66335	Best Fences, The (A-92)	978-0-88266-335-7
66296	Build Rabbit Housing (A-82)	978-0-88266-296-1

67273	Building Chicken Coops (A-224)	978-1-58017-273-8
66191	Eggs and Chickens (A-17)	978-0-88266-191-9

*Bestsellers in Boldface



PETS

*Bestsellers in Boldface			
67347	10 Herbs for Happy, Healthy Cats (A-261)	978-1-58017-347-6	
67358	Boarding Your Dog (A-268)	978-1-58017-358-2	
67345	Breaking Your Cat's Bad Habits (A-257)	978-1-58017-345-2	
67318	Breaking Your Dog's Bad Habits (A-241)	978-1-58017-318-6	
67361	Building a Doghouse (A-269)	978-1-58017-361-2	
67300	Cat Toys (A-251)	978-1-58017-300-1	
67323	Homemade Treats for Happy, Healthy Dogs (A-258)	978-1-58017-323-0	
67362	Housebound Dogs (A-270)	978-1-58017-362-9	
67363	Keeping Your Indoor Cat Happy & Healthy (A-271)	978-1-58017-363-6	
66999	Raising a Healthy Guinea Pig (A-173)	978-0-88266-999-1	
67324	Raising a Healthy Rabbit (A-259)	978-1-58017-324-7	
67364	Teaching Your Cat Simple Tricks (A-272)	978-1-58017-364-3	



BIRDS & WILDLIFE

*Bestsellers in Boldface			
67018	Building Bat Houses (A-178)	978-1-58017-018-5	
67230	Easy-to-Build Bird Feeders (A-209)	978-1-58017-230-1	
67229	Easy-to-Build Birdbaths (A-208)	978-1-58017-229-5	
67233	Easy-to-Build Birdhouses (A-212)	978-1-58017-233-2	
67226	Gardening to Attract Birds (A-205)	978-1-58017-226-4	
66600	Grow a Butterfly Garden (A-114)	978-0-88266-600-6	
66713	Grow a Hummingbird Garden (A-167)	978-0-88266-713-3	
67231	Helping Orphaned or Injured Wild Birds (A-210)	978-1-58017-231-8	



DO-IT-YOURSELF

*Bestsellers in Boldface			
66335	Best Fences, The (A-92)	978-0-88266-335-7	
66193	Build a Pond for Food & Fun (A-19)	978-0-88266-193-3	
66295	Build a Smokehouse (A-81)	978-0-88266-295-4	
67138	Building Homebrew Equipment (A-186)	978-1-58017-138-0	
66180	Building Simple Furniture (A-06)	978-0-88266-180-3	
67265	Building Stone Walls (A-217)	978-1-58017-265-3	
66327	Cold Storage for Fruits & Vegetables (A-87)	978-0-88266-327-2	
66344	Container Gardening (A-151)	978-0-88266-344-9	
67264	Easy-to-Build Adirondack Furniture (A-216)	978-1-58017-264-6	
66226	Making Maple Syrup (A-51)	978-0-88266-226-8	
66229	Pruning Trees, Shrubs & Vines (A-54)	978-0-88266-229-9	
67198	What to Do When the Power Fails (A-191)	978-1-58017-198-4	



HEALTH & BEAUTY

*Bestsellers in Boldface			
67283	10 Essential Herbs for Lifelong Health (A-218)	978-1-58017-283-7	
67305	25 Aromatherapy Blends for De-Stressing (A-244)	978-1-58017-305-6	
67301	Aromatherapy Massage from Head to Toe (A-254)	978-1-58017-301-8	
67348	Flu Therapy: A Natural and Herbal Approach (A-266)	978-1-58017-348-3	
67280	Ginkgo Biloba (A-231)	978-1-58017-280-6	
67266	Growing Herbs for Cold & Flu Relief (A-219)	978-1-58017-266-0	
67277	Healing Herbal Wines, Vinegars & Syrups (A-228)	978-1-58017-277-6	
67267	Herbal Teas for Lifelong Health (A-220)	978-1-58017-267-7	
67268	Herbal Treatments for Healthy Hair (A-221)	978-1-58017-268-4	
67303	Making Herbal Hand Creams and Salves (A-256)	978-1-58017-303-2	
66716	Natural & Herbal Family Remedies (A-168)	978-0-88266-716-4	
67304	Natural & Herbal Remedies for Carpal Tunnel Syndrome (A-245)	978-1-58017-304-9	
67349	Natural & Herbal Remedies for Headaches (A-265)	978-1-58017-349-0	
67222	Sleep and Relaxation: A Natural and Herbal Approach (A-201)	978-1-58017-222-6	



#

- 100 Plants to Feed the Bees...32, 95
 100 Plants to Feed the Birds.....32
 100 Plants to Feed the Monarch... 32
 100 Skills You'll Need for the End of the World (as We Know It)107
 101 Arena Exercises for Horse & Rider94
 101 Designer One-Skein Wonders®78
 101 Dressage Exercises for Horse & Rider.....94
 101 Ground Training Exercises for Every Horse & Handler.....94
 101 Jumping Exercises for Horse & Rider94
 101 One-Dish Dinners.....56
 101 Perfect Chocolate Chip Cookies57
 101 Western Dressage Exercises for Horse & Rider.....94
 2-at-a-Time Socks.....76
 40 Fundamentals of English Riding94
 500 Treasured Country Recipes ...53

A

- Absolute Beginner's Guide to Keeping Backyard Chickens, An.....98
 Absolute Beginner's Guide to Raising Backyard Ducks, An.....98
 ADHD Alternatives.....37
 All Points Patchwork84
 American Axe115
 American Craft Beer Cookbook, The62
 Among Wild Horses.....92
 Ani Trime's Little Book of Affirmations43
 Animal Friends: Hello, Dogs!...22, 104
 Apple Cookbook, 3rd Edition, The50
 Aromatherapy Companion, The...41
 Around the Corner Crochet Borders81
 Art of Papercraft, The.....87
 Art of Tapestry Weaving, The.....83
 Art Sparks70, 86
 At Knit's End.....80
 Attracting Native Pollinators....47, 95
 Ayurveda Way, The.....42

B

- Baby's First Kind Words67
 Backpack Explorer 5-Book Set with Nature Collection Box.....64
 Backpack Explorer Stickers: Nature Adventure21
 Backpack Explorer: Beach Walk...64
 Backpack Explorer: Bird Watch...64
 Backpack Explorer: Bug Hunt64
 Backpack Explorer: Discovering Plants and Flowers22, 64
 Backpack Explorer: Discovering Trees64
Backpack Explorer: Night Walk ...14
 Backpack Explorer: On the Nature Trail64
 Backpack Explorer: Rock Hunt64
 Backyard Adventure72
 Backyard Bird-Lover's Guide, The45
 Backyard Cow, The.....101
 Backyard Foraging.....30, 45
 Backyard Goat, The101
 Backyard Homestead, The.....108
 Backyard Homestead Book of Building Projects, The...108, 114
 Backyard Homestead Book of Kitchen Know-How, The56, 108
 Backyard Homestead Guide to Growing Organic Food...23, 29, 108
 Backyard Homestead Guide to Raising Farm Animals, The101, 108
 Backyard Homestead Seasonal Planner, The108
 Backyard Lumberjack, The106
 Backyard Sheep, The.....101
 Baking Class.....48, 67
 Barnyard Games & Puzzles74
 Barnyard Sticker Book, The75
 Basic Butchering of Livestock & Game102
 Basic Welding for Farm and Ranch106
 Be Kind.....67
 Be Your Own House Contractor...114
 Beaded Jewelry: Knotting Techniques89
 Beaded Jewelry: Stringing Techniques89
 Beaded Jewelry: Wirework Techniques89
 Beading Answer Book, The89

- Bean-to-Bar Chocolate57
 Beef It Up!.....49
 Beer for All Seasons62
 Beer Geek Handbook, The.....62
 Beginner's Guide to Dehydrating Food, 2nd Edition, The54
 Beginner's Guide to Edible Herbs, The31
 Beginner's Guide to Growing Cannabis and Making Your Own Healing Remedies.....28, 31
 Beginner's Guide to Preserving Food at Home, The.....56
 Being with Trees42, 47
 Beyond the Square Crochet Motifs81
 Big Book of Cidermaking, The52, 60
 Big Book of Kombucha, The.....60
 Big Book of Preserving the Harvest, The56
 Bird Brainteasers45
 Bird Watching Answer Book, The45
 Birdfeeders, Shelters & Baths115
 Birthing Mama42
 Blacksmith's Craft, The.....106
 Blueberry Love51
 Body into Balance39
Boxful of Poetry, A6
 Braiding Manes and Tails.....93
 Bread Making: A Home Course...57
 Brew Chem 101.....62
 Build a Classic Timber-Framed House.....114
 Build Your Own Beekeeping Equipment.....95
 Build Your Own Farm Tools.....105
 Build Your Own Low-Cost Log Home114
 Build-a-Bowl50
 Building Raised Beds26
 Building Small Barns, Sheds & Shelters.....113
 Building Stone Walls115
 Building with Stone.....115
 Busy Little Hands: Art Play!66
 Busy Little Hands: Food Play!66
 Busy Little Hands: Math Play!66
 Busy Little Hands: Science Play!...66
 Butchering Beef.....103
 Butchering Chickens.....103
 Butchering Poultry, Rabbit, Lamb, Goat, and Pork.....103

C

- Cable Left, Cable Right.....80
 Candlemaker's Companion, The...89
 Cardboard Box Engineering.....70
 Carrots Love Tomatoes.....27
 Cast On, Bind Off.....80
 Cast-Iron Cooking.....48
 Cat Behavior Answer Book, 2nd Edition, The104
 Cattail Moonshine & Milkweed Medicine46
 Cattle Health Handbook, The...102
 Cherry Hill's Horse Care for Kids...74
 Chicken Coops99
 Chicken Encyclopedia, The.....98
 Chicken Games & Puzzles74
 Chicken Health Handbook, 2nd Edition, The98
 Chicken Wisdom Frame-Ups.....99
 ChopChop Family Cookbook.....48
 Chowderland51
 Christmas Crochet for Hearth, Home & Tree.....81
 Christopher Hobbs's Medicinal Mushrooms: The Essential Guide39
 Cider61
 Ciderhouse Cookbook.....52
 Circular Knitting Workshop.....77
 Classic Hewn-Log House, The...113
 Classic Zucchini Cookbook, The...51
 Clear the Clutter, Find Happiness117
 CloneBrews, 2nd Edition.....62
 Coffee Time61
 Cold-Climate Gardening31
 Collage Your Life.....87
Coloready Mushrooms 9, 89
 Color-Your-Own Greeting Cards...87
 Compact Cabins.....113
 Compact Farms.....105
 Compact Houses.....113
 Complete Compost Gardening Guide, The30
 Complete Guide to Restoring Your Soil, The.....30, 107
 Complete Guide to Saving Seeds, The34
 Complete Houseplant Survival Manual, The36
 Connect the Shapes Crochet Motifs.....81
 Cookie Classics Made Easy.....58
 Cookie Craft.....58

- Cookie Craft Christmas58
 Cooking & Baking Class Box Set48, 67
Cooking Class16, 48, 67
 Cooking Class Global Feast!...48, 67
 Cooking with Fire49
 Cooking with Whey.....54
 Cool, Cosmic Tattoo Stars and Planets22, 65
 Cordials from Your Kitchen61
 Country Life Coloring Book87
 Covering Ground34
 Creative Vegetable Gardener.....28
 Creatures of the Ocean Sticker Poster75
 Creatures of the Rainforest Sticker Poster75
 Creepy, Crawly Tattoo Bugs.....65
 Crochet Answer Book, 2nd Edition, The82
 Crochet One-Skein Wonders® ...79
 Crochet One-Skein Wonders® for Babies.....79
 Crochet Taxidermy.....80
 Crocheter's Skill-Building Workshop, The80
 Cured Meat, Smoked Fish & Pickled Eggs55
 Curious Nature Guide, The47
 Curry & Kimchi49
 Cute, Cuddly Tattoo Cats & Kittens22, 65, 104

D

- Dandelion Medicine, 2nd Edition...41
 Dave Miller's Homebrewing Guide62
 Deerproofing Your Yard & Garden35
 Design Your Own Crochet Projects80
 Designing Your Gardens and Landscapes35
 Design-Your-Garden Toolkit32
 Dishing Up® Maine59
 Dishing Up® Maryland59
 Dishing Up® Minnesota59
 Dishing Up® New Jersey.....59
 Dishing Up® New Mexico59
 Dishing Up® Virginia.....59
 Dishing Up® Washington59
 Dock Manual, The111
 Dog Behavior Answer Book, 2nd Edition, The104

- Donkey Companion, The100
 Don't Throw It, Grow It!.....30
 Donut Book, The57
 Drawn to Nature.....47
 Drink the Harvest.....60
 Drought-Resilient Farm, The.....107
E
 Earth Almanac47
 Easy-Gaited Horses93
 Edible Houseplants.....36
 Electric Fencing.....110
 Electric Fencing Handbook, The110
 Epic Tomatoes.....27
 Equine Fitness90
 Essential Guide to Calving.....102
 Essential Guide to Color Knitting Techniques, The77
 Essential Guide to Cultivating Mushrooms, The.....29
 Essential Oils Book, The.....41
 Every Which Way Crochet Borders81
 Everyday Gratitude43
 Everyday Gratitude Frame-Ups...43

F

- Fabric-by-Fabric One-Yard Wonders85
 Family Cow, The.....102
 Farm Anatomy46
 Farm Anatomy Sticker Book.....46
 Farm Fun Games & Puzzles.....75
 Farming with Native Beneficial Insects.....107
Farm-Raised Kids 5, 109
 Fat Kitchen, The.....56
 Fences for Pasture & Garden115
 Feng Shui Dos & Taboos117
Fermentation Oracle 10, 53
 Fermented Vegetables, 10th Anniversary Edition.....23, 52
 Field Guide to Fleece, The.....83
 Fiery Ferments52
 Finding Good Farmland110
 Fire Cider!.....38, 61
 Fish Grilled & Smoked48
 Fix, Freeze, Feast, 2nd Edition....54
 Fleece & Fiber Sourcebook, The83
 Flower Gardener's Bible, The.....33
 Fluttery, Friendly Tattoo Butterflies and Other Insects.....65

- Foaling Primer, The.....93
 Food Anatomy.....46, 58
 Food Faces.....67
 Foot Care Handbook40
 Freeze Fresh.....55
 Fresh Egg Cookbook, The48
 Fresh Flavors for the Slow Cooker50
 Fresh Honey Cookbook, The.....51
 From Vines to Wines, 5th Edition63
 Fruit Gardener's Bible, The.....29
 Furry, Friendly Tattoo Dogs & Puppies22, 65, 104

G

- Games on Horseback.....93
 Garden Flowers, 100 Postcards...33
 Garden Fresh, 100 Postcards33
 Garden Maker's Book of Wonder ...33
 Gardener's A-Z Guide to Growing Flowers from Seed to Bloom, The33
 Gardening with Biochar31
 Gardening with Emma27, 72
 Gardening with Less Water.....35
Garlic Companion 11, 60
 Getting Started with Beef & Dairy Cattle.....102
 Ghoulish Goodies.....58
 Girls' Home Spa Lab.....42, 71
 Give Thanks67
 Grasses32
 Grass-Fed Cattle.....102
 Gratitude Explorer Workbook, The...43
 Great Ball Game68
 Great Outdoors Games & Puzzles, The74
 Greywater, Green Landscape34, 111
 Groundbreaking Food Gardens ...28
 Grow a Little Fruit Tree.....29
 Grow More Food27
 Grow Your Handmade Business82
 Grow Your Own Herbal Remedies31, 39
 Grow Your Soil!30
 Growing & Using Herbs Successfully31
 Growing Christmas Trees.....110
 Growing Healthy Houseplants36
 Growing Under Cover28

- Growing Vegetables in Straw Bales26
 GrowVeg.....27
 Guerilla Furniture Design112
 Guess My Animal!69
 Guide to Canning, Freezing, Curing & Smoking Meat, Fish & Game, A ...55

H

- Hand Dyeing Yarn and Fleece83
 Hand Hewn.....114
 Handmade Marketplace, 2nd Edition, The.....82
 Hands-On Healing Remedies40
 Hardy Succulents32
 Harvest Baker, The57
 Hatching & Brooding Your Own Chicks98
 "Have-More" Plan, The105
 Healing Herbal Teas39, 60
 Healthy College Cookbook, The....58
Heart of the Hive..... 7, 95
 Hentopia98
 Herb Mixtures & Spicy Blends52
 Herbal Activities for Kids.....21, 89
 Herbal Antibiotics, 2nd Edition...37
 Herbal Antivirals, 2nd Edition.....37
 Herbal Goddess42
 Herbal Medic.....39
 Herbal Remedies for Sleep23
 Herbal Tea Gardens.....31
 Herbal Teas60
Herbs for Children's Health ...4, 38
 Herbs for Common Ailments38
 Herbs for Hepatitis C and the Liver...37
 Herbs for Long-Lasting Health38
 Herbs for Natural Beauty38
 Herbs for Stress & Anxiety.....38
 High-Vibe Feng Shui.....117
 Hive Management95
 Holistic Cancer Care37
 Home Cheese Making, 4th Edition54
 Home Creamery, The54
 Home Detox116
 Home Sausage Making, 4th Edition55
 Home Water Supply, The111
 Home Winemaker's Companion, The63
 Homebrewed Vinegar.....52
 Homebrewer's Garden, 2nd Edition, The.....29, 63

- Homebuilt Winery, The..... 63
 Homegrown Herbs 31
 Homegrown Honey Bees 95
 Homegrown Pantry..... 28
 Homegrown Pork.....101
 Homegrown Whole Grains..... 29
 HomeMade112
 Homemade Liqueurs and Infused Spirits 60
 Homemade Root Beer, Soda & Pop 60
 Homemade Yogurt & Kefir 54
 Homeowner's Complete Tree & Shrub Handbook, The..... 35
 Homeowner's Energy Handbook, The 111
 Horse Behavior Problem Solver, The 92
 Horse Breeds of North America 92
 Horse Breeds Poster Book, The 75
 Horse Conformation Handbook, The 93
 Horse Doctor Is In, The..... 93
 Horse Games & Puzzles..... 74
 Horse Health Care 91
 Horse Hoof Care 91
 Horse Nutrition Handbook, The 93
 Horse Play!..... 74
 Horse Training Problem Solver, The 92
 Horsekeeping on a Small Acreage 91
 Horse-Lover's Encyclopedia, 2nd Edition 90
 Hot Sauce!..... 49
 Hot Tubs, Saunas, & Steam Baths 111
 House Jungle..... 36
 How Carrots Won the Trojan War 29
 How to Be a Person..... 68
 How to Build Animal Housing..... 99
 How to Build Small Barns & Outbuildings 112
 How to Build Your Own Greenhouse 111
 How to Crochet 82
 How to Forage for Mushrooms without Dying 45
 How to Forage for Wild Foods without Dying 45, 61
 How to Forage for Wild Foods without Dying Journal 23, 45
 How to Knit..... 77
 How to Knit Socks That Fit..... 76
 How to Look at a Bird..... 23, 47
 How to Love the World 43
 How to Make a Quilt..... 84
 How to Make Chocolate Candies 57
 How to Make Curtains 85
 How to Make Ice Cream..... 55
 How to Make Maple Syrup 50
 How to Make Slipcovers 85
 How to Prune Trees & Shrubs 35
 How to Sleep Tight through the Night..... 68
 How to Speak Chicken..... 99
 How to Spin 82
 How to Think Like a Horse 91
 Howl like a Wolf!..... 69
 Human Body Learning Lab 70
 Humane Livestock Handling 100
- I**
- I Did It Myself!..... 66
 I Help at Home! 66
 I Want to Be a Farmer Activity Book..... 66
 I Want to Be a Teacher Activity Book..... 66
 I Want to Be a Vet Activity Book 66
 Illustrated Bestiary, The 44
 Illustrated Bestiary Collectible Box Set, The 44
 Illustrated Bestiary Oracle Cards, The 44
 Illustrated Bestiary Puzzle: Monarch Butterfly (750 pieces), The..... 44
 Illustrated Crystallary, The 44
 Illustrated Crystallary Oracle Cards, The 44
 Illustrated Crystallary Puzzle: Garden Quartz (750 pieces), The..... 44
 Illustrated Herbiary, The 44
 Illustrated Herbiary Collectible Box Set, The 44
 Illustrated Herbiary Oracle Cards, The 21
 Illustrated Herbiary Puzzle: California Poppy (750 pieces), The 44
 Increase, Decrease 80
 Incredible Octopus 23, 75
 Install Your Own Solar Panels..... 111
 Instant Pot Cheese..... 54
 Into the Nest 45
 Inventive Weaving on a Little Loom 83

J

- Journal Sparks 71, 86
 Joy in Every Moment..... 42
 Joy of Gardening 27
 Julia Rothman Collection, The..... 46
 Love Lives of Birds, The..... 45
 Love Your Amazing Self..... 68
 Low-Cost Pole Building Construction 113
- Julia Rothman's Farm Anatomy Activity Book..... 19, 69**
- Julia Rothman's Nature Anatomy Activity Book..... 69
 Julia Rothman's Ocean Anatomy Activity Book..... 23, 69
 Jumping for Kids..... 74
 Just in Case..... 117

K

- Keeping a Nature Journal, 3rd Edition 47
 Keeping Livestock Healthy 102
 Keeping the Harvest..... 56
 Kids' Building Workshop, The 71
 Kids Cook Dinner 49, 67
 Kid's Guide to Cats, A 73, 104
 Kid's Guide to Dogs, A 73, 104
 Kid's Guide to Keeping Chickens, A 75, 99
 Knife Skills 52
 Knit 2 Socks in 1..... 76
 Knit Christmas Stockings, 2nd Edition 77
 Knit One, Bead Too..... 80
 Knit Socks! 76
 Knit Your Socks on Straight..... 76
 Knitting Answer Book, 2nd Edition, The 77
 Knitting Modular Shawls, Wraps, and Stoles 77
 Knitting Pattern Writing Handbook 82
 Managing Pasture 107
 Maple Sugar 50
 Maple Syrup Cookbook, 3rd Edition 50
 Mason Jar Science 70
 Micro Activism 43
 Micro Living 112
 Microshelters 112
 Milk Soaps..... 88
 Milk-Based Soaps..... 88
 Milkweed Lands..... 36, 47
 Mindful Moves..... 68
 Mindful Way to a Good Night's Sleep, The 42
 Mini Meadows 33
 Miso, Tempeh, Natto & Other Tasty Ferments 52
 Mochi Magic 49

L

- Lace One-Skein Wonders® 79
 Lake Michigan Cottage Cookbook, The 58
 Landowner's Guide to Managing Your Woods, A 106
 Landscaping with Fruit..... 29
 Lavender Companion... 21, 33, 61, 89
 Leaning toward Light..... 36, 43
 Learn to Timber Frame 114
 Let It Rot!..... 30
 Let's All Keep Chickens!..... 98
 Let's Learn to Fish!..... 22, 69
Let's Move the Needle 8, 84

M

- Magical Science of Feelings..... 21
Maia Toll's Wild Wisdom Collection 12, 44
 Maia Toll's Wild Wisdom Companion 44
 Maia Toll's Wild Wisdom Tattoos 21, 44
 Maintaining Small- Farm Equipment 110
 Make Music!..... 70
 Make Your Own Board Game..... 86
 Make Your Own Money 71
 Make Your Own Pure Mineral Makeup..... 42
 Make-Ahead Sauce Solution, The 54
 Making & Using Vinegar..... 52
 Making Aromatherapy Creams & Lotions 41
 Making Hay 110
 Making Love Potions 40
 Making Natural Liquid Soaps..... 88
 Making Transparent Soap..... 88
 Making Wild Wines & Meads..... 63
 Making Your Small Farm Profitable 105
 Managing Manure 110
 Managing Pasture 107
 Maple Sugar 50
 Maple Syrup Cookbook, 3rd Edition 50
 Mason Jar Science 70
 Micro Activism 43
 Micro Living 112
 Microshelters 112
 Milk Soaps..... 88
 Milk-Based Soaps..... 88
 Milkweed Lands..... 36, 47
 Mindful Moves..... 68
 Mindful Way to a Good Night's Sleep, The 42
 Mini Meadows 33
 Miso, Tempeh, Natto & Other Tasty Ferments 52
 Mochi Magic 49

- Modular Home, The..... 114
 Monarch Butterflies..... 72
 Moon Cycle Cookbook, The... 39, 58
 My Chicken Family 99
 Mystical Stitches..... 85

N

- Natural First Aid Handbook, 2nd Edition, The..... 37
 Natural Hair Coloring 41
 Natural Soap Book, The 88
 Naturalist's Notebook, The 47
 Naturally Bug-Free 40, 117
 Naturally Clean Home, 3rd Edition, The 117
 Naturally Healthy Hair..... 41
 Nature Anatomy..... 46
 Nature Anatomy Notebook 46
 Nature Anatomy Sticker Book..... 46
 Nature Anatomy: Birds Puzzle (500 pieces)..... 46
 Nature Anatomy: Puzzle (500 pieces), The 46
 Nature Connection, The..... 73
 Nature Smarts Workbook, Ages 10-12 69
 Nature Smarts Workbook, Ages 4-6 69
 Nature Smarts Workbook, Ages 7-9 69
 Nature Smarts Workbook: All about Water (Ages 4-6)..... 22, 69
 Nature's Art Box..... 70
 Nettle Power 21, 41
 New England Clam Shack Cookbook, 2nd Edition, The 58
 Niki Jabbour's Veggie Garden Remix 28
 No Recipe? No Problem!..... 50
 No-Till Organic Vegetable Farm, The 29
- O**
- Ocean Anatomy 46
 Ocean Anatomy Sticker Book..... 46
 Ocean Anatomy: Puzzle, The (500 pieces)..... 46
 One-Skein Wonders® 78
 One-Skein Wonders® for Babies 79
 One-Woman Farm 109
 One-Yard Wonders 85
 Organic Body Care Recipes..... 40
 Organic Farming Manual, The... 107
 Organic Lawn Care Manual 35
 Our Fermented Lives..... 53

- Owling 45, 72

P

- Papermaker's Companion, The... 87
 Papermaking with Garden Plants & Common Weeds 87
 Path to Kindness, The..... 43
 Perennial Care Manual, The..... 32
 Perennial Gardener's Design Primer, The 32
 Perfectly Creamy Frozen Yogurt. 55
 Perfumes, Splashes & Colognes... 41
 Pesto Cookbook, The 49
 Pickled Pantry, The 56
 Picnic 49
 Pie Academy..... 57
 Plant Partners..... 26
 Plant Pets..... 21, 36
 Pony Play Games & Puzzles..... 74
 Poultry Breeds 99
 Prepping 101 116
 Preserving Answer Book, The..... 53
 Preserving Wild Foods..... 52
 Preventing Lyme & Other Tick-Borne Diseases 37
 Pruning Answer Book, The..... 35
 Pruning Made Easy 35
 Pumpkin Cookbook, 2nd Edition, The 50
 Pure Skin Care..... 40
 Pure Soapmaking 88
 Put 'em Up! 53
 Put On Your Owl Eyes 73

Q

- QueenSpotting..... 95
 Quilting Answer Book, The 84
 Quilting with a Modern Slant 84

R

- Rabbit Breeds 100
 Rabbit Housing 100
 Rabbit-Raising Problem Solver, The 100
 Rainbow Science 22
 Raptor!..... 72
 Raw Energy 53
 Raw Energy in a Glass 53
 Real Food for Dogs 104
 Recipes from the Herbalist's Kitchen..... 39, 53
 Recipes from the Root Cellar 56
 Recycled Crafts Box..... 70
 Reinventing the Chicken Coop 99

- Renovating Barns, Sheds & Outbuildings..... 112
 Rider's Fitness Program, The 90
 Riding for Kids..... 74
 Roaring, Rumbling Tattoo Dinosaurs 65
 Root Cellaring..... 56
 Rosemary Gladstar's Herbal Healing for Men 38
 Rosemary Gladstar's Herbal Recipes for Vibrant Health..... 38
 Rosemary Gladstar's Medicinal Herbs: A Beginner's Guide 31, 38
 Roses Love Garlic 27

S

- Sandalmaking Workshop, The ... 85
 Saving Seeds..... 34
 Saving Vegetable Seeds..... 34
 Say Cheese! 54, 70
 Sea Life Games & Puzzles 74
 Secret Lives of Backyard Bugs, The 47
 Secrets of Master Brewers, The... 63
 Secrets of Plant Propagation..... 34
 Secrets to Great Soil..... 30
 Seed Sowing and Saving 34
 Serving Up the Harvest 56
 Seven-Step Homestead 28
 Sewing Answer Book, The..... 84
 Sewing School® 71, 86
 Sewing School® 2..... 71, 86
 Sewing School® Box Set..... 71, 87
 Sewing School® Fashion Design 71, 86
 Sewing School® Quilts..... 71, 86
 Show Me a Story..... 70
 Showing Poultry..... 99
 Skoolie!..... 113
 Sky Gazing 72
 Slithering, Scaly Tattoo Snakes & Other Reptiles..... 65
 Small-Scale Livestock Farming... 101
 Smokehouse Handbook..... 55
 Soap Crafting..... 88
 Soapmaker's Companion, The..... 88
 Soaring, Singing Tattoo Birds..... 65
 Sock Yarn One-Skein Wonders® 78
 Soul of Gift Wrapping..... 23, 87
 Soul Support Book 2nd Edition, The 42
 Spice Apothecary..... 39

- Spinner's Book of Fleece , The..... 82
 Spinner's Book of Yarn Designs, The 83
 Spruce: A Step-by-Step Guide to Upholstery and Design..... 85
 Stablekeeping 91
 Starter Vegetable Gardens, 2nd Edition 26
 Starting & Running Your Own Horse Business, 2nd Edition... 90
 Starting & Running Your Own Small Farm Business..... 105
 Starting Seeds 34
 Stephanie Tourles's Essential Oils: A Beginner's Guide..... 40
 Stitch Camp 71, 84
 Storey's Basic Country Skills 109
 Storey's Curious Compendium of Practical and Obscure Skills... 109
 Storey's Guide to Keeping Honey Bees, 2nd Edition 96
 Storey's Guide to Raising Beef Cattle, 4th Edition 96
 Storey's Guide to Raising Chickens, 4th Edition 96
 Storey's Guide to Raising Dairy Goats, 5th Edition..... 96
 Storey's Guide to Raising Ducks, 2nd Edition..... 97
 Storey's Guide to Raising Horses, 3rd Edition 92, 96
 Storey's Guide to Raising Meat Goats, 2nd Edition..... 97
 Storey's Guide to Raising Miniature Livestock..... 97
 Storey's Guide to Raising Pigs, 4th Edition 96
 Storey's Guide to Raising Poultry, 4th Edition 97
 Storey's Guide to Raising Rabbits, 5th Edition 96
 Storey's Guide to Raising Sheep, 5th Edition 96
 Storey's Guide to Raising Turkeys, 3rd Edition 97
 Storey's Guide to Training Horses, 3rd Edition 92, 97
 Storey's Illustrated Breed Guide to Sheep, Goats, Cattle, and Pigs... 101
 Storey's Illustrated Guide to 96 Horse Breeds of North America..... 89
 Storey's Illustrated Guide to Poultry Breeds 99
 Strawberry Love..... 51
 Successful Small-Scale Farming... 105
 Super, Strong Tattoo Sharks..... 65

- Sustainable Homebrewing..... 63
 Sweet Remedies 39
- T**
- Tale of the Unwelcome Guest, The 68
 Tan Your Hide!.....102
 Taste of Honey, A 68
 Tasting Beer, 2nd Edition..... 62
 Tasting Cider..... 61
 Tasting Whiskey 63
 Temple Grandin's Guide to Working with Farm Animals100
 Thank You, Farm..... 73
 Thank You, Tree..... 73
 Things I Learned from Knitting . . . whether I wanted to or not..... 80
 Timber Frame Construction114
Tinkering Workshop..... 17
 Tiny Kitchen Cookbook, The..... 50
 Toe-Up 2-at-a-Time Socks..... 76
 Tomato Love 51
 Top-Down Crochet Sweaters..... 80
 Twist on Tofu 55
- U**
- Unclutter Your Mind117
 Under the Sea Poster Book..... 75
 Uniquely Felt..... 82
Universe in Verse2
 USDF Guide to Dressage, The..... 93
- V**
- Vegetable Garden Planner..... 27
 Vegetable Gardener's Bible, The 26
 Vegetable Gardener's Book of Building Projects, The..... 26
 Vegetable Gardener's Container Bible, The 26
 Vegetable Gardening Wisdom 28
 Veggie Gardener's Answer Book, The 27
 Vintage Beer 62
Vintage Postcard Collage Kit.... 13
- W**
- Wabi Sabi117
 Wake Up Grateful 43
 Water-Wise Home, The.....111
 We Garden Together!.....33, 72
 Weaving Explorer, The 83
 Week-by-Week Vegetable Gardener's Handbook..... 26
 What Can I Say?..... 68
- What Every Horse Should Know... 91
 What Goes on inside a Beaver Pond? 73
 What's Killing My Chickens?..... 98
 What's That Bird?..... 72
 Whole Farm Management106
 Wholistic Healing Guide to Cannabis, The..... 37
 Why We Quilt..... 84
 Wild Animals of North America... 75
 Wild for Horses 75
 Wild Winemaking..... 63
- Wild, Wonderful Tattoo Woodland Animals 20, 65**
- Wildcrafted Cocktail, The..... 61
 Wilderness Adventure Camp 73
 Wildlife Anatomy 46
 Wildlife Anatomy Sticker Book 21, 46
 Wildlife Ranger Action Guide..... 73
 Wildlife-Friendly Vegetable Gardener, The 28
 Winemaker's Answer Book, The...63
 Winner! Winner! Chicken Dinner...49
 Wonder of Small Things.....43
 Wonder Walls 85
 Wood Shop 70
 Woodland Homestead, The.....106
 Woodstove Cookery 53
 World of Coral Reefs, The 72
- World of Rot 18**
- Worms Eat My Garbage, 35th Anniversary Edition..... 30, 109
- Y**
- Yarnitecture 83
 Year-Round Vegetable Gardener, The 28
 You & Me Are So Nice Together42
 Your Goats102
 Your Idea Starts Here..... 86
 Zen Mind, Zen Horse..... 90
 Zucchini Love 51

A

- Abkin, Unmi..... 49
 Abrams, Marion 70, 87
 Adolph, Jonathan 70
 Ahrens, Lindsay 54
 Ajmera, Ananta Ripa..... 42
 Allen, Beatrice Boggs..... 21, 36
 Allen, Laura 34, 111
 Allen, Linda L. 94
 Alworth, Jeff 63
 Anderson, Alison..... 50
 Anderson, Heather 42
 Anderson, Sarah 83
 Anderson, Steven..... 50
 Andrews, Corinne 42
 Appelhof, Mary 30, 109
 Armitage, Dan..... 22, 69
 Aubrey, Sarah Beth..... 105

B

- Bailey, Elisabeth..... 54
 Bainbridge, David A. 35
 Baldwin, Edward A. 115
 Ballou, Jec Aristotle..... 90, 94
 Battaglia, Evelyn 55
 Becker, Kaori 49
 Beemer, Will 114
 Belanger, Jerry 96
 Bender, Richard W. 63
 Bennett, Bob 96, 100
 Bennett, Steve 93
 Bennett-Talbot, Betty 93
 Bestor, Leslie Ann 77, 80
 Biggs, Emma 27, 72
 Biggs, Steven 27, 72
 Billis, Stacie..... 49
 Blum, Andrea 52
 Blum, Nicole 52, 71, 84
 Boggs, Belle 21, 36
 Bonney, Richard E. 95, 96
 Booth, Nancy M. 41
 Bowers, Sharon..... 58
 Boyles, Stephanie 94
 Bradley, Fern Marshall..... 26, 34
 Braren, Ken 112
 Bredesen, Sara Thomson 96
 Brown, Amanda..... 85
 Brown, Kathleen 60
 Brown, Molly Meehan 21, 89
 Bryant, Jennifer O. 93
 Bryson, Lew..... 63
 Bubel, Mike 56
 Bubel, Nancy 56
 Buhner, Stephen Harrod..... 37
 Burch, Monte..... 112, 113
 Burdick, Joseph..... 111

- Burdick, Philip..... 111
 Burns, Max..... 111
 Burris, Judy 46
 Butler, Carol A. 92
 Byczynski, Lynn..... 27

C

- Cabrera, Chanchal 37
 Caldwell, Gianacis 54
 Callahan, Gail 83
 Campbell, Stu..... 30, 111
 Cantley, Ashley..... 117
 Cardillo, Rob 33
 Cardoza, Nicole 68
 Carlsen, Spike..... 108, 115
 Carr, Jonathan..... 52
 Carroll, Ricki 54, 70
 Carroll, Sarah..... 54, 70
 Carson, Mary Kay 73
 Caughey, Melissa..... 75, 99
 Cavitch, Susan Miller 88

- Chace, Daniella..... 116
 Chadwick, Janet 56
 Chapin, Kari 82
 Chase, Nan K. 60
 Chattman, Lauren 57
 Chesman, Andrea 56, 108
 Chesney, Alexis 37
 Chioffi, Nancy 56
 Choi, Betty 70
 Choiniere, Joseph..... 72
 Clare, Bevin..... 39
 Cobb, Tanya Denckla 23, 29, 108
 Coffman, Sam 39
 Cohen, Stephanie 32
 Colleen K. Dodt 42
 Collins, Bill..... 52, 57
 Combs, Dawn..... 39
 Cook, Deanna F. 16, 48, 49, 67, 74
 Cooper, Jane..... 53
 Cornog, Phoebe..... 85
 Corry, Rachel..... 85
 Costenbader, Carol W. 56
 Cox, Jeff 31, 63
 Craig, Katie 74
 Cresswell, Stephen 60

- Crews, James 6, 43
 Crowe, Alison 63
 Crow-Miller, Britt 18
 Crum, Hannah..... 60
 Curtis, Alice 76

D

- Daily, Jen 21
 Damerow, Gail 96, 98, 101, 108, 115

- Danforth, Adam..... 103
 Daniels, Jesse Terrance 86
 Dauksas, Linda..... 66
 Dawson, Patrick..... 62
 Delaney, Sara 80, 82
 Dennis, Dianna Robin 90, 94
 DeWitt, Dave 59
 Diedricksen, Derek "Deek" 112
 Dodt, Colleen K. 41, 42
 Dojny, Brooke..... 51, 58, 59
 Donnelly, Meredith Magee 66
 Dornan-Smith, Annie..... 36
 Downey, Shannon 8, 84
 Drowns, Glenn 97, 99
 Druchunas, Donna..... 76
 Dunham, Jessica 21, 33, 61, 89
 Durant, Judith 78, 79, 80
 Durston, Diane..... 117
 Dutton, Judith..... 92

E

- Eastman Jr., Wilbur F..... 55
 Eckert, Carolyn..... 86
 Eckman, Edie 79, 81, 82
 Eddy, Carson 89
 Edwards, Victoria H. 41
 Ekarius, Carol 83, 96, 99, 101
 Ellis, Barbara W 27, 34, 35
 Engler, Nick..... 112
 Environmental Educators of Mass Audubon, The..... 22, 69
 Erickson, Laura..... 32, 45
 Evans-Hylton, Patrick..... 59

F

- Failor, Catherine 88
 Faiola, Anne-Marie..... 88
 Farr, Sarah 39, 60
 Farrell-Kingsley, Kathy..... 54
 Fisher, Dennis 29, 63
 Fisher, Joe 29, 63
 Formicola, Jessica 49
 Franklin, Devin 73
 Fries, Hannah 42, 47
 Fryer, Janice..... 58

G

- Galvery, William..... 106
 Gervais, Michelle 32
 Gianino, Andrew 114
 Gilleland, Diane 84
 Giller, Megan..... 57
 Gladstar, Rosemary.... 4, 31, 38, 61
 Golding, Claire Mowbray..... 72
 Good, Phyllis..... 50
 Gop, Becky Cushing 73

- Gough, Robert 34
 Gover, Tzivia 42, 68
 Grandin, Temple 100
 Graubart, Cynthia 51
 Graves, Kristin..... 11, 60
 Gregory, Aaron John 65
 Griffith, Roger..... 112
 Grindrod, Frank..... 73
 Groves, Maria Noël 23, 31, 39
 Guest, DeNeice C. 60
 Gulling, Rich 63

H

- Haas, Jessie 90
 Haedrich, Ken..... 50, 57
 Halloran, Ed 63
 Halm, Brad 27
 Hamilton, Allan J. 90
 Hansen, Ann Larkin 107, 108, 110
 Hansen, Steve 106
 Hard, Roger..... 114
 Harrison, Kathy..... 116, 117

- Hart, Rhonda Massingham..... 35
 Hartung, Tammi..... 28, 31, 46
 Haynes, Norma Jean..... 70
 Haynes, N. Bruce 102
 Heldmann, Carl..... 114
 Herd, Tim 50
 Hiebert, Helen..... 87
 Hill, Cherry..... 74, 91, 94
 Hill, Lewis..... 31, 33, 35, 110
 Hill, Nancy 33
 Hirschi, Jane 33, 72
 Hobbie, Ann 72
 Hobbs, Christopher 39
 Hobson, Phyllis..... 102
 Holderread, Dave 97
 Holl, John..... 59, 62
 Holman, Will 112
 Hoskins, Patricia..... 85
 Hovanec, Helene..... 61, 74, 75
 Howard, Joy..... 51
 Hughes, Steve 63
 Hyman, Frank 45, 98

I

- Inouye, Megumi Lorna..... 23, 87

J

- Jabbour, Niki..... 28
 Jackson, Ty Allan..... 71
 Jacobs, Betty E. M. 31
 Jahiel, Jessica 92
 James, Erin..... 61
 Janson, Lee W. 62

- Janssen, Mary Beth 41
 Jarchow, Deborah 83
 Jenkins, Ryan 17
 Jirsa, Amy..... 42
 Johnson, Christi..... 85
 Jones-Quartey, Ofosu..... 68
 Juris, Paul M. 90

K

- Kearney, Hilary 7, 95
 Keegan, Caitlin..... 87
 Kelaidis, Gwen Moore 32
 Kelley, Brent..... 93
 Kempton, Beth 3
 Khalilallah, Saniyyah..... 66
 Klober, Kelly 96
 Knauer, Thomas 84
 Koffman, Deb 42
 Kopecky, Mark..... 110
 Kostovick, Allison Vallin..... 33
 Kujawski, Jennifer 26
 Kujawski, Ron..... 26
 Kulla, Katie..... 5, 109

L

- LaGory, Alex 60
 Langrish, Bob..... 75
 Larson, Margaret..... 70
 Laubach, Christyna M. 72
 Laubach, René 72
 Lay, Hilary Emerson 70, 86
 Leapman, Melissa 77
 Lee-Mäder, Eric 36, 47
 LeHoullier, Craig..... 26, 27
 Leslie, Clare Walker..... 23, 47, 73
 Levin, Amelia..... 58
 Levin, Jake 55
 Lewis, Charni..... 93
 Lisle, Andria..... 71, 86
 Littlefield, Cindy A..... 74
 Lizotte, Mike 33
 Loftus, Devon..... 39, 58
 Lucero, Claudia..... 54
 Lynch, Kelly 13

M

- Macher, Ron 105
 Macunovich, Janet..... 35
 Madigan, Carleen..... 108
 Mahle, Annie..... 50
 Mahnken, Jan 45
 Makela, Casey..... 88
 Manikowski, John..... 48
 Marcin, Marietta Marshall 31
 Marcoux, Paula..... 49
 Maria, Donna 41

Marlena Agency, Artists of.....	42	Oppenheimer, Betty.....	89
Marrone, Teresa.....	59	Oster, Maggie.....	52
Mars, Brigitte.....	21, 37, 41	O'Sullivan, Penelope.....	35
Marshall, Roger.....	111		
Martin, Byron E.....	36	P	
Martin, Deborah L.....	30	Pagán, Maya.....	42, 71
Martin, Laura C.....	70	Palanjian, Amy.....	66
Martin, Laurelynn G.....	36	Pan, Hsinping.....	67
Masterton, Laurey.....	51	Pangman, Judy.....	99
May, Rachel.....	84	Patry, Karen.....	100
Mays, Daniel.....	29	Pearl-McPhee, Stephanie.....	80
McCarthy, Betsy Lee.....	76	Pelzel, Raquel.....	52
McCrate, Colin.....	27	Peterson, Deborah.....	30
McCully, John J.....	90	Peterson, Valerie.....	58
McDonald, Mary Ashby.....	90	Philbrick, Frank.....	106
McElroy, Kevin.....	99	Philbrick, Stephen.....	106
McFarland, Cynthia.....	93	Pisano, Tony.....	95
McGrath, Kristina.....	82	Pitzer, Sara.....	29
McLeod, Brett.....	106, 115	Pleasant, Barbara.....	26, 28, 30, 36
McNeil, Hollie H.....	94	Plumley, Amie Petronis.....	71, 86
McRaven, Charles.....	106, 113, 115	Poe, Rhonda Hart.....	93
Mead, Gretchen.....	56	Pomeranz, Lynne.....	92
Merrell, Patrick.....	45, 75	Popova, Maria.....	2
Mettler Jr., John J.....	102	Powell, Eileen.....	33
Meyer, Karl.....	75	Prima, Roxy.....	85
Mezoff, Rebecca.....	83	Proulx, Annie.....	61
Miessler, Diane.....	30		
Miller, Dave.....	62	R	
Mitchell, Syne.....	83	Radcliffe, Margaret.....	77
Monterroso, Dalia.....	98	Radomski, Jenna.....	39, 58
Moore, Arden.....	73, 104	Ralph, Ann.....	29
Moore-Gough, Cheryl.....	34	Ralston, Nancy C.....	51
Moreno, Jillian.....	83	Raymond, Dick.....	27
Morgan-Oakes, Melissa.....	76	Read, Marie.....	45
Morris, Karen.....	89	Reavis, Charles G.....	55
Morrison, Alethea.....	95	Reich, Lee A.....	29
Mosher, Randy.....	62	Richards, Wayne.....	47
Mowinski, Melanie.....	87	Richmond, Susan Edwards.....	66
		Riotte, Louise.....	27
N		Robertson, Barbara.....	71
Narins, Rachael.....	48	Robertson, J. Craig.....	71
Nelson, Kristi.....	43	Robinson, Carolyn.....	105
Network for Grateful Living, A.....	43	Robinson, Ed.....	105
Neuburger, Emily K.....	71, 86	Robson, Deborah.....	82, 83
Neville, Kati.....	54	Roehrig, Artemis.....	22, 65
Newman, Catherine.....	68, 71, 84	Rogers, Marc.....	34
Newman, Lesléa.....	68	Romm, Aviva.....	37
Nichols, Lew.....	61	Romm, Tracy.....	37
Nickerson, Brittany Wood.....	39, 53	Rothman, Julia.....	19, 21, 23, 46,
Nimetz, Alexandra.....	58		58, 69
		Rowan, Gerald.....	113
O		Roxas, A.K.....	9
O'Hara, Kate.....	21, 44	Ruechel, Julius.....	102
Ohrenstein, Dora.....	80	Rupp, Rebecca.....	29
Olszewski, Joanne.....	30, 109	Russell, Stephen.....	29
Ondra, Nancy J.....	32		

S		Thacher, Meg.....	22, 65, 72
Sampson, Sally.....	48	Thomas, Heather Smith.....	93, 96, 97, 102
Sanford, Malcolm T.....	96	Thompson, Jennifer Trainer.....	48, 49
Sayer, Maggie.....	97	Thomsen, Amanda.....	72
Scalise, Brandi.....	58	Thomson, Jess.....	59
Scheckel, Paul.....	111	Toll, Maia.....	12, 21, 44
Schloss, Andrew.....	60	Tourles, Stephanie L.....	40, 53, 117
Schmidt, Crystal.....	55	Trang, Corinne.....	55
Schrider, Don.....	97	Trawin, David.....	9, 89
Schroeder, Roger.....	114	Trimble, Kelly Smith.....	28
Sellnow, Les.....	92	Trime, Ani.....	43
Severson, Mike.....	106	Tukey, Paul.....	35
Shahin, Christine.....	41	Turner, Carole B.....	34
Sheir, Rebecca.....	68		
Shockey, Christopher.....	52, 60	V	
Shockey, Kirsten K.....	23, 52	Van Loon, Dirk.....	102
Shulman, Naomi.....	67	Vanheems, Benedict.....	27
Siegel-Maier, Karyn.....	117	Vargas, Pattie.....	61
Simmance, Alison Sky.....	75	Vesci, Terry Barlin.....	21, 33, 61, 89
Simmance, Fiona Ocean.....	75	Vinton, Sherri Brooks.....	53
Simmons, Paula.....	96	Vivian, John.....	115
Sizemore, Nicki.....	50	Volk, Josh.....	105
Skinner, Julia.....	10, 53		
Smallin, Donna.....	117	W	
Smith, Beth.....	82	Wald, Christina.....	75
Smith, Charles W. G.....	31	Walliser, Jessica.....	26
Smith, Edward C.....	26	Walworth, Sarah.....	82
Smith, Nicole.....	82	Ward, Lesley.....	74
Snodgrass, Lucie L.....	59	Weaver, Sue.....	97, 100, 101
Sobon, Jack A.....	114	Webb, Leah M.....	28
Solomon, Karen.....	55	Weingarten, Matthew.....	52
Spagna, Ana Maria.....	107	Weston, Nicole.....	55
Spaziani, Gene.....	63	Wheelwright, Nathaniel T.....	47
Spencer, Erin.....	23, 72, 75	White, Christine.....	82
Stanley, Jason.....	58	White, Jeanne.....	66
Steege, Gwen W.....	57, 77	White, Patrick.....	110
Steinberg, Sally Levitt.....	57	Williams, Omkari L.....	43
Stell, Elizabeth P.....	30	Williams, Ted.....	47
Stephenson, Garry.....	106	Wilson, Mark.....	45, 72
Stone, Lynn M.....	100	Wiseman, Ann Sayre.....	70
Storey, John.....	109	Woginrich, Jenna.....	98, 109
Storey, Martha.....	53, 109	Wolfe, Ralph.....	113
Stovel, DeeDee.....	49, 50	Wolpe, Matthew.....	99
Strickler, Dale.....	30, 107	Wong, Angi Ma.....	117
Stuckey, Maggie.....	50, 60	Woodier, Olwen.....	49, 50
Sutherland, Will.....	113	Worth, Melyni.....	93
Sweet, Tammi.....	28, 31, 37		
Szamatulski, Mark.....	62	XYZ	
Szamatulski, Tess.....	62	Xerces Society, The.....	32, 47, 95, 107
		Yaker, Rebecca.....	85
T		Yale, Kathleen.....	69
Talbert, Barbara Weiland.....	84	Zachos, Ellen.....	23, 30, 36, 45, 61
Tally, Safiyah.....	76	Ziegler, Lee.....	93
Taylor, Roger.....	49		
Taylor, Tess.....	36, 43		

GIFT FIELD SALES REPRESENTATIVES AND SHOWROOMS

AL, AR, FL, GA, IA, KS, LA, ML, MN, MO, MS, NC, ND, SC, SD, TN, TX, WI
Anne McGilvray & Co.

Showrooms:
 Americasmart Showroom #1718
 40 John Portman Boulevard, NW
 Atlanta, GA 30303
 atlanta@annemcgilvray.com

2332 Valdina Street
 Dallas, TX 75207-6108
 Call: 800-527-1462 Ext. 1
 dallas@annemcgilvray.com

10301 Bren Road West
 Orange Gallery Rooms 339,
 378 and 379
 Minnetonka, MN 55343
 Call: 952-932-7153
 minneapolis@annemcgilvray.com

CO, MT, NM, WY,
National Parks
B. Hawley Sales

6627 Apache Court
 Longmont, CO 80503
 Cell: 303-819-3067
 Office: 303-834-8961
 bon@bhawleysales.com

AK, ID, OR, WA
Fine Lines Company

Showrooms:
 Seattle Mart
 200 SW Michigan Street
 Suite #213
 Seattle, WA 98106
 info@finelines.com

CT, DC, DE, MD, NJ, PA, VA,
 MA, ME, NH, RI, VT,
**Long Island, Rockland,
 Westchester, Putnam
 Counties**
Harper Group

Showrooms:
 345 North Street
 Saco, ME 04072
 Call: 888-644-1704
 Fax: 212-868-1704
 sales@harpergroup.com

Kilburn Mill
 127 Rodney French Boulevard
 Suite S2-85
 New Bedford, MA 02744

Upstate NY
Helen Kaminski & Co
 Call / Fax: 845-626-0001
 hkaminskiandco@gmail.com

Manhattan, Brooklyn, Queens,
 Bronx, and Staten Island
Total Communications
 Call: 917-846-2628
 Fax: 646-651-4565
 barbaratoback@gmail.com

IL
BGN Sales Group, LLC
 Call: 888-276-8048
 info@bgnsales.com

IN, KY, OH, WV
Son & Associates
 Call: 800-800-5312
 Fax: 740-881-1988
 michelle@sonassociates.com

CA, NV, AZ, HI, UT
Stephen Young

Showrooms:
 1933 S. Broadway, Suite 830
 Los Angeles, CA 90007

World Market Center
 457 S. Grand Central Parkway
 Suite C-1112
 Las Vegas, NV 89016
 Call: 800-282-5863
 Fax: 888-748-5895
 info@stephenyoung.net

Ordering Information



Storey Publishing

210 MASS MoCA Way, North Adams, MA 01247
 www.hachettebookgroup.com/imprint/storey

TO PLACE AN ORDER:

New Accounts:

We'd love to work with you!
 For information regarding discounts
 to non-bookstore retailers,
 wholesalers, mail-catalogs,
 corporations, organizations and
 more, please contact us as follows:

Call us: 800-827-8673

Email us:
 special.markets@hbgusa.com

Existing Accounts:

To place an order, please contact
 your sales rep or you can email
 your order directly to:
orders@hbgusa.com
 or fax it to 800-865-3429

Please be sure to include your
 account # and contact info.

**IF YOU HAVE
 OTHER QUESTIONS:**

Customer Service:
 customer.service@hbgusa.com
 or call 1-800-759-0190

To report damages, overages,
 or receiving an incorrect item:
claims@hbgusa.com

Our Mission

*To serve our customers by publishing
 practical information that encourages
 personal independence in harmony
 with the environment.*



Storey Publishing

www.hachettebookgroup.com/imprint/storey